



250/350 Ton Elevator / Spider Operation Manual

CONFIDENTIALITY STATEMENT

This document contains confidential information. All rights including copyright, confidential information, trade secrets and design rights are owned by Texas International Oil Field Tools, LTD (TIOT, Texas International, and Texas International Oilfield Tools). No use or disclosure is to be made without prior written permission of Texas International Oilfield Tools, LTD.

Revision History

Rev	Date	Reason
A	11/11/14	Issued for Use
B	4/10/15	Added warnings
C		

Description of Change

Rev	Change
A	Combined 250 and 350 Elevator Manuals
B	Added warning regarding door pin on page 4 and warning regarding locking mechanism page 7

TABLE OF CONTENTS

GENERAL	4
CONVENTIONS	5
SAFETY	5
SPECIFICATIONS	5
INSTALLATION	6
PNEUMATIC OPERATION	6
MANUAL OPERATION	7
LOCKING HANDLE OPTION	8
MAINTENANCE	9
WEAR DATA	12
CRITICAL AREA MAPS	13
TROUBLESHOOTING	14
STORAGE AND TRANSPORTATION	14
COMPONENTS	15
ANCILLARY COMPONENT LIST	20

GENERAL



Figure 1: Elevator and Spider Configuration

The purpose of the 250 and 350 ton elevator/spider (E/S) is to grip and lift API sized pipe vertically. It shall be configured either as an elevator hoisted by industry standard links or as a spider mounted on the rig floor or rotary table. As a spider, the unit is dressed with a top guide to aid centering the tubular string and adapter plate used to secure the tool onto a rotary table. As an elevator, the unit uses a bell guide, bottom and door guide.

Interchangeable slip assemblies and inserts allow each elevator/spider to handle different size API pipe. The 250 ton handles 2-3/8" to 7-5/8". The 350 ton accommodates 4-1/2" to 13-5/8". Inserts enable pipe handling with an OD up to 1" smaller than nominal slip size.

When the slip assembly is in the open position, the pipe and couplings may move freely vertically through the elevator. When slips are in the set position, the pipe is held without inflicting damage. A locking mechanism prevents accidental actuation of the slips. The tool can be either manual or pneumatically operated.



Insert hinge pin before applying load. If door is open or not secured by pin, the elevator/spider will be damaged under load

CONVENTIONS



IMPORTANT SYMBOL IDENTIFICATION	
	WARNING to Operators / Users
	CAUTION to Operators / Users
	NOTIFICATION to Operators / Users

Table 1

SAFETY

Texas International's equipment is used and installed in controlled rig environments involving hazardous operations and situations.

All personnel performing installation, operations, repair or maintenance on this elevator/spider must have knowledge of rig procedure. All crew in the vicinity of operations should be trained on rig safety and tool operation. Crew must be instructed for safe use of this elevator / spider.

SPECIFICATIONS

Capacity Short Tons	Pipe Range Inches	Operating Pressure* PSI
250	2 3/8 To 7-5/8	85 - 125
350	4-1/2 To 13-5/8	85 - 125

**If pneumatic*

Table 2

INSTALLATION



- Ensure the elevator's body, door and bell guide are tightened and correspond to the tubular size
- Ensure the spider's top guard plate and top guides are properly fastened and correspond to the tubular size
- Verify the inserts correspond to both the slip and tubular size. Make sure they are secured by the insert retaining plate

Elevator

- Unfasten link block bolts
- Hang elevator on the links
- Fasten link block nuts

Spider

- Place adapter plate on the rotary table
- Secure by placing the tool on the opening of the plate

Pneumatic Elevator / Spider

- Connect the air supply to the quick connect coupling at the rear of the tool
- Make sure the air supply range is within 85-125 PSI

PNEUMATIC OPERATION

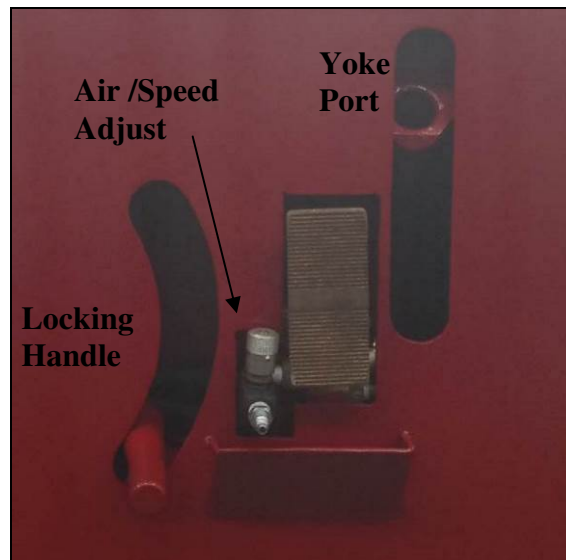

Figure 2: 350 Ton E/S

Releasing the Pipe

- Move the locking handle to the bottom position to raise slips
- Press the top of the pedal to release the slip's grip on the pipe

Gripping the Pipe

- Move the lock handle to the upper position to lower slips
- Depress the pedal at the bottom to bring the slips down to grip the pipe



The following can create an unsafe working condition:

- 1) operating the E/S without the locking mechanism
- 2) using an improperly maintained locking mechanism, or
- 3) not locking the E/S correctly

MANUAL OPERATION

Releasing the Pipe

- Set the lock handle to the bottom position to raise the slips
- Insert the lever into the yoke port (on left on 250 ton and right on 350 ton)
- Using the lever, bring the yoke to the down position until it clicks in place indicating the slips are locked



The slips move up, rest and lock on the upper ID of the cone. The locking mechanism prevents unintended setting of the slips

Gripping the Pipe

- Pull out the lever from the yoke port
- Move the lock handle into the upper position to lower the slips
- The slips fall inside the tool's cone and grip the pipe



The following can create an unsafe working condition:

- 1) operating the E/S without the locking mechanism
- 2) using an improperly maintained locking mechanism, or
- 3) not locking the E/S correctly

LOCKING HANDLE OPTION

Texas International offers a removable lock handle option. See Figure 3.



Figure 3: 250 Ton E/S - back plate removed

The long handle (p/n T28512-2) is for pneumatic and the short handle (p/n T28512-1 - shown in Figure 3 at its stored position) is for manual operated. The handle is threaded with a lock washer and a set screw to keep it securely in place.

MAINTENANCE

Lubrication

Recommend the use of Extreme Pressure (EP) Grease as indicated below:

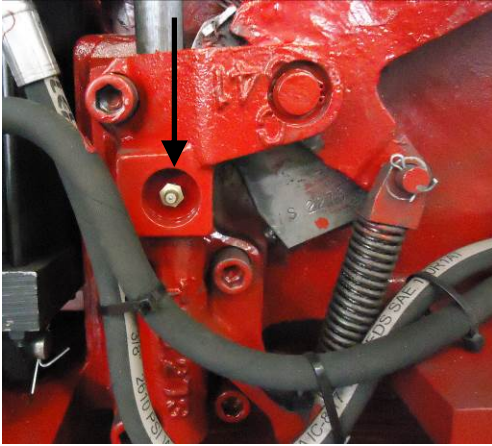

Locking mechanism: grease fitting (as seen on manual E/S) & spring

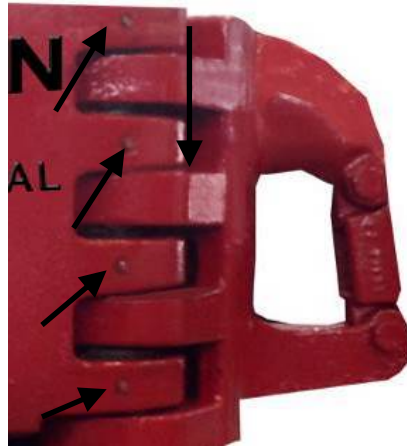

Hinge pin: grease fittings & ear contact surface (350 ton shown)



Yoke eye contact surface

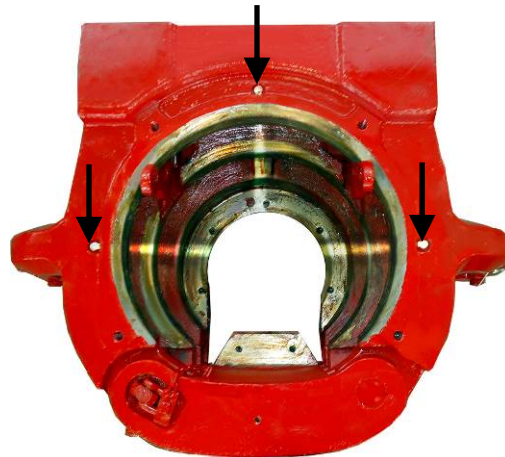

On 350 ton, fill grease dispensers to lubricate the inside bore. The lighted areas indicate slip contact

Figure 4: Key Lubrication Points



- Make sure the air supply (if pneumatic) is disconnected before any maintenance is performed
- Use light machine oil on the inserts and its slot - do not apply grease or pipe dope as it could result in slip damage
- Lubricate all moving parts

Changing Slips

- Raise or release the slips by moving the locking handle in the bottom position
- Suspend the slips using a line and pull safety cotter pins (2) and retainer pins (2) from the yoke
- Lift slip assembly from the tool's cone
- Replace with the properly sized set of slips – verify inserts are correct
- Suspend replacement slips from a line
- Ensure the yoke eyes are in the up position
- Insert slips into the cone and reinstall retainer pins and safety cotter pins



Figure 5: Slip Change – removing retainer pin

Changing Inserts

- Remove slips per instructions above and place on a flat surface
- Unfasten and pull out the insert retaining screws
- Pull the inserts out of the slip slots - using a small pry bar and hammer, if needed



Make sure the insert slots are not damaged during the removal

- Remove all debris from the slots and add a thin layer of light machine oil
- Place new inserts into the slots with the teeth pointing up - make sure they are all the same type and size
- Fasten insert retaining screws

Changing Bottom and Door Guide

- Remove the slip assembly as per instructions above
- Remove the door pin and open door
- Unfasten door guide screws and washers
- Select guide size range to accommodate the tubular used
- Fasten in place with screws and washers



Door guide installation

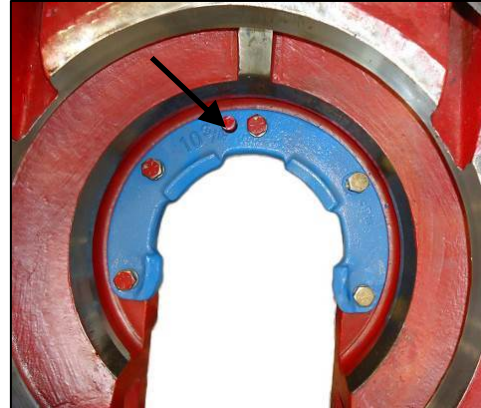

Body guide installation - use locating pin to set in place

Figure 6: Bottom Guides



Make sure guides are the same size range and match the tubular size. Failure may result in severe tool damage

Assessment and PM schedule

The end user is responsible to establish an inspection schedule and criteria subject to tool usage, wear and environmental conditions. TIOT recommends daily, semiannual and annual inspections as follows:

- Daily / Shift / Job Start Up
 1. Assess lubrication and replenish as needed
 2. Check fasteners - make sure there are no loose or missing components
 3. Verify ancillary equipment matches tubular size
 4. Inspect the contact surface of the ears. If surfaces are flattened or metal is rolled, the elevator should be pulled from operation for Annual PM
 5. Actuate slips and locking mechanism several times to check performance

Maintenance continued

6. On pneumatic, visually check hoses for wear and tear- replace if leaks are found
 7. Inspect inserts and replace as needed
 8. Check slip retaining bottom sections (toes) for twisting and cracks
- Semiannual
 1. Verify lubrication - make sure all grease fittings are in place
 2. Inspect slip grip - review witness marks on the mandrel/pipe made by inserts. Apply paint on the mandrel/pipe and paper, if needed
 3. Remove coating and debris from critical areas
 4. Complete Magnetic Particle Inspection (MPI) - repair as needed
 - Annual
 1. Performance Load Test Elevator according to API RP 8B
 2. Perform MPI twenty four (24) hours after load test according to ASTM E709 and use API 8C as criteria
 3. Repair cast as needed – recommend repairs be done by TIOT



Proof of load test and MPI are required after remanufacture or a major weld repair in a critical area

WEAR DATA

Model	250 Ton	350 Ton
Total Clearance (in inches)		
Hinge Pin "A"	0.036	0.036
Min. Dia.	1.860	2.485
Ears (in inches)		
Radius "R"	2.00	2.50
"E"	15.25	20.50
"D" Min.	4.50	5.50

Table 3

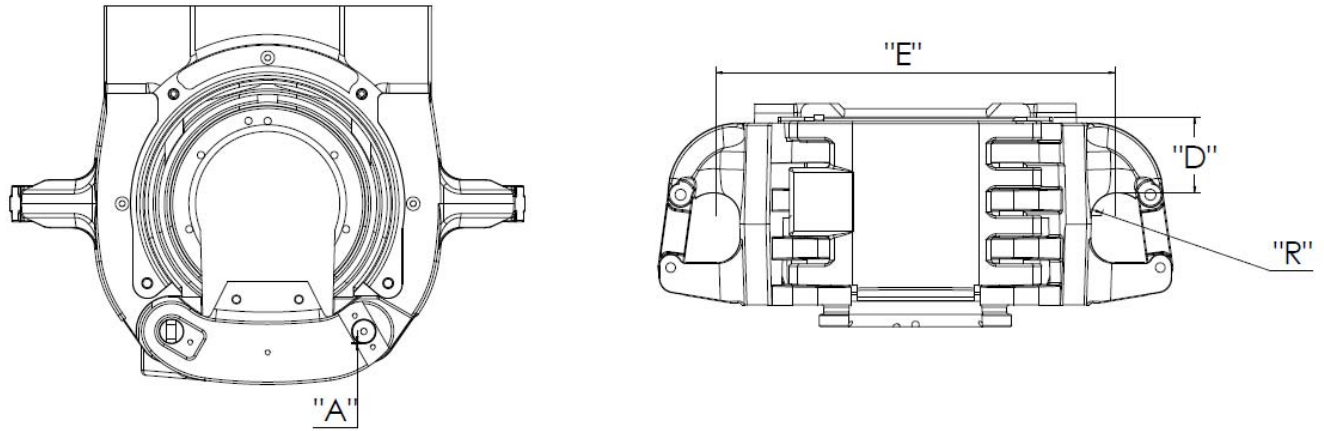

Figure 7

CRITICAL AREA MAPS

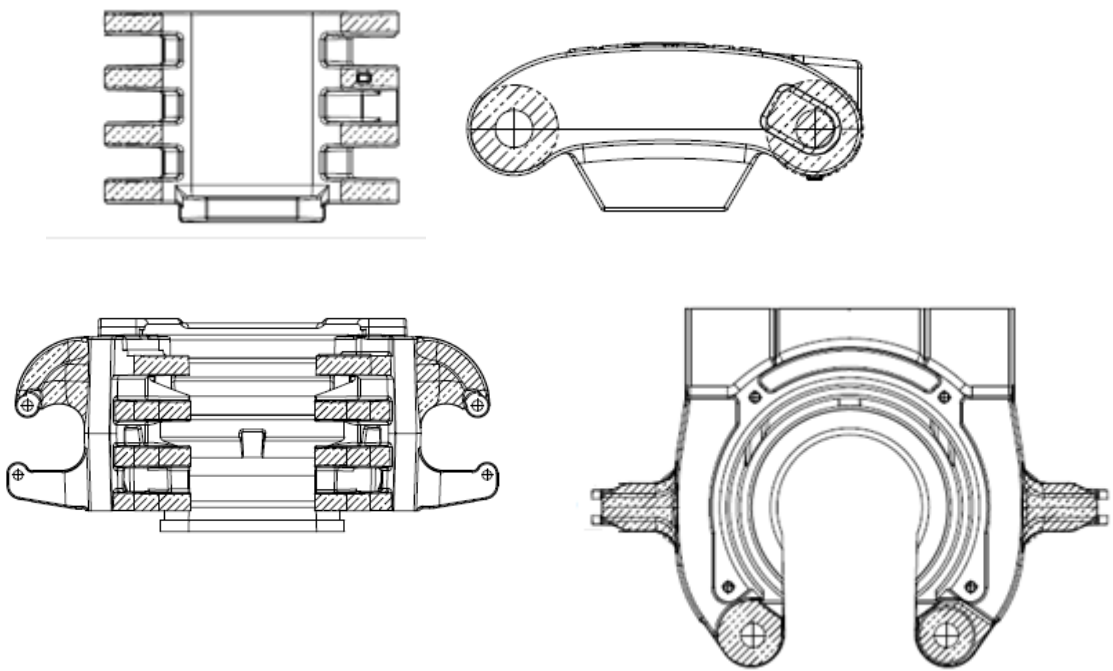

Figure 8



Hatched areas are load bearing and critical

TROUBLESHOOTING

Area	Issue	Failure Mode	Probable Solution
Slips	Not locking in the set (down) or release position (up)	Locking mechanism needs adjustment	Remove the yoke retainer pin and adjust the yoke eyebolt by turning it to a suitable location
		Worn locking mechanism components	Replace the overload plunger, spring cam lock or cam rod if worn
	Does not unlock at the set position (down)	Locking mechanism is stuck	Use a small pry bar and hammer to move up the bottom of the lock rod to release the locking mechanism. Remove the locking mechanism for evaluation and repair
	When released, slips do not swing wide open	Hinge pin and/or spring may be damaged or worn	Inspect and replace if necessary
	They are uneven when placed at the release pipe position	Bent yoke	Remove and straighten yoke if possible or replace
	Slips move slow in either direction (Pneumatic)	Insufficient air supply	Verify air source and adjust pressure as needed
		Air Leak	Replace worn/damaged hoses
		Control Valve leak	Replace
		Cylinder Seal leak	Replace
	Slips sticking in the E/S cone	Insufficient lubrication	Remove slips. Clean the cone and slip backs. Apply light machine oil and reinstall
Pipe slides through the slips when in the down position or pipe surface is damaged or distorted	Incorrect slip / insert combination. Slip set up is not correct size for the tubular used	Pull slips and make changes to match the tubular	
Yoke	Bent	Guide plates do not match the tubular size.	Remove and straighten yoke if possible or replace as needed

Table 4

STORAGE AND TRANSPORTATION



The elevator / spider assembled with the slips should never be thumped down against the floor. It may jam the locking mechanism

During warehouse storage

- Unpainted surfaces should be coated with rust preventing agent
- Prevent excessive exposure to water and moisture
- Clean the tool and its air couplings after use - steam cleaning as needed; remove mud, debris and any other substances
- Transport the unit in a suitable container or on a pallet

COMPONENTS

350 BODY SUB-ASSEMBLY PN:T28501-1-KIT		
Part No	Description	Qty
T28501-1	TI MFG 350 TON ELEVATOR/SPIDER BODY	1
T33494	YOKE, 350 TON	1
T11541	UPPER LINK BLOCK PIN	2
T26257	LINK RETAINER	2
T28509	YOKE PIVOT PIN	2
080019	YOKE PIN COVERS	2
940325-5	SLIP CONE OILERS	3
T28510	LOCKING MECHANISM	1
040242	SCREW	1
350 DOOR SUB-ASSEMBLY PN: T28502-KIT		
T28502	TI MFG 350 TON ELEVATOR/SPIDER DOOR	1
T28504	STATIONARY HINGE PIN	1
T28505	REMOVABLE HINGE PIN	1
080079	FREEZE PLUG	1

Table 5

Components continued

350 TON PNEUMATIC SUB-ASSEMBLY PN: T28501-1-AIRKIT **		
Part No	Description	Qty
060049	CYLINDER	2
060050	KNUCKLE	2
T50006260Y-1	TREADLE VALVE	1
T33492Y-1	CONTROL VALVE MOUNTING BRACKET	1
T33492Y-2	AIR CYLINDER MOUNTING BRACKET	1
T33492Y-5	COVER PLATE, AIR OPERATED	1
030022	PIPE COUPLING	1
030184	MALE QUICK DISCONNECT COUPLING	1
030044	TEE, RUN	2
030160	90 DEGREES ELBOW	2
030195	ELBOW, 90 DEGREE	4
030326	M-NPT / F-NPT 90 DEG	1
060016	NEEDLE VALVE	1
030169	NIPPLE, PIPE, BLACK STEEL	1
050108	HOSE	3
050109	HOSE	1
030134	NIPPLE, PIPE, HEX, STEEL	1
060061	SINGLE DIRECTION FLOW CONTROL VALVE-BRASS	1
T28512-EXT	SLIP LOCK HANDLE EXTENSION	1
T33495	BACKPLATE	1

Table 6

***Kit is for current TIOT frame. Older or non-TIOT manual frames require additional parts.*

250 / 350 Locking Mechanism - P/N T28510			
Item	Part No	Qty	Description
1	T26273	1	SLIP LOCK BRACKET
2	T26275-1	1	LOCKING CAM OR PORKCHOP
3	T26277	1	BRACKET PIN
4	T26278	1	LOCK SPRING
5	T26279	1	SPRING PLUNGER
6	T26280-1	1	SPRING PLUNGER GUIDE
7	T27458	1	OVERLOAD PLUNGER
8	T28511	1	LOCK ROD
9	T28512	1	SLIP LOCK HANDLE
10	T28513	1	YOKE EYE BOLT
11	T28514-1	1	YOKE CLEVIS
12	040025	1	NUT, NYLOC
13	T945039-75	1	TI CAM EXTENSION SPRING
14	T945040-2	1	SLIP LOCK OVERLOAD SPRING
15	040022	1	FLAT HEAD SOCKET HEAD
16	040014	2	WASHER, FLAT, 1/2"
17	040020	1	SCREW, SET, STEEL, CUP POINT
18	080011	2	CAM SPRING COTTER PIN
19	080012	2	COTTER PIN
20	080013	1	GREASE FITTING
21	080014	2	RETAINING RING
22	080015	1	PIN, CLEVIS, STEEL, ZINC PLATED,

Table 7

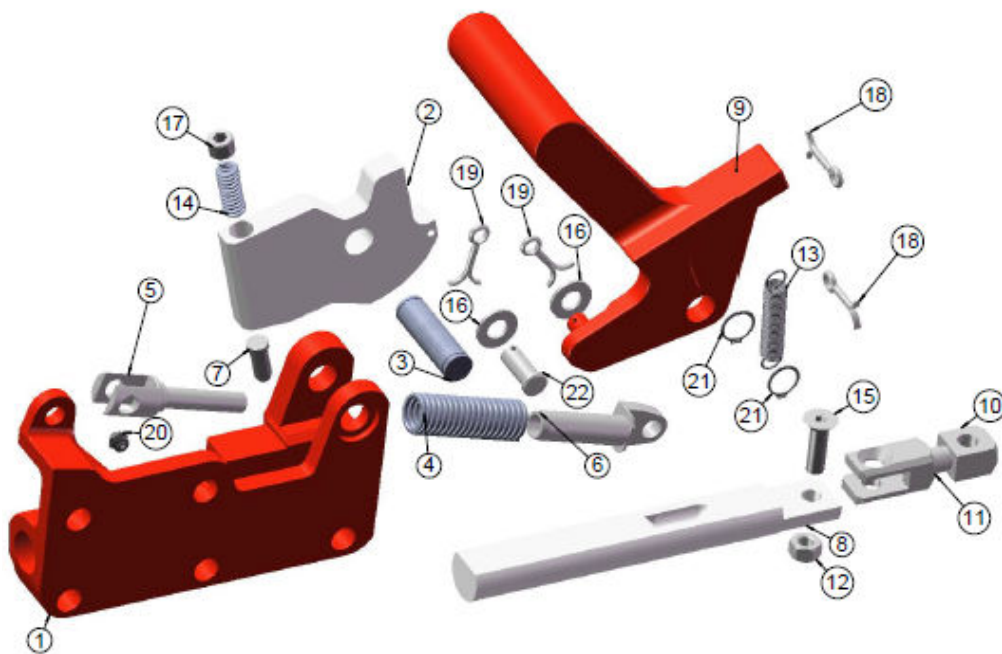

Figure 9; Locking mechanism

350 TON BOLT KIT PN: T33492-BKIT		
Part No	Description	Qty
040046	PLAIN SOCKET HEAD	2
040054	WASHER, LOCK, SPLIT	5
09-5006	WASHER FLAT	4
09-5106	WASHER LOCK	4
040056	SCREW, CAP, HEX HEAD	4
040119	WASHER, LOCK, SPLIT	2
040222	HEX HEAD CAP SCREW, YELLOW ZINC	4
040223	HEX HEAD CAP SCREW	2
040224	HEX NUT	2
040151	WASHER, FLAT	8
040135	NUT, HEX, NYLOC INSERT	4
02-0070	GREASE FITTING	6
080044	PIN, COTTER, ZINC PLATED STEEL	2
080058	PIN, COTTER	4
080018	PIN, COTTER	4
939099-85	LINK BLOCK BOLT	1
080047	CLEVIS	4
040036	SCREW, CAP, HEX HEAD	7
040050	SCREW, CAP, HEX HEAD	4
040047	SCREW, CAP, SOCKET HEAD	3
040038	WASHER, LOCK	7

Table 8

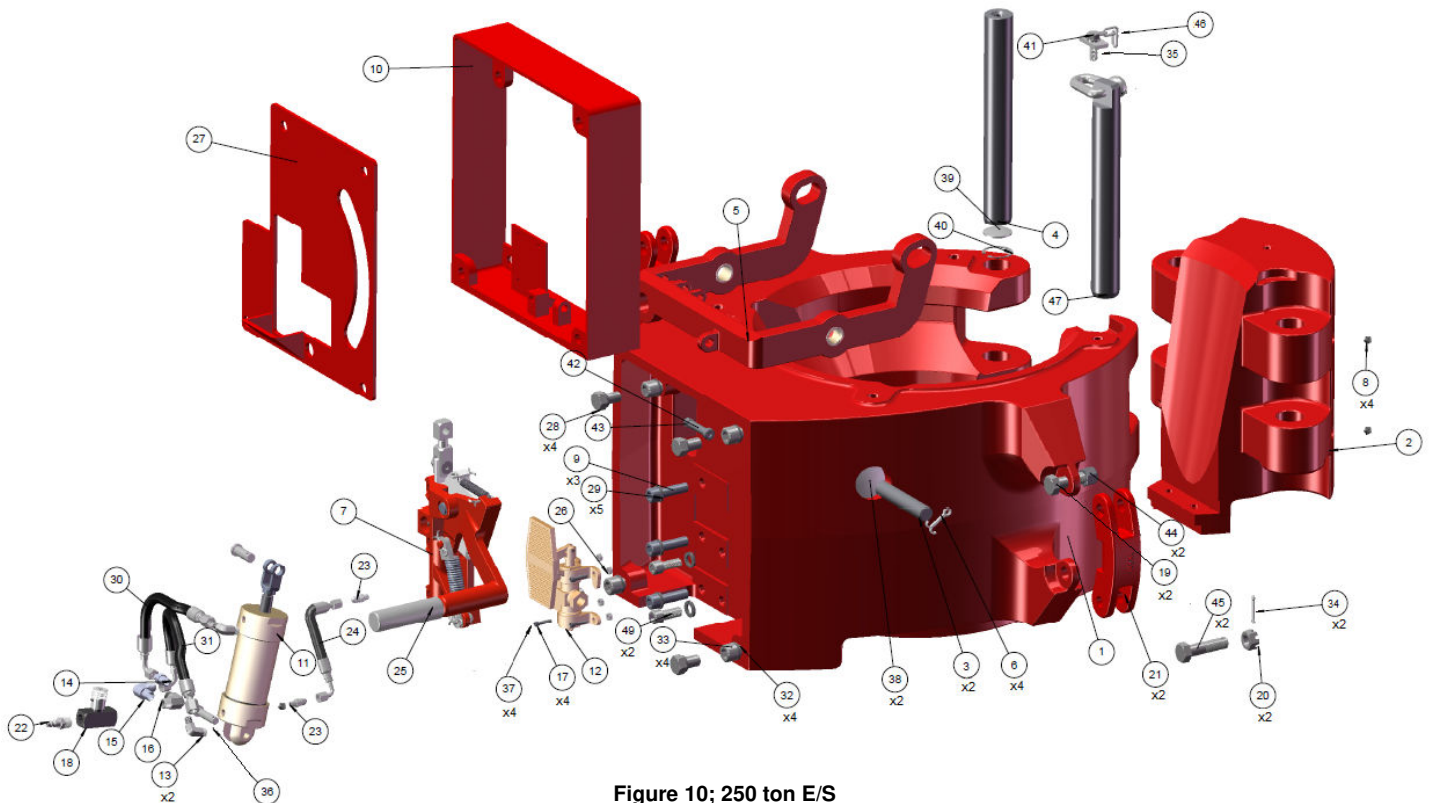

Figure 10; 250 ton E/S

Drawing	250 TON ELEVATOR SPIDER		Air	Manual
Item #	Part No	Description	Qty	Qty
1	T50367Y	BODY	1	1
2	T50368	DOOR	1	1
3	T30999	PIVOT PIN, YOKE	2	2
4	T30997	HINGE PIN, STATIONARY	1	1
5	T31039-AIR	YOKE, 250 TON	1	na
5	T31039	YOKE, 250 TON	na	1
6	080031	PIN, COTTER	4	4
7	T28510	LOCKING MECHANISM	1	1
8	080013	GREASE FITTING	4	4
9	040047	SCREW, CAP, SOCKET HEAD	3	3
10	T50006262	FRAME EXTENSION	1	na
11	060053	AIR CYLINDER	1	na
12	T50006260Y-1	TREADLE VALVE	1	na
13	030024	ELBOW 90 DEG	2	na
14	030036	CONNECTOR, STRAIGHT	1	na
15	030007	ELBOW 90 DEG	1	na
16	030160	ELBOW 90 DEG	1	na
17	040151	WASHER	4	na
18	060016	NEEDLE VALVE	1	na
19	040026	UPPER LINK BLOCK PIN	2	2
20	040029	HEX NUT, SLOTTED	2	2
21	T9519	LINK	2	2
22	030184	QUICK DISCONNECT	1	na
23	030159	CONNECTOR	2	na
24	050040	HOSE	1	na
25	T28512-EXT	SLIP LOCK HANDLE EXTENSION	1	na
26	040113	NUT	4	na
27	T50006264	COVER PLATE, AIR OPERATED	1	na
27	T31015	COVER PLATE	na	1
28	040056	SCREW, CAP, HEX HEAD	4	4
29	040054	WASHER, LOCK, SPLIT	5	5
30	050041	HOSE	1	na
31	050042	HOSE	1	na
32	040133	WASHER, LOCK, SPLIT	4	na
33	040132	SCREW, CAP, SOCKET HEAD	4	na

Table 9

Components continued

Drawing	250 TON ELEVATOR SPIDER		Air	Manual
Item #	Part No	Description	Qty	Qty
34	080018	PIN, COTTER	2	2
35	040014	WASHER, FLAT	1	1
36	080051	CLEVIS	1	na
37	040144	SCREW, CAP, SOCKET HEAD	4	na
38	080019	YOKE PIN COVER	2	2
39	080017	FREEZE PLUG	1	1
40	080016	SNAP RING	1	1
41	040012	SCREW, CAP, HEX HEAD	1	1
42	040024	BOLT, SHOULDER, SOCKET HEAD	1	1
43	040025	NUT, NYLOC	1	1
44	040027	NUT, HEX, NYLOC INSERT	2	2
45	T50364-6	LINK RETAINER	2	2
46	T30993	DOOR PIN RETAINER ASSEMBLY	1	1
47	T30991	HINGE PIN, REMOVABLE	1	1
49	040110	SCREW, CAP, SOCKET HEAD	2	2
50*	040030	WASHER LOCK, SPLIT	6	6
51*	040174	SCREW, CAP, HEX HEAD	6	6

*not shown

Table 9 continued

ANCILLARY COMPONENT LIST

Slip Size	PIPE SIZE	SLIP ASSEMBLY	BOTTOM GUIDE ASSEMBLY	BODY GUIDE	DOOR GUIDE	BELL GUIDE	INSERT-QTY	INSERT RETAINER	UPPER GUARD	TOP GUIDE
250 Ton Elevator/Spider										
5 1/2" x 4 1/2"	4 1/2"	T50006293-412	T51922	T31038	T31016	T31021	24785 - 27	T31014	T50422-2	T51927
5 1/2" x 5"	5"	T50006293-500	T51922	T31038	T31016	T31021	24783 - 27	T31013	T50422-2	T51927
5 1/2"	5 1/2"	T50006293-512	T51922	T31038	T31016	T31021	16407 - 27	T31012	T50422-2	T51927
6 5/8"	6 5/8"	T50006294-658	T51924	T31037	T31017	T31021	25474 - 45	T31011	T50422-2	T51928
7 5/8" x 7"	7"	T50006294-700	T51924	T31037	T31017	T31021	26750 - 45	T31010	T50422-2	T51928
7 5/8" x 7 5/8"	7 5/8"	T50006294-758	T51924	T31037	T31017	T31021	16407 - 45	T31009	T50422-2	T51928

Table 10

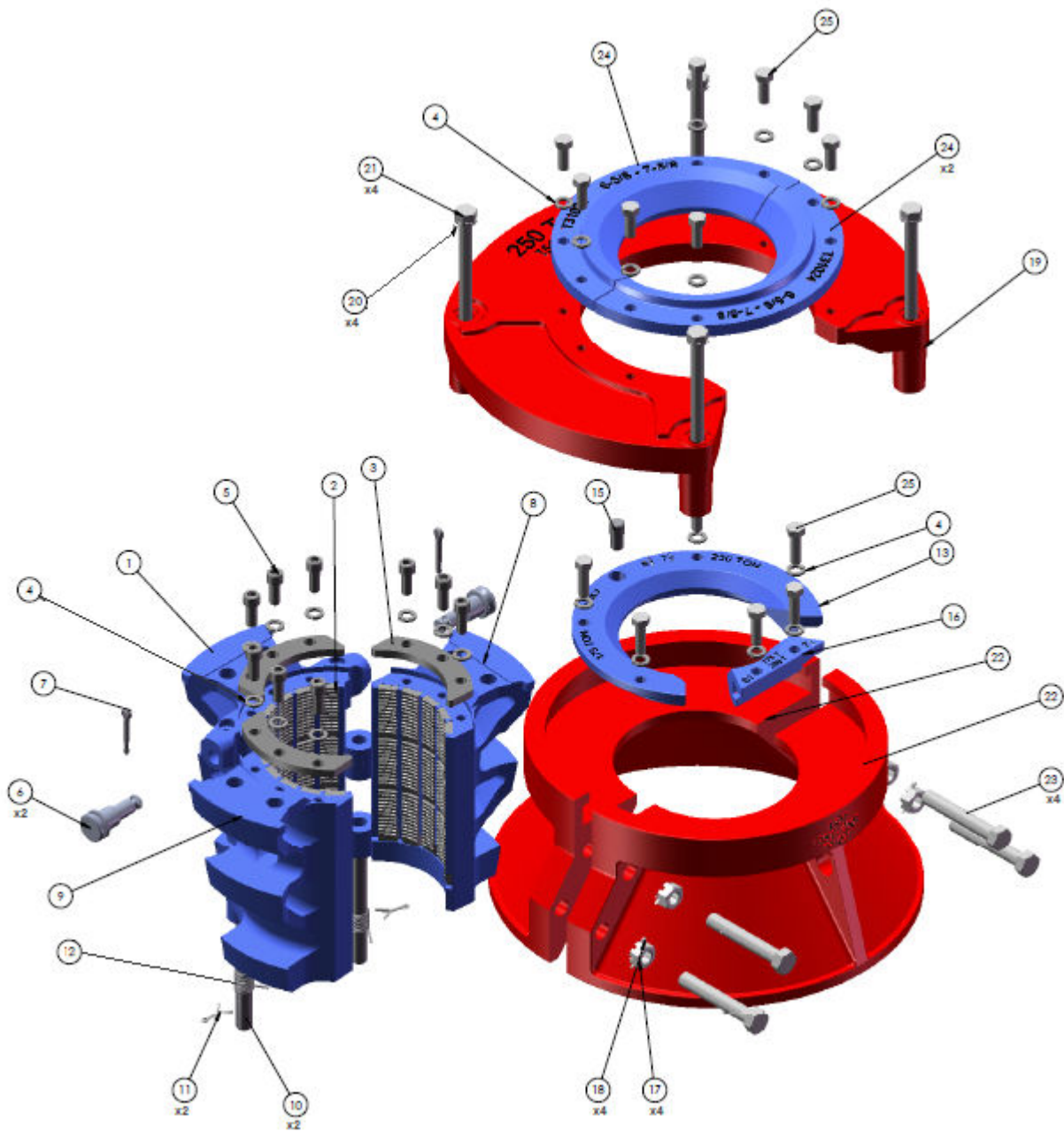

Figure 11; 250 ton

Ancillary Component List continued

250 Ton Slip Size		5 1/2	7 5/8
Item #	Description	Part Number	
1	Center Slip	T50384-1	T50381-1
2	Insert	<i>see Ancillary</i>	
3	Insert Retainer	<i>see Ancillary</i>	
4	Washer, Lock	T50808-N-C	
5	Screw	T94286-821	T50110-12-C
6	Slip Retainer Pin	T26338	
7	Cotter Key	T50364-4	
8	Left Slip	T50386	T50383
9	Right Slip	T50385	T50382
10	Slip Hinge Pin	T31001	
11	Hinge Pin Cotter	T51403-10	
12	Slip Spring (Left & Right)	T31002	T30996
13	Body Guide	<i>see Ancillary</i>	
15	Pin	T34300	T26349
16	Door Guide	<i>see Ancillary</i>	
17	Nut, Hex	040029	
18	Cotter Pin	080011	
19	Upper Guard	<i>see Ancillary</i>	
20	Washer, Lock	040119	
21	Screw	040073	
22	Bell Guide, half	<i>see Ancillary</i>	
23	Screw	040107	
24	Top Guide, half	<i>see Ancillary</i>	
25	Screw	040174	

Table 11

Slip Size	PIPE SIZE	BOTTOM GUIDE ASSEMBLY	BODY GUIDE	DOOR GUIDE	BELL GUIDE	INSERT - QTY	INSERT RETAINER	UPPER GUARD	TOP GUIDE
350 Ton Elevator/Spider									
5 1/2" x 4 1/2"	4 1/2"	T51936	T28569	T28579	T28599	24785 - 36	T26792-1	T28570-1	T51949
5 1/2"	5 1/2"	T51936	T28569	T28579	T28599	16407 - 36	T26791	T28570-1	T51950
5 3/4"	5 3/4"	T51937	T28568	T28578	T28599	29254 - 48	T27036-1	T28570-1	T51951
6 5/8"	6 5/8"	T51937	T28566	T28577	T28599	24784 - 48	T26790	T28570-1	T51952
7"	7"	T51937	T28566	T28577	T28599	16407 - 48	T26324	T28570-1	T51952
7 5/8"	7 5/8"	T51938	T28565	T28576	T28599	16407 - 60	T27492	T28570-1	T51953
8 5/8"	8 5/8"	T51939	T28564	T28575	T28599	15660 - 60	T26320	T28570-1	T51954
9 5/8"	9 5/8"	T51940	T28563	T28574	T28599	15660 - 72	T26321	T28570-1	T51955
10 3/4"	10 3/4"	T51941	T28562	T28573	T28599	15660 - 72	T26320-1	T28570-1	T51956
11 3/4"	11 3/4"	T51942	T28561	T28572	T28599	15660 - 72	T28597	T28570-1	T51957
13 3/8"	13 3/8"	n/a	n/a	T28571	T28599	15660 - 84	T28581	T28570-1	T51958

Table 12

Every Company has to have a Toolbox.

At Texas International Oilfield Tools

we provide the tools to fuel the world!



The terms VARCO, VARCO-BJ, and BJ are trademarks of Varco I/P, Inc., National Oilwell Varco, L.P., or their affiliates. Texas International Oilfield Tools is not an authorized distributor of any Varco I/P or NATIONAL OILWELL VARCO product. Texas International Oilfield Tools is not affiliated with Varco I/P, Inc., National Oilwell Varco, L.P., or their affiliates. Varco I/P, Inc., National Oilwell Varco, L.P., and their affiliates do not endorse any Texas International Oilfield Tools' products or replacement parts.