



Power Unit – Electrohydraulic Operation Manual

CONFIDENTIALITY STATEMENT

This document contains confidential information. All rights including copyright, confidential information, trade secrets and design rights are owned by Texas International Oilfield Tools, LTD (TIOT, Texas International, and Texas International Oilfield Tools). No use or disclosure is to be made without prior written permission of Texas International Oilfield Tools, LTD.

Revision History

Rev	Date	Reason
B	01/26/15	Revised format
C		

Description of Change

Rev	Change
B	Combined Hydraulic and Electrical Troubleshooting, incorporated Safety Issues into other sections. Replaced Marathon manual with WEG and added Appendix B, C, D and E

TABLE OF CONTENTS

GENERAL	5
CONVENTIONS	5
SAFETY	6
SPECIFICATIONS	6
INSTALLATION	8
HYDRAULIC.....	10
OPERATION	13
ADJUSTMENTS.....	14
PREVENTIVE MAINTENANCE	16
TROUBLESHOOTING	17
STORAGE AND TRANSPORTATION	19
PARTS LIST.....	20
SPARE PARTS LIST.....	22
WEG DATA SHEET 60 HERTZ	APPENDIX A
WEG DATA SHEET 50 HERTZ	APPENDIX B
PUMP CODE BOOK	APPENDIX C

Table of Contents continued

PARKER FILTER DATA..... APPENDIX D

ISO FLUID CLEANLINESS LEVELSAPPENDIX E

GENERAL

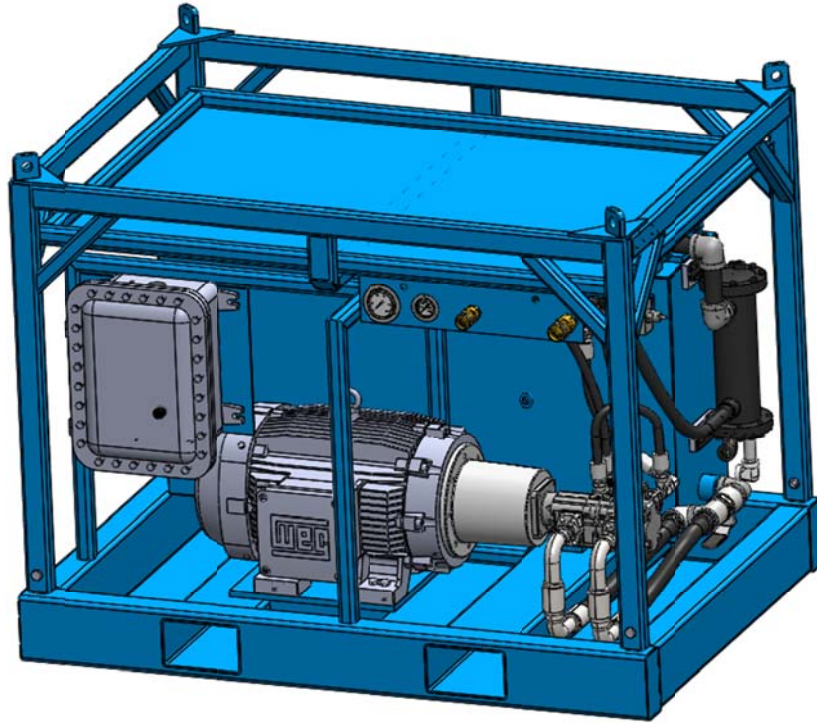

Figure 1: Power unit

Texas International Oilfield Tools (TIOT) offers a Power Unit which operates many types of hydraulic equipment. The unit is mounted on a skid for easy transport.



Large forces are involved in using this device. Operate this equipment with extreme caution

CONVENTIONS



IMPORTANT SYMBOL IDENTIFICATION	
	WARNING to Operators / Users
	CAUTION to Operators / Users
	NOTIFICATION to Operators / Users

Table 1

SAFETY

Texas International's equipment is used and installed in controlled rig environments involving hazardous operations and situations.

All personnel performing installation, operations, repair or maintenance on this Power Unit must have knowledge of rig procedure. All crew in the vicinity of operations should be trained on rig safety and tool operation.

SPECIFICATIONS

Item	Size			Dry Weight (lbs)	Full Weight (lbs)
	L	W	H		
Power Unit	97-1/8"	52"	60-7/16"	3159	4023

Table 2

Item	Power (hp)	Speed (rpm)	Frequency (hertz)	Voltage (3 phase)	Amperage	Features
Motor	75	1500	50	190/380	206/103	Explosion proof, Continuous duty
	100	1800	60	230/460	226/113	

Table 3

Item	Stage	Gear	Displacement	Mount	Motor Frequency (hz)	Pressure (psi)	Flow Rate (GPM)	Max operating pressure
Pump	Dual	Heavy Duty	5.10 cu in/rev	SAE C	50	2500	66	2500 psi
						1000	31	
					60	2500	79.5	
						1000	37.5	

Table 4

Item	Features	Maximum (gal)	Working (gal)	Recommended operating temp
Hydraulic Tank	Sight and temperature gauges	135	118	100 - 130 deg F
	Filtered breather			
	Top access hatch			
	Fully welded steel construction			

Table 5

Item	Features
Return Filter	Dirty element
	No element
	Operation OK
	Full flow return line

Table 6

Item	Factory set
Relief valve - adjustable	2500 psi
Unloader valve - adjustable	1000 psi

Table 7

Standard gauges
Output Pressure 0 - 3000 psi oil filled
Tank Temperature
Tank Level
Filtration status

Table 8

Optional	Gauges
	Voltmeter
	Motor Temp
	Hour Meter
	Tachometer
	Remote Start/Stop
	Low Oil Level Shutoff

Table 9

Item	Features
Frame	ASTM A36 steel construction
	Lift eyes on top
	Fully welded belly pan
	Full length forklift tubes
	Removable top
	Drain (plugged) 2"
Starter Station	Explosion proof
	Sealed cast aluminum

Table 10

Item	Features	Operating pressure	Max flow rate
Oil Cooler	Oil/water type	500 psi	80 GPM
	Oversized for hot climates		
	1" NPT water inlet and outlet		
	2:1 Oil to Water ratio		

Table 11

Motor	TIOT Part No.
75 HP	T1136E-50
100 HP	T1136E-60

Table 12



Do not exceed the system's rated pressure or over tighten fittings

INSTALLATION

- 1) Find the best location
- 2) place the unit, connect power, and make hydraulic connections
- 3) test the unit for proper operation

The electrohydraulic power unit requires a source of line or rig power capable of delivering the voltage and amperage needed.



Always ensure the unit is properly grounded

It's important to consider electric and hydraulic line losses from size, length and pressure (hydraulic) in choosing where to place the unit. The sizes of the hydraulic lines should be large enough to limit friction losses to 300 psi or less. This may mean using hoses larger than the connections on the unit. For connection instructions, see Hydraulic section page 10.



Proper hose connection is required to fully open the check valves in the hose couplings

The presence of hazardous locations should be compared with the rating of the power unit for compatibility. Ideally, the unit will be located as close as possible to the electrical power source and the equipment to be powered. Ensure power cables are placed where they won't be cut, nicked, or squeezed.



The motor develops almost 300 foot-pounds (ft/lb) of torque while running, 485 ft/lb with the rotor locked and foreign objects (i.e. loose clothing, long hair, etc.), can be drawn in - with disastrous results



Main breaker must be off and “locked out” until all wiring and wiring inspection is done. Wiring must be performed by a qualified, licensed electrician

When properly connected, the motor rotates clockwise when looking from the pump towards the motor.



Replace the cover on the pump to motor coupling housing once rotation is verified

Transport the power unit using **only** the forklift tubes provided shown in Figure 2.

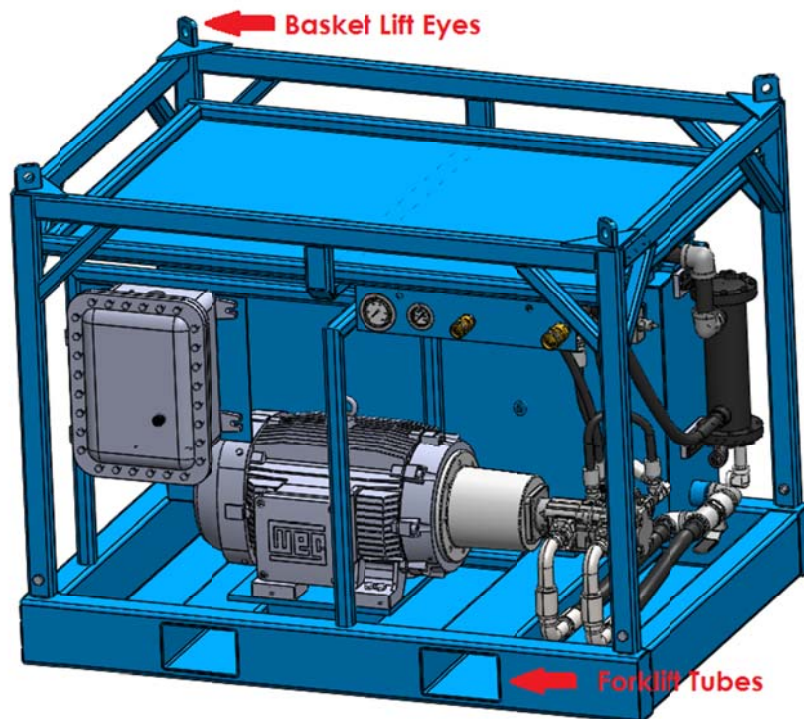

Figure 2

Installation continued



Use the top lift eyes to remove the top basket from the frame/skid - NOT designed for lifting entire skid

If the unit is full of hydraulic oil the center of mass is approximately in the center of the forklift tubes. If the unit is empty, the center of mass is still between the forklift tubes but biased to the motor end.



Positioning forklift forks in other positions can damage the unit and can be dangerous to personnel

Ensure the unit does not shift or move from its intended location.

HYDRAULIC

The power unit during operation heats the hydraulic fluid. If the reservoir temperature exceeds 150 degrees Fahrenheit (F), shut down the unit and let it cool. If this happens regularly, have unit repaired.



Be careful not to expose skin to hot hydraulic fluid – it can scald

Time and Temperature Relationship to Severe Burns

<i>Water temperature</i>	<i>Time for a third degree burn to occur</i>
155° F 68° C	1 second
148° F 64° C	2 seconds
140° F 60° C	5 seconds
133° F 56° C	15 seconds
127° F 52° C	1 minute
124° F 51° C	3 minutes
120° F 48° C	5 minutes
100° F 37° C	safe temperature for bathing

Figure 3*

*American Burn Association SCALD INJURY PREVENTION, Educator's Guide

The hydraulic fluid may be under pressures as high as 2500 psi. Fluid can be sprayed some distance, creating a slip hazard. If a leak occurs, shut down the power unit

immediately and repair. Hydraulic fluid can irritate the skin – for skin contact, wash and rinse the affected area. If fluid comes in eye contact, use an emergency eyewash or flush with saline solution. If not available, flush with distilled or lastly, tap water. Seek medical attention after flushing.



Avoid the hydraulic fluid spray– it can be injected through the skin at high pressures

The power unit is equipped with Snaptite 78 series quick disconnect couplings (or equivalent), one (1) inch for the supply line and one and a quarter (1-1/4) inch for the return line. These couplings contain check valves to prevent the loss of hydraulic oil during connection and disconnection.



Proper connection is required to fully open the check valves in the couplings

Connect the hoses as follows:

1. Wipe the connections clean as required to remove dirt and dust
2. Connect the one (1) inch pressure hose to the one (1) inch coupling on the unit by engaging the mating coupling halves and forcing the connectors together while rotating the threaded sleeve on the hose connector
3. Using the same method as for the one (1) inch hose, connect the one and a quarter (1-1/4) inch return hose



The motor and pump must be off (locked out) before connecting hoses



If either the pressure or return fittings are not fully tightened, the check valve will cause a restriction in the flow. This can result in overheating the fluid, poor tool operation and damage to equipment

Hoses, connections and fittings should be chosen carefully so as not to cause excessive restriction. Restriction in a hydraulic system equals pressure drop and pressure drop equals heat. Improper connection or restrictive circuits can cause a serious loss of power and will generate heat uselessly. Choose short, large inside diameter hoses whenever possible over long, skinny ones.



High temperatures decrease the useful life of the hydraulic oil, the hoses and the seals in the equipment being powered

Low hydraulic fluid level can cause overheating, or in worst cases severe damage to the pump and even the associated tools it's driving. Keep fluid up to at least the minimum on the sight gauge. Observe the filtration monitor to be sure it's operating in the green (OK) range. Change the filter if it's not.

Recommended Oils
Mobil DTE 24
Castrol Hyspin VG 32
Royal Purple Syndraulic 32
Shell Tellus 32
PetroCanada Environ AW 32
ISO viscosity grade 46*

* for warmer climates

Table 13

TEXAS INTERNATIONAL OILFIELD TOOLS, INC.
ELECTROHYDRAULIC POWER UNIT
HYDRAULIC SCHEMATIC
4/28/08

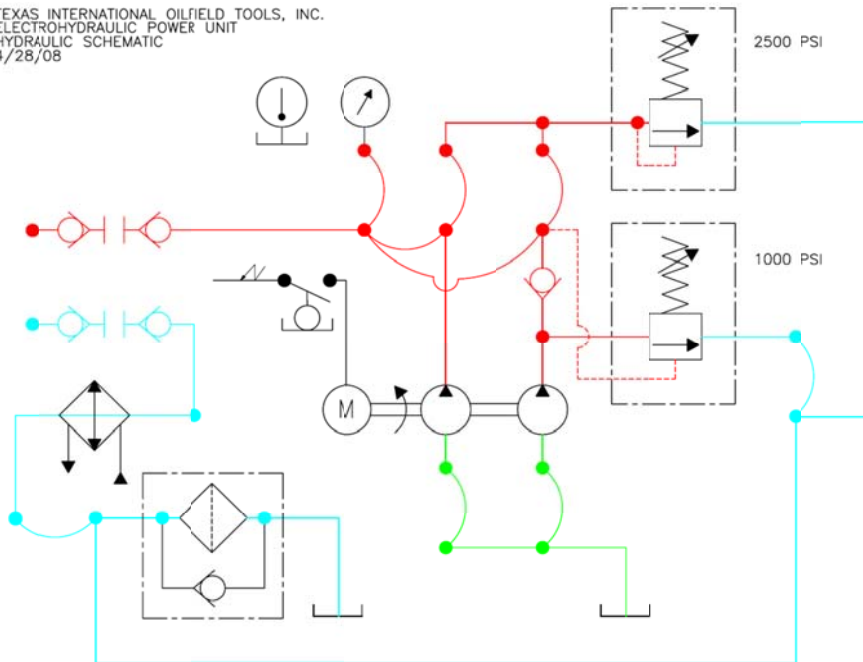

Figure 4

Color Line	Function
Red	Pressure
Aqua (blue)	Return
Green	Suction

Table 14

OPERATION

On the power unit, an electric motor drives a dual stage pump at a setting of 1500 rpm (50 hertz (hz)) or 1800 rpm (60 hz). The pump draws hydraulic fluid from the tank and delivers hydraulic fluid up to 2500 psi on the pressure line, adjustable at the unloader valve (preset at 1000 psi). The pump delivers 66 GPM at 50 hz and 79.5 GPM at 60 hz. As the line pressure decreases to 1000 psi, volume decreases to 31 or 37.5 GPM (depending on frequency). The higher volume stage of the pump is literally “unloaded” at 1000 psi, simply transferring its volume from the tank directly back to the tank through the return full flow filter with only a few psi pressure. The lower volume stage of the pump is always supplying fluid to either the output disconnect or the relief valve at system pressure. The relief valve has a maximum (factory) setting of 2500 psi. The 2500 psi setting is the maximum recommended output pressure for the standard pump. Theoretically the unit could produce 2971 psi at full motor rated output, but pump life will be shortened, possibly dramatically. See the Adjustment section on page 14 for how to change these setting.



The unit is slightly overpowered for long service life. Exceeding the factory set pressures is not recommended

For startup and shut down:

- 1) Push the START button on the main enclosure or on the remote start/stop switch
- 2) To turn the unit off, press in the STOP button



Figure 5



If the power unit shuts down prematurely, press the RESET button on the main enclosure. If this happens repeatedly, an abnormal condition exists which must be found and fixed before continuing operation

Cooling is provided on the return line with a two pass oil to water cooler (item 20 on Figure 7). The cooler is capable of removing nearly the entire horsepower rating in heat, keeping hydraulic temperatures low for safety and for system longevity and is easily achieved with a reasonable flow of cooling water. Controlling the temperature is done by manually adjusting the flow of the cooling water source while observing the thermometer.

Full filtration is equipped on the return line. The filter (item 7 on Figure 7) is mounted on the top of the tank and has a filter condition indicator mounted on the side of the filter housing. The condition indicator shows when the filter is operating properly, is bypassing (dirty filter), or is missing. Keeping the filter in good condition is strongly recommended, as dirt in the system will increase wear in the pump, valves and connected tools or other hydraulic tools.

Hoses and fittings have JIC swivel connections, SAE flange connections, or NPT connections. A shutoff valve (Figure 7, item 12) is on the tank so it can be drained and serviced.

ADJUSTMENTS

The relief valve adjustment is shown in Figure 12 - item 13. Turning the adjustment screw clockwise (in) raises the relief pressure and turning it counterclockwise lowers the relief pressure. Tools required: 5/32" Allen wrench (screw) and 9/16" wrench (locknut).



Adjustments should be made with the oil at normal operating temperature of 80 to 130 degrees F

The relief valve setting can be determined by running the unit with no equipment connected to the quick disconnects and observing the pressure reading on the panel gauge.



Do not operate the unit with equipment disconnected for over five (5) minutes. Keep temperature at or below 130 degree F

Adjusting the unloader valve (shown in Figure 7 - item 6) requires equipment NOT supplied with the power unit (a flow meter (sample shown in Figure 6), JIC plugs, caps and reducers listed below). Changing the setting from the factory setpoint of 1000 psi is not recommended. The adjustment procedure to follow is given in case of field emergency.

1. Back off the relief valve so the relief pressure is well below 1000 psi. As low as it can go is good
2. Shut down the system
3. Disconnect the high volume pump hoses to the relief valve and to the pressure outlet and plug the hoses with one (1) inch JIC plugs
4. Cap one (1) JIC outlet on the high volume pump with a one (1) inch JIC cap
5. Attach the one (1) inch to three eighth (3/8) inch JIC reducer to the other high volume pump outlet
6. Connect the gauge hose and the gauge, connecting them to the one (1) inch to the three eighth (3/8) inch JIC reducer
7. Reduce the setting on the unloader valve to minimum by turning knob counterclockwise
8. Start the system



Watch for plugged hoses – they might move

9. Adjust the unloader valve to show 1000 psi pressure on the gauge
10. Stop the system, removing all plugs, caps and test equipment and reconnect the hoses
11. Start the system and set the relief valve for 2500 psi



Figure 6

PREVENTIVE MAINTENANCE



This is a suggested PM schedule. The tool owner has the responsibility to adjust the program according to actual tool usage



For hydraulic units, disconnect lines and drain system's pressure before maintenance

Verify that the equipment to be operated is properly connected to the power unit as specified in the Hydraulic section on page 10. Be sure the equipment being operated is an 'open center' hydraulic circuit – meaning that in the neutral position the circuit has full flow from the inlet to the outlet. If not, a 'closed center' adapter must be installed.

Cracks or the appearance of damage on the hydraulic hoses or electrical cabling can indicate the need for repair, even impending failure, and requires prompt attention.

Daily – While in use

- Verify power unit is in a secure and safe location
- Inspect the hydraulic hoses for worn or scraped areas, bubbles, wrinkles or any other wear – if found, replace
- Verify power cables and hydraulic hoses are not a trip hazard and can't be pinched or cut
- Check for exposed wires/breaks in the insulation and that electrical connections are secure
- Notice the hydraulic level and ensure tank is filled to the proper level



Most items in the unit are lubricated by the hydraulic fluid and don't require other lubrication other than to ensure the hydraulic fluid is clean

- Verify the cooling water supply is connected and flowing



Oil temperature will increase 80 degrees Fahrenheit in 20 minutes without water flow

- Ensure the shutoff valve to the pump inlet is fully open
- Keep the power unit exterior clean of oil, dust, dirt, water or chemicals
- Once operating, check the return filter state

Quarterly

- Replace return filter or earlier if the filter's indicator gauge shows a dirty element (before needle is in the red)
- Change the hydraulic fluid every three (3) to six (6) months – see recommended fluid on Table 13

Yearly

- Apply Mobil Polyrex® EM grease (see Appendix A) to grease fittings on motor every 9000 hours

TROUBLESHOOTING

Failure Mode	Possible Cause	Possible Solution
Pump excessively noisy	Pump inlet flow	Ensure that nothing in tank blocks tank outlet
		Verify suction shutoff valve is wide open
	Oil viscosity is too high	Change oil to a lower ISO VG grade
	Air	Pour oil over suction side fitting - if noise stops, disassemble, retape and reassemble
	Pump rotation is wrong	Shut down and change electrical hookup. Verify rotation is counterclockwise - looking from the motor to the pump
	Loose or worn parts	Verify assembly is tight - replace worn out parts
Hydraulic system overheating	Cooling water - insufficient	Verify water flow rate is at least 16 GPM
	Relief valve setting	Reset to a maximum of 2500 psi
	Fittings loose	Verify fittings fully tightened
	Oil viscosity	Change oil
	Excessive internal leakage	Check parts for wear - replace/repair
		Check for contamination
	Excess friction	Look at moving parts inside pump for proper fit
Leaks in pump	Repair/replace valves	
Excessive wear of moving parts	Oil contaminated	Change oil. Replace filter element. Clean breather
	Motor to pump alignment	Verify fastener tightness. If OK, replace motor to pump housing and coupling
	Relief valve setting	Reset to a maximum of 2500 psi
	Air	Pour oil over suction side fitting - if oil disappears, disassemble, retape and reassemble
	Oil viscosity is too low	Change oil to a higher ISO VG grade

Table 15

Troubleshooting continued

Failure Mode	Possible Cause	Possible Solution	
Flow rate (tool speed) is low	Pump inlet flow	Ensure that nothing in tank blocks tank outlet	
		Verify suction shutoff valve is wide open	
	Pump	Inspect parts and replace as necessary	
	Oil is bypassing	Check relief and unloader valves - reset	
	Fittings	Confirm fittings are tight	
	Oil viscosity	Change oil to a proper ISO VG grade	
	Hoses	Use shorter or larger hoses	
Motor speed is low	See 'motor runs and then slows/stops' to follow		
Hot or noisy operation	Misalignment	See 'motor vibrates' to follow	
	Grease	Insufficient	Lubricate per APPENDIX A
		Deterioration	Remove old and lubricate per APPENDIX A
		Excess	Reduce quantity of grease
Motor loose	Check mounting bolts are tight		
Motor will not start	Electrical Connections	Verify wiring connections/tighten	
		Check voltage/amperage/phase	
	Relays tripped	Allow at least five (5) minutes cooling time, then push the reset button followed by the start button	
	Starter heater/relay	Replace	
	Start button damaged	Replace	
	Starter coil damaged	Replace	
	Short circuited stator	Rewind motor	
	Motor overloaded	Adjust or replace hydraulic valves	
Motor stalls	Electrical Connections	Check for open phase	
	Motor overloaded	Adjust or replace hydraulic valves	
	Low motor voltage	Verify voltage at motor	
	Open circuit	Check fuses, overload relay, stator and switches	
Motor runs and then slows/stops	Power failure	Verify wiring connections/tighten	
Motor overheats	Overload	Adjust or replace hydraulic valves	
Motor overheats while under load	Motor vents clogged	Check vents - remove cover and clean as necessary	
	Motor connections	Verify all three (3) phases have equal voltage	
	Enclosure terminals	Verify all three (3) phases have equal voltage	
Motor vibrates after corrections	Pump mounting housing bolts	Tighten	
	Motor connections	Verify all three (3) phases have equal voltage	
	Coupling damaged	Remove and examine coupling, replace if needed	
Wrong Rotation	Phases not correct	Reverse any two connections at the contactor	
Unbalanced line current	Unequal terminal voltage	Verify leads and connections	
	Single phase	Check for open contacts	
Motor does not accelerate properly	Low motor voltage	Verify voltage at motor	
	Overload	Adjust or replace hydraulic valves	

Table 15 continued

STORAGE AND TRANSPORTATION

- Unpainted surfaces should be coated with rust preventing agent
- Prevent excessive exposure to water and moisture
- Clean the tool after use - steam clean as needed; remove mud, debris and any other substances
- For long term storage, depressurize the system and flush hydraulic fluid

PARTS LIST

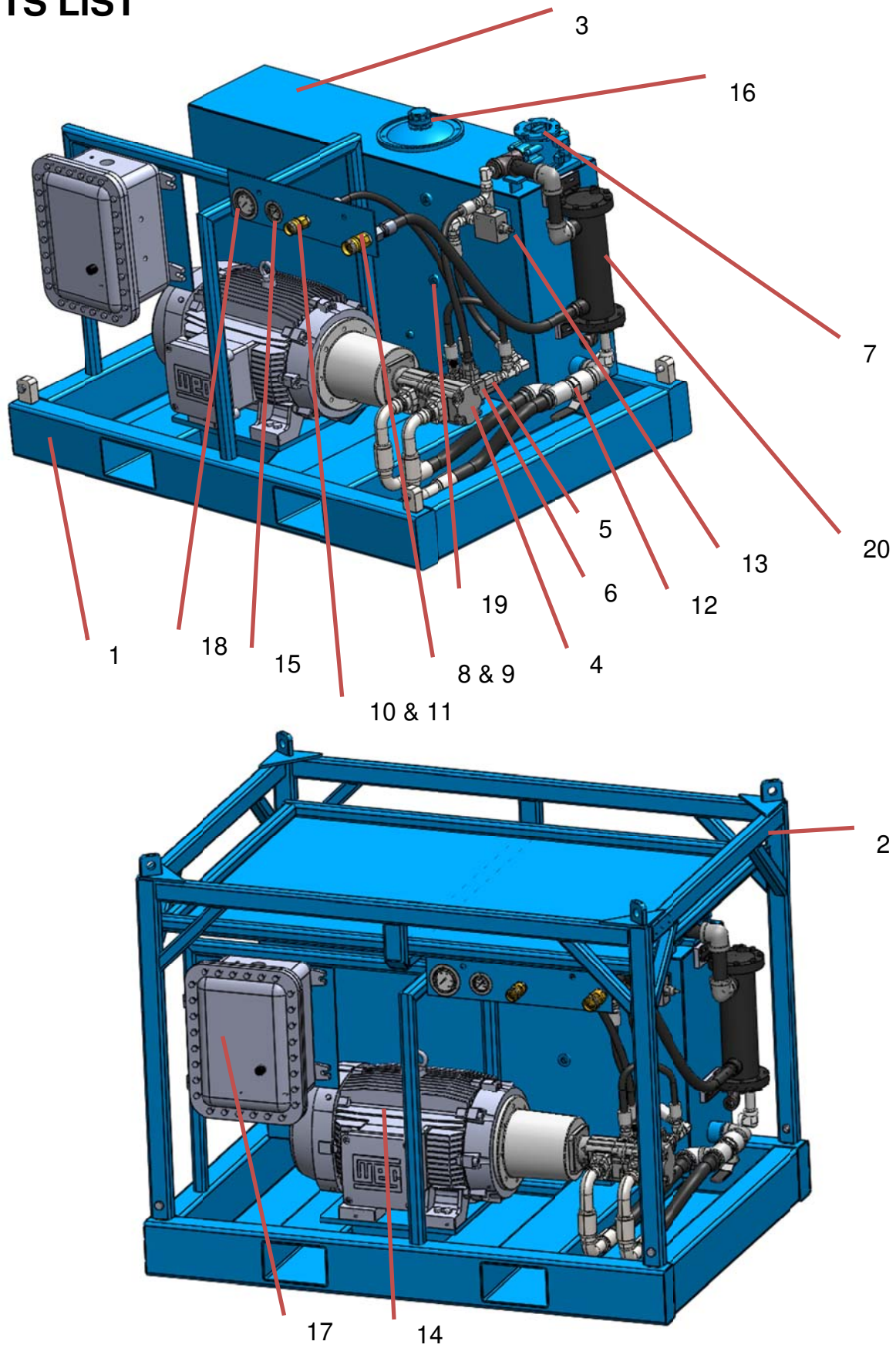

Figure 7 – Electrohydraulic power unit

ASSEMBLY P/N		T1136E-50	T1136E-60
#	Component	Qty	P/N
1	SKID	1	T1136E-1
2	BASKET	1	T1136E-2
3	TANK, HYDRAULIC	1	T1136E-3
4	PUMP	1	060023
5	VALVE, CHECK INLINE	1	060024
6	VALVE, UNLOADING	1	060025
7	RETURN FILTER - RFP	1	060017
8	FEMALE QUICK DISCONNECT RETURN	1	030061
9	RETURN CAP	1	030060
10	FEMALE QUICK DISCONNECT PRESSURE	1	030062
11	PRESSURE CAP	1	030063
12	BALL VALVE, SHUT OFF	1	060020
13	RELIEF VALVE	1	060018
14	MOTOR	1	1136E-50* 1136E-60
15	GAUGE, PRESSURE	1	060012
16	FILLER CAP/FILLER BREATHER	1	T17567-38
17	IEC STARTER STATION	1	n/a 12875E
18	ANALOG PANEL THERMOMETER	1	060064
19	SIGHT GAUGE PLUG	3	060065
20	OIL COOLER	1	060026

*includes starter

Table 16: Figure 7 BOM

SPARE PARTS LIST

Component	Req	P/N
Element for Return Filter	2	060040
Fuses, 13/32" dia x 1-1/2"L, 3-2/10 amp	6	FNM-3-2/10
Fuses, 13/32" dia x 1-1/2"L, 2-1/2 amp	6	FNQ-R-2-1/2

Components for Remote location	Req	P/N
Contactor, Coil Voltage VAC Nom 120V	1	LC1F185
Contactor, Auxiliary 2 pole, 10 amp	1	LA1-DN11
Control Transformer 250VA 2P 380V (50 hz)	1	9070TF250D33
Control Transformer 250VA 2P 460V	1	9070TF250D1
Contact Block 1 NC	1	9001KA3
Contact Block 1 NO	1	9001KA2

Table 17

APPENDIX A



No.:

Date: 11/4/2011

PERFORMANCE CURVES RELATED TO RATED OUTPUT Three-phase induction motor - Squirrel cage rotor

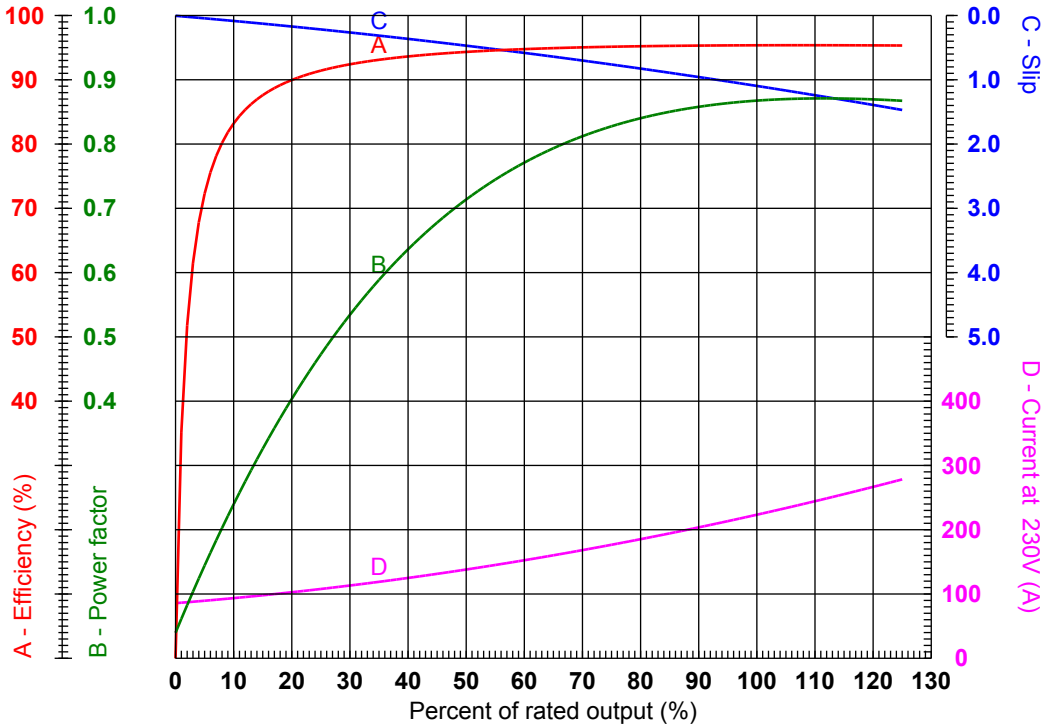

Customer :
 Product line : Three-Phase : Explosion Proof - NEMA Premium

Output : 100 HP	Locked rotor current (I _l /I _n) : 8.7
Frame : 404/5T	Duty cycle : S1
Full load speed : 1780	Service factor : 1.15
Frequency : 60 Hz	Design : B
Voltage : 208-230/460 V	Locked rotor torque : 300 %
Insulation class : F	Breakdown torque : 320 %
Rated current : 250-226/113 A	

Notes:

Performed by: _____ Checked: _____

APPENDIX A



No.:

Date: 11/4/2011

CHARACTERISTIC CURVES RELATED TO SPEED Three-phase induction motor - Squirrel cage rotor

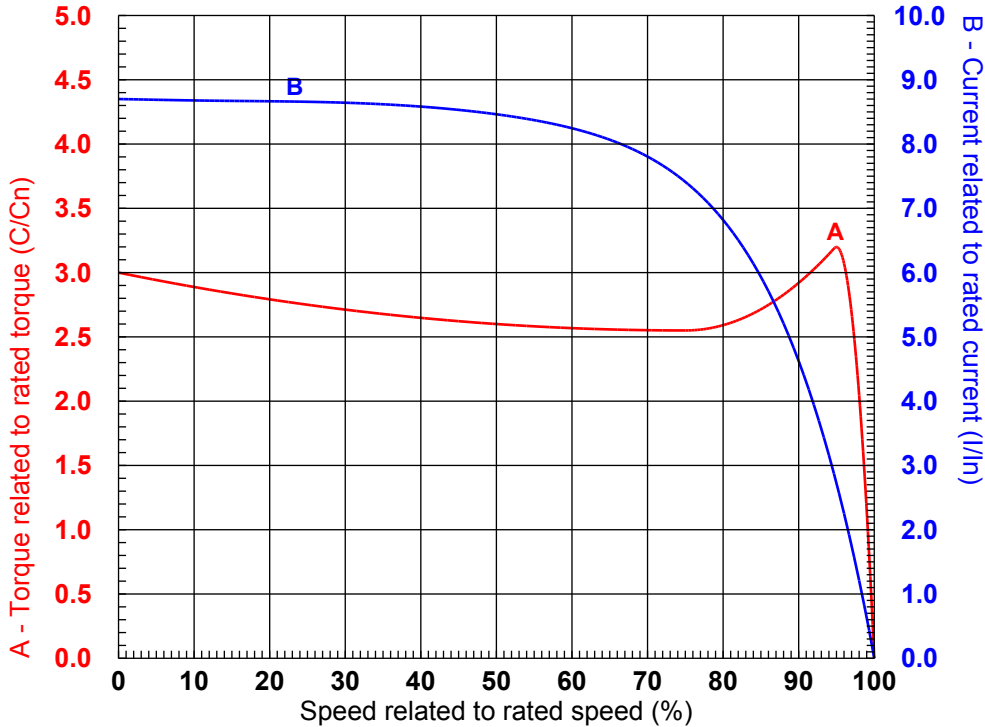

Customer :
Product line : Three-Phase : Explosion Proof - NEMA Premium

Output : 100 HP	Locked rotor current (I _l /I _n) : 8.7
Frame : 404/5T	Duty cycle : S1
Full load speed : 1780	Service factor : 1.15
Frequency : 60 Hz	Design : B
Voltage : 208-230/460 V	Locked rotor torque : 300 %
Insulation class : F	Breakdown torque : 320 %
Rated current : 250-226/113 A	

Notes:

Performed by:	Checked:
---------------	----------

APPENDIX B



No.:

Date: 18-FEB-2015

DATA SHEET

Three-phase induction motor - Squirrel cage rotor

Customer :
 Product line : Three-Phase : Explosion Proof - NEMA Premium

Frame : 404/5T
 Output : 75 HP
 Frequency : 50 Hz
 Poles : 4
 Full load speed : 1480
 Slip : 1.33 %
 Voltage : 380 V
 Rated current : 103 A
 Locked rotor current : 773 A
 Locked rotor current (I_L/I_n) : 7.5
 No-load current : 42.0 A
 Full load torque : 263 lb.ft
 Locked rotor torque : 270 %
 Breakdown torque : 310 %
 Design : A
 Insulation class : F
 Temperature rise : 80 K
 Locked rotor time : 12 s (hot)
 Service factor : 1.00
 Duty cycle : S1
 Ambient temperature : -20°C - +40°C
 Altitude : 1000
 Degree of Protection : IP54
 Approximate weight : 1222 lb
 Moment of inertia : 26.405 sq.ft.lb
 Noise level : 70 dB(A)

	D.E.	N.D.E.	Load	Power factor	Efficiency (%)
Bearings	6217 C3	6314 C3	100%	0.86	94.5
Regreasing interval	9149 h	9789 h	75%	0.80	94.5
Grease amount	21 g	27 g	50%	0.69	94.0

Notes:

Performed by

Checked



No.:

Date: 18-FEB-2015

PERFORMANCE CURVES RELATED TO RATED OUTPUT
Three-phase induction motor - Squirrel cage rotor

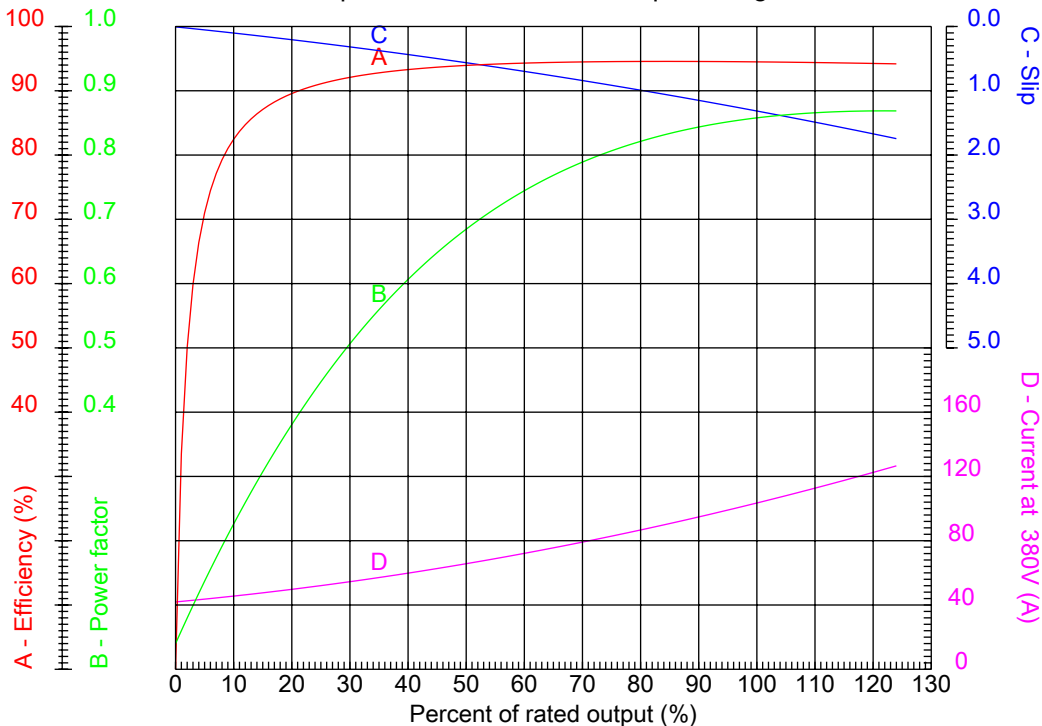

Customer :
 Product line : Three-Phase : Explosion Proof - NEMA Premium

Frame : 404/5T	Locked rotor current (I _l /I _n) : 7.5
Output : 75 HP	Duty cycle : S1
Frequency : 50 Hz	Service factor : 1.00
Full load speed : 1480	Design : A
Voltage : 380 V	Locked rotor torque : 270 %
Rated current : 103 A	Breakdown torque : 310 %
Insulation class : F	

Notes:

Performed by	Checked
--------------	---------



No.:

Date: 18-FEB-2015

CHARACTERISTIC CURVES RELATED TO SPEED
 Three-phase induction motor - Squirrel cage rotor

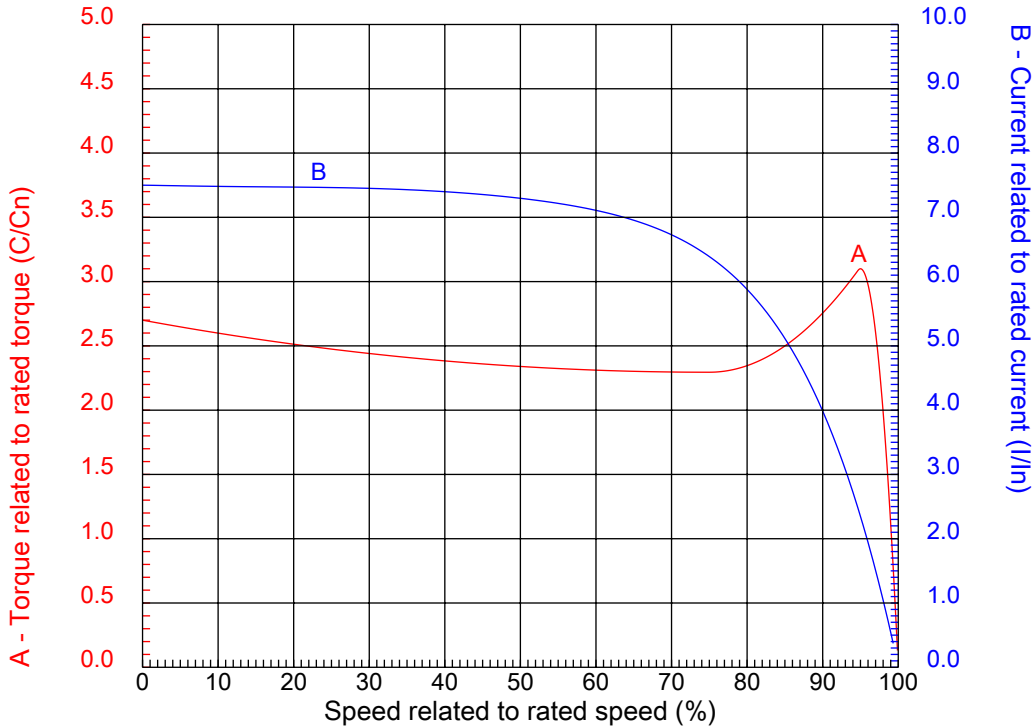

Customer	:	
Product line	:	Three-Phase : Explosion Proof - NEMA Premium

Frame	: 404/5T	Locked rotor current (I _l /I _n)	: 7.5
Output	: 75 HP	Duty cycle	: S1
Frequency	: 50 Hz	Service factor	: 1.00
Full load speed	: 1480	Design	: A
Voltage	: 380 V	Locked rotor torque	: 270 %
Rated current	: 103 A	Breakdown torque	: 310 %
Insulation class	: F		

Notes:

Performed by	Checked
--------------	---------



TOTAL SYSTEMS SOLUTIONS WORLDWIDE™

APPENDIX C



**P30/31™, P50/
51™, P75/76™
Series Single
and Multiple
Pumps and
Motors**

*Pressure to 3000 PSI/175
BAR*

*Output to 120 GPM/
454 LPM*

Motors up to 135 HP

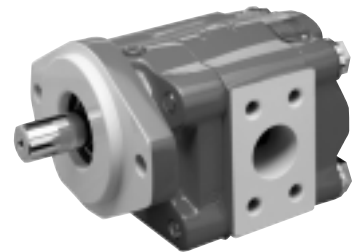

Contents

Average Output Flow - Pumps	4
Average Input Power - Pumps	5
PL Factor	5
Average Performance Data - Motors 30/50/75	6
Average Performance Data - Motors 31/51/76	8
Dimensional Data	10
Approximate Weight	10
30/31 Series Coding	12
50/51 Series Coding	18
75/76 Series Coding	23

Average Output Flow - Pumps

Flow data at 2500 PSI (172 bar) unless noted.

P30/31

Speed RPM	Gear Width Inches				
	1"	1 1/4"	1 1/2"	1 3/4"	2"
900	6.5	8	10	12	13.5
	24.5	30	38	45.5	51
1200	9	11.5	14	16	18.5
	34	43.5	53	60.5	70
1500	11.5	14.5	17.5	20.5	23.5
	43.5	55	66	77.5	89
1800	14	18	21.5	25	29
	53	68	81.5	94.5	110
2100	16.5	21	25	29.5	34
	62.5	79.5	94.5	112	129
2400	19	24	29	34	39
	72	91	110	129	148

gpm/lpm

P50/51

Speed RPM	Gear Width Inches							
	1"	1 1/4"	1 1/2"	1 3/4"	2"	2 1/4"	2 1/2"	
900	8.5	10.5	13	15	17.5	20	22	
	32	39.5	49	57	66	75.5	83.5	
1200	12	15	18	21	24	27	30	
	45.5	57	68	79.5	91	102	114	
1500	15	19	23	27	31	35	39	
	57	72	87	102	117	132	148	
1800	18	23	27.5	32.5	37.5	42	47	
	68	87	104	123	142	159	178	
2100	21.5	27	32.5	38.5	44	49.5	55	
	81.5	102	123	146	167	187	208	
2400	25	31	37	44	51	57	63.5	
	94.5	117	140	167	193	216	240	

gpm/lpm

P75/76

Speed RPM	Gear Width Inches								
	1"	1 1/4"	1 1/2"	1 3/4"	2"	2 1/4"	2 1/2"	2 3/4***	3***
900	11.5	15.5	19.5	23	27	30.5	34.5	38	42
	43.5	58.5	74	87	102	115.5	130.5	144	159
1200	17	22	27	32	37.5	42	48	52.5	58
	64.5	83.5	102	121	142	159	182	199	220
1500	22	29	35.5	41.5	48	54.5	61	67	74
	83.5	110	134	157	182	206	231	254	280
1800	27.5	35.5	43.5	51	59	66	74	81.5	90
	104	134	165	193	223	250	280	308	341
2100	33	42	51.5	60	69.5	78	87	96.5	106
	125	159	195	227	263	295	329	365	401
2400	38	49	59.5	70	80	90	101	111	122
	144	185	225	265	303	341	382	420	462

gpm/lpm

* Flow data at 2000 PSI (138 bar) rated pressure.

Average Input Power - Pumps

Power data at 2500 PSI (172 bar) unless noted.

P30/31

Speed RPM	Gear Width Inches				
	1"	1 1/4"	1 1/2"	1 3/4"	2"
900	14	17	20	23	25
	11	13	15	17	19
1200	19	22	26	30	33
	14	17	20	22	25
1500	23	28	33	37	42
	17	21	24	27	31
1800	27	33	39	44	50
	20	25	29	33	37
2100	32	38	45	51	58
	24	29	34	38	43
2400	36	44	51	58	66
	26	33	38	43	49

HP/kW

P50/51

Speed RPM	Gear Width Inches							
	1"	1 1/4"	1 1/2"	1 3/4"	2"	2 1/4"	2 1/2"	
900	19	22	26	30	34	38	42	
	14	17	20	23	26	29	32	
1200	25	30	34	40	45	51	56	
	18	22	26	30	34	38	42	
1500	31	37	43	50	56	63	69	
	23	27	32	37	42	47	51	
1800	36	44	51	59	67	75	82	
	27	33	38	44	50	56	61	
2100	42	51	60	69	78	87	96	
	31	38	44	51	58	65	72	
2400	47	57	68	79	89	99	110	
	35	43	51	59	66	74	82	

HP/kW

Shaft Style	PL Chart	
	Integral Shaft & Gear	Two Piece Style
30/31		
SAE "A" Spline	2,600	2,600
SAE "B" Spline	7,900	5,850
SAE "B" Key	4,850	4,850
SAE "BB" Spline	12,150	--
SAE "BB" Key	7,250	5,850
SAE "C" Spline	--	5,850
Connecting Shaft	--	5,850
50/51		
SAE "B" Spline	6,100	6,100
SAE "B-B" Spline	9,400	--
SAE "B-B" Key	5,600	5,600
SAE "C" Spline	12,900	8,500
SAE "C" Key	10,900	8,500
Connecting Shaft	--	8,500
75/76		
SAE "C" Single	8,000	8,000
SAE "C" Tandem	12,500	--
SAE "C" Key	7,500	7,500
Connecting Shaft	--	10,000

PL FACTOR

Each section of a multiple pump or motor should be regarded as a single unit with corresponding delivery and power input requirements. Since the entire input horsepower is fed through a common drive shaft, the power delivered to or from the unit is limited by the physical strength of the shaft. This limit is defined as a "PL" factor; "P" being the operating pressure and "L" the summation of gear widths.

In multiple units the "PL" must be calculated for the first connecting shaft as well as the drive shaft. Each style or type of shaft has a unique "PL" factor as noted in the table below.

Pressure X Total Gear Width = PL
 PL MUST NOT EXCEED NUMBER SHOWN IN CHART FOR APPROPRIATE SHAFT.

P75/76

Speed RPM	Gear Width Inches								
	1"	1 1/4"	1 1/2"	1 3/4"	2"	2 1/4"	2 1/2"	2 3/4"*	3"*
900	26	32	39	45	51	58	64	57	62
	19	24	29	34	38	43	48	42	46
1200	35	43	52	60	69	78	86	76	83
	26	32	39	45	51	58	64	57	62
1500	44	55	65	76	87	98	109	96	105
	33	41	49	57	65	73	81	72	78
1800	53	66	79	93	106	119	132	116	127
	39	49	59	69	79	89	99	87	95
2100	62	77	93	108	124	139	154	136	148
	46	58	69	81	92	104	115	101	111
2400	71	88	106	124	141	159	176	155	169
	53	66	79	92	105	118	132	116	126

HP/kW

* Input data at 2000 PSI (138 bar) rated pressure.

Average Performance Data - Motors

Motor performance data at 2000 PSI (138 bar).

M30

Speed RPM	1" Gear			1 1/2" Gear			2" Gear		
	Output		Input	Output		Input	Output		Input
	Torque	Power	Flow	Torque	Power	Flow	Torque	Power	Flow
800	550	7	9	870	11	13	1150	14.5	17
	62	5	34	98.5	8	49	130	11	64.5
1200	550	10.5	13	870	16.5	18	1150	22	23.5
	62	8	49	98.5	12.5	68	130	16.5	89
1600	550	14	16	860	22	23	1140	29	30.5
	62	10.5	60.5	97	16.5	87	129	21.5	115
2000	550	17.5	19.5	850	27	28	1125	36	37
	62	13	74	96	20	106	127	27	140

U.S./Metric Torque: In.-lbs. / Nm Flow: GPM / LPM Power: HP / kW

M50

Speed RPM	1" Gear			1 1/2" Gear			2" Gear		
	Output		Input	Output		Input	Output		Input
	Torque	Power	Flow	Torque	Power	Flow	Torque	Power	Flow
800	670	8.5	10.5	1070	13.5	15.5	1450	18	21
	75.5	6.5	39.5	121	10	58.5	164	13.5	79.5
1200	680	13	15.5	1075	20.5	22.5	1450	27.5	30.5
	77	9.5	58.5	121.5	15	85	164	20.5	115
1600	670	17	20	1045	26.5	30	1440	36.5	40
	75.5	12.5	75.5	118	20	114	162.5	27	151
2000	660	21	25	1030	32.5	37	1415	44.5	49
	74.5	15.5	94.5	116.5	24	140	160	33	185

U.S./Metric Torque: In.-lbs. / Nm Flow: GPM / LPM Power: HP / kW

M75

Speed RPM	1" Gear			1 1/2" Gear			2" Gear		
	Output		Input	Output		Input	Output		Input
	Torque	Power	Flow	Torque	Power	Flow	Torque	Power	Flow
800	1050	13.5	20.5	1650	21	28	2200	28	35.5
	118.5	10	77.5	186.5	15.5	106	248.5	21	134
1200	1025	19.5	27.5	1600	30.5	38	2200	42	49.5
	116	14.5	104	181	22.5	144	248.5	31.5	187
1600	1000	25.5	34	1575	40	49	2175	55	64
	113	19	129	178	30	185	245.5	41	242
2000	950	30	41.5	1550	49	59	2175	67.5	78
	107.5	22.5	157	175	36.5	223	245.5	50.5	295

U.S./Metric Torque: In.-lbs. / Nm Flow: GPM / LPM Power: HP / kW

M50 (continued)

Speed RPM	2 1/2" Gear		
	Output		Input
	Torque	Power	Flow
800	1850	23.5	26
	209	17.5	98.5
1200	1840	35	37.5
	208	26	142
1600	1750	44.5	49.5
	197.5	33	187
2000	1720	54.5	61.5
	194.5	40.5	233

M75 (continued)

Speed RPM	2 1/2" Gear			3" Gear		
	Output		Input	Output		Input
	Torque	Power	Flow	Torque	Power	Flow
800	2875	36.5	43	3625	46	50.5
	325	27	163	409.5	34.5	191
1200	2850	54	60.5	3575	68	72
	322	40.5	229	404	50.5	273
1600	2800	71	78.5	3500	89	93
	316.5	53	297	395.5	66.5	352
2000	2750	87	96.5	3425	109	114
	310.5	65	365	387	81.5	431

Average Performance Data - Motors

Motor performance data at 2500 PSI (172 bar) unless noted.

M31

Speed RPM	1" Gear			1 1/2" Gear			2" Gear		
	Output		Input	Output		Input	Output		Input
	Torque	Power	Flow	Torque	Power	Flow	Torque	Power	Flow
800	675	8.5	9	1035	13	13	1385	17.5	17
	76.5	6.5	34	117	9.5	49	156.5	13	64.5
1200	685	13	13	1055	20	18	1410	27	23.5
	77.5	9.5	49	119	15	68	159.5	20	89
1600	680	17.5	16	1030	26	23	1390	35	30.5
	77	13	60.5	116.5	19.5	87	157	26	115
2000	660	21	19.5	1010	32	28	1370	43.5	37
	74.5	15.5	74	114	24	106	155	32.5	140

U.S./Metric Torque: In.-lbs. Flow: GPM Power: HP
Nm LPM kW

M51

Speed RPM	1" Gear			1 1/2" Gear			2" Gear		
	Output		Input	Output		Input	Output		Input
	Torque	Power	Flow	Torque	Power	Flow	Torque	Power	Flow
800	825	10.5	10.5	1310	16.5	15.5	1810	23	21
	93	8	39.5	148	12.5	58.5	204.5	17	79.5
1200	850	16	15.5	1340	25.5	22.5	1830	35	30.5
	96	12	58.5	151.5	19	85	207	26	115
1600	830	21	20	1330	34	30	1805	46	40
	94	15.5	75.5	150.5	25.5	114	204	34.5	151
2000	800	25.5	25	1290	41	37	1770	56	49
	90.5	19	94.5	146	30.5	140	200	42	185

U.S./Metric Torque: In.-lbs. Flow: GPM Power: HP
Nm LPM kW

M76

Speed RPM	1" Gear			1 1/2" Gear			2" Gear		
	Output		Input	Output		Input	Output		Input
	Torque	Power	Flow	Torque	Power	Flow	Torque	Power	Flow
800	1410	18	20.5	2140	27	28	2875	36.5	35.5
	159.5	13.5	77.5	242	20	106	325	27	134
1200	1400	26.5	27.5	2140	41	38	2870	54.5	49.5
	158	20	104	242	30.5	144	324.5	40.5	187
1600	1375	35	34	2110	53.5	49	2830	72	64
	155.5	26	129	238.5	40	185	319.5	53.5	242
2000	1350	43	41.5	2090	66.5	59	2800	89	78
	152.5	32	157	236	49.5	223	316.5	66.5	295

U.S./Metric Torque: In.-lbs. Flow: GPM Power: HP
Nm LPM kW

M51 (continued)

Speed RPM	2 1/2" Gear		
	Output		Input
	Torque	Power	Flow
800	2330	29.5	26
	263.5	22	98.5
1200	2340	44.5	37.5
	264.5	33	142
1600	2300	58.5	49.5
	260	43.5	187
2000	2250	71.5	61.5
	254	53.5	233

M76 (continued)

Speed RPM	2 1/2" Gear			3" Gear*		
	Output		Input	Output		Input
	Torque	Power	Flow	Torque	Power	Flow
800	3650	46.5	43	3625	46	50.5
	412.5	34.6	163	409.5	34.5	191
1200	3650	69.5	60.5	3575	68	72
	412.5	52	229	404	50.5	273
1600	3600	91.5	78.5	3500	89	93
	406.5	68	297	395.5	66.5	352
2000	3500	111	96.5	3425	109	114
	395.5	83	365	387	81.5	431

* Motor performance data at 2000 PSI (138 bar) rated pressure.

Dimensional Data

Model		A ⁽¹⁾	Bs ⁽²⁾⁽³⁾	Bm ⁽³⁾⁽⁴⁾	C ⁽⁵⁾⁽⁶⁾	D ⁽⁵⁾⁽⁷⁾	E ⁽³⁾	F ⁽²⁾	G	H	I	J	K
P30/31	in.	1.62	5.44	8.69	5.44	5.88	2.94	0.75	1.75	2.50	0.88	2.69	5.38
	mm.	41.3	138.1	220.7	138.1	149.2	74.6	19.1	44.5	63.5	22.2	68.3	136.5
P50/51	in.	2.19	5.88	9.50	5.44	5.88	3.38	0.75	1.75	2.88	1.00	3.00	6.00
	mm.	55.6	149.2	241.3	138.1	149.2	85.7	19.1	44.5	73.0	25.4	76.2	152.4
P75/76	in.	2.19	6.75	10.75	7.75	7.94	3.75	1.00	2.00	3.00	1.25	3.94	7.88
	mm.	55.6	171.5	273.1	196.9	201.6	95.3	25.4	50.8	76.2	31.8	100.0	200.0

U.S./Metric

NOTES

1. Dimension will vary with shaft type
2. Dimension + gear width
3. Dimension is for Type 1 SEC. For Type 2: subtract 1.12" (28.4 mm) for 30/31; subtract 1.00" (25.4 mm) for 50/51.
4. Dimension + total gear width
5. Dimension will vary with port type. Subtract 0.25" (6.4 mm) for S.F. ports.
6. For 2.25" and 2.50" gear width in 50/51 series, dimension is 6.75" (171.5 mm).
7. Dimension is for wide B-C. Narrow B-C dimensions: 5.00" (127 mm) for 30/31 and 50/51; 7.19" (182.6 mm) for 75/76.
8. Dimension + 1/2 front section gear width

Model		L ⁽³⁾⁽⁸⁾	M ⁽⁴⁾
P30/31	in.	3.31	3.25
	mm.	84.1	82.6
P50/51	in.	3.75	3.62
	mm.	95.3	92.1
P75/76	in.	4.75	4.00
	mm.	120.7	101.6

Approximate Weight

Single Unit

Model	Unit Weight	1"	1 1/4"	1 1/2"	1 3/4"	2"	2 1/4"	2 1/2"	2 3/4"	3"
P30/31	Pounds	33	34	35	36	37	-	-	-	-
	KG	15	15.5	16	16.5	17	-	-	-	-
P50/51	Pounds	37	38.5	40	41.5	43	48.5	50	-	-
	KG	17	17.5	18	19	19.5	22	22.5	-	-
P75/76	Pounds	72	75	77	80	82	85	87	90	92
	KG	33	34	35	36	37	39	40	41	42

Approximate Weight

Multiple Unit*

Model	Add per gear section	1"	1 1/4"	1 1/2"	1 3/4"	2"	2 1/4"	2 1/2"	2 3/4"	3"
P30/31	Pounds	27	28	29	31	32	-	-	-	-
	KG	12	12.5	13	14	14.5	-	-	-	-
P50/51	Pounds	31	32.5	34	35.5	37	42.5	44	-	-
	KG	14	15	15.5	16	17	19	20	-	-
P75/76	Pounds	59	62	64	67	69	72	74	77	79
	KG	27	28	29	31	32	33	34	35	36

*Determine the approximate weight from Single Unit chart and add weight of each additional assembly from this chart.

Dimensional Data

Single Unit - P30/31/50/51

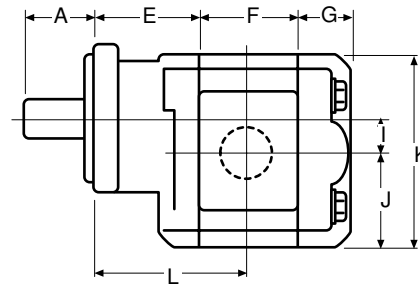
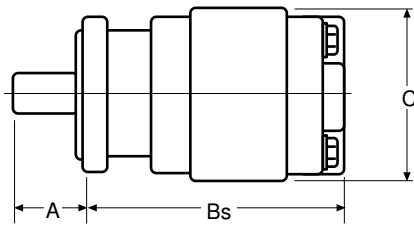

Single Unit - P75/76

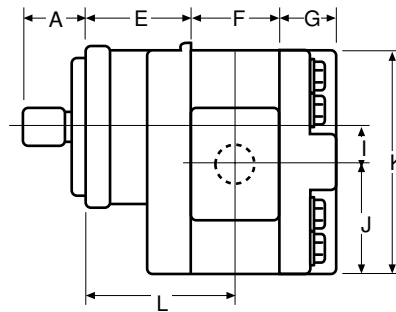
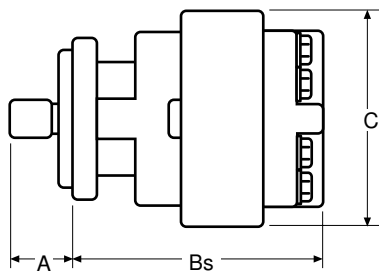

Multiple Unit - P30/31/50/51

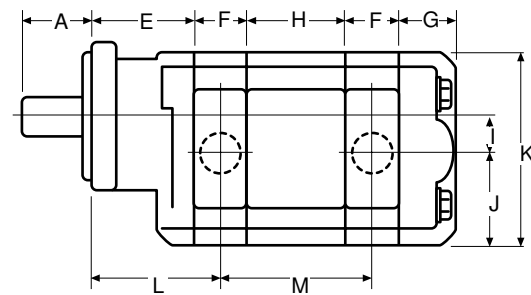
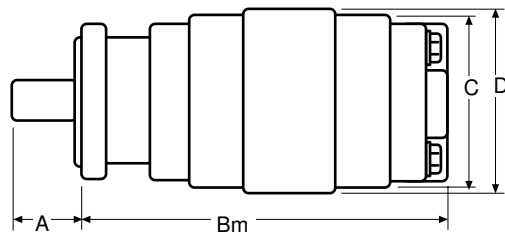

Multiple Unit - P75/76

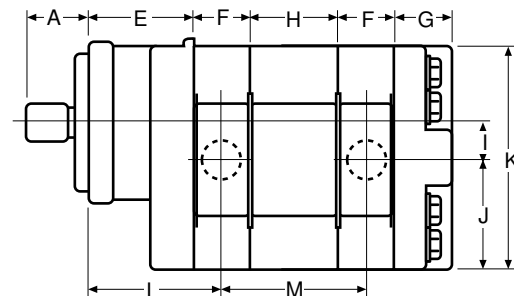
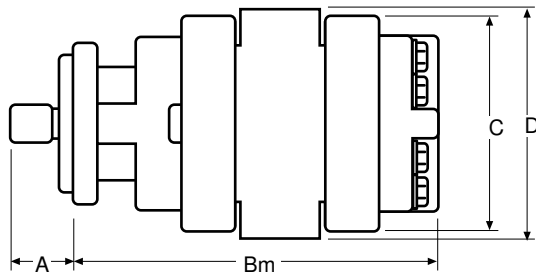

30/31 Series Coding

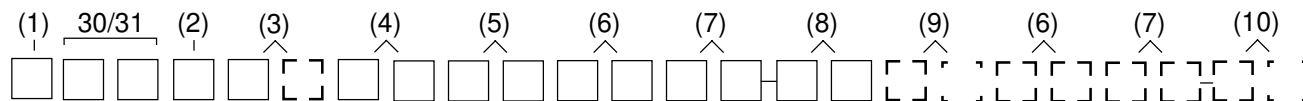

Pump/Motor (1)

P	Pump
M	Motor

Unit (2)

A	Single Unit
B	Tandem Unit
C	Single or Tandem w. two-piece shaft (O.B. bearing required)

Shaft End Cover (3)

1	Pump, cw w/o O.B. bearing
2	Pump, ccw w/o O.B. bearing
3	Pump, bi-rotational w/o O.B. bearing (30 series only)
4	Pump, cw with O.B. bearing
5	Pump, ccw with O.B. bearing
6	Pump, bi-rotational with O.B. bearing (30 series only)
8	Motor, bi-rot. with O.B. bearing + 1/4" NPT drain
9	Motor, bi-rot. w/o O.B. bearing + 1/4" NPT drain
18	Motor, bi-rot. with O.B. bearing + 1/4" BSPP drain
19	Motor, bi-rot. w/o O.B. bearing + 1/4" BSPP drain

Shaft End Cover (4) (type 1 unless noted)

00	Pad mount
05	6 bolt flange - 3.25" dia. bolt circle
42	SAE 4 bolt "B" ANSI 101-4
78	SAE 4 bolt "C" ANSI 127-4
91	30-30, 31-31, & 50-30, 51-31 for piggyback
92	75-30, 76-31 for piggyback
94	SAE 2 bolt "A" ANSI 82-2
96	SAE 2 bolt "B" ANSI 101-2, type 2 (not available with O.B. bearing)
97	SAE 2 bolt "B" ANSI 101-2

Port End Cover (5) (Rear Ported)

Left	Right	Single	Tandem	Extended Studs
Unported				
-	-	BE	BI	BY

NPT Porting (30 series only)

3/4"	-	KE	KI	KY
-	3/4"	LE	LI	LY
3/4"	3/4"	ME	MI	MY

NPT Porting (30 series only) - Modified Casting*

1"	1"	QU	QU	-
----	----	-----------	-----------	---

* Modified PEC casting is for higher pressure/larger port applications.

Port End Cover (5) (Rear Ported) continued

Left	Right	Single	Tandem	Extended Studs
O.D.T. Porting				
3/4"	-	CE	CI	CY
-	3/4"	DE	DI	DY
3/4"	3/4"	FE	FI	FY
1"	3/4"	GE	GI	GY
3/4"	1"	HE	HI	HY

O.D. Tube Porting (30 series only)

1"	1"	JE	JI	JY
----	----	-----------	-----------	-----------

O.D. Tube Porting - Modified Casting*

3/4"	-	CA	CU	CO
-	3/4"	DA	DU	DO
3/4"	3/4"	JA	JU	BO
1"	3/4"	KA	KU	-
3/4"	1"	LA	LU	-
1"	-	MA	MU	YO
-	1"	RA	SU	RO
1"	1"	ZA	ZU	ZO
1 1/4"	1"	GU	GU	-
1"	1 1/4"	HU	HU	-

BSPP Porting

3/4"	-	WE	WI	WY
-	3/4"	XE	XI	XY
3/4"	3/4"	ZE	ZI	ZY

Metric Straight Thread

3/4"	-	NE	NI	NY
-	3/4"	PE	PI	PY
3/4"	3/4"	QE	QI	QY
1"	3/4"	RE	RI	RY
3/4"	1"	SE	SI	SY

Port End Cover (5) (Side Ported)

Left	Right	Single	Tandem	Extended Studs
O.D. Tube Porting - Modified Casting*				
1 1/4"	1"	TU	TU	-
1"	1 1/4"	XU	XU	-

CW | **CCW** | **Double**
| | |

Piggyback Port End - Pump Only

Type 30-30, 31-31 (double 30-30 only)	KO	LO	MO
---------------------------------------	-----------	-----------	-----------

For All Units

To determine direction of shaft rotation, view the unit with the shaft pointing toward you, and the idler (driven) gear beneath the shaft. With clockwise rotation, flow will be left to right. The pump inlet port will be on the left, outlet on the right. The flow is in the opposite direction with counter-clockwise rotation. Inverting the pump will reverse the inlet and outlet ports but not the direction of rotation.

Gear Housing (6)

Series	30	30	30	30	30	30	31	31	31	31	31
Housing Code	07	10	12	15	17	20	10	12	15	17	20
Displacement (C.I.R.)	1.48	1.97	2.46	2.96	3.45	3.94	1.97	2.46	2.96	3.45	3.94
Maximum (PSI)	2500	2500	2500	2500	2250	2250	3000	3000	3000	2500	2500
IN	OUT	CW	CCW								
-	-	AB	AB	X	X	X	X	X	X	X	X
No Porting											
NPT Porting											
1/2"	-	IL	IM	X	X						
-	1/2"	IM	IL	X	X						
1/2"	1/2"	IR	IR	X							
3/4"	-	IC	ID		X	X	X	X	X		
-	3/4"	ID	IC		X	X	X	X	X		
3/4"	3/4"	IF	IF		X	X	X	X	X		
1"	3/4"	IJ	IG		X*	X	X	X			
1 1/4"	3/4"	IK	IH				X*	X			
1"	-	YC	YD		X*	X	X	X			
-	1"	YD	YC			X	X	X			
1"	1"	YF	YF			X	X	X	X		
1 1/4"	1"	YJ	YG				X*	X	X		
1 1/4"	-	IA	IB				X*	X	X		
-	1 1/4"	IB	IA					X	X		
1 1/4"	1 1/4"	YL	YL					X	X		
1 1/2"	-	YA	YB							X*	
1 1/2"	1 1/4"	YP	YM							X*	
OD Tube Porting											
3/4"	-	EC	ED		2000	X	X	X		X*	X
-	3/4"	ED	EC		2000	X	X	X		X	X
3/4"	3/4"	EF	EF		2000	X	X	X	X	X	X
1"	3/4"	EJ	EG		2000*	X*	X	X	X	X*	X*
1 1/4"	3/4"	EK	EH				X*	X*		X*	X*
1 1/2"	3/4"	IP	IN					X*	X*		X*
7/8"	-	EZ	-			X					
-	7/8"	-	EZ			X					
1"	7/8"	EM	EL			X*					
1"	-	AC	AD		X*	2000	X	X	X	X*	X*
-	1"	AD	AC			2000	X	X	X		2500
1"	1"	AF	AF				X	X	X		2500
1 1/4"	1"	AJ	AG				X*	X*	X		2500*
1 1/2"	1"	AK	AH					X*	X*		X*
1 1/4"	-	AA	AO				X*	2000			X*
-	1 1/4"	AO	AA					2000			X*
1 1/4"	1 1/4"	AL	AL					2000	X		X
1 1/2"	1 1/4"	AP	AM					2000*	X*		X*
1 1/2"	-	AE	AU					X*	2000		X*
-	1 1/2"	AU	AE						2000		

NOTES

Shaded cells are acceptable for motor codes.

* This porting is acceptable for low pressure inlet port only.

NPT ports are not recommended for use at pressures in excess of 1500 PSI.

"X" Means both codes are available.

"2000" or "2500" indicates maximum pressure rating on port.

Gear Housing (6) *continued*

Series	30	30	30	30	30	30	31	31	31	31	31
Housing Code	07	10	12	15	17	20	10	12	15	17	20
Displacement (C.I.R.)	1.48	1.97	2.46	2.96	3.45	3.94	1.97	2.46	2.96	3.45	3.94
Maximum (PSI)	2500	2500	2500	2500	2250	2250	3000	3000	3000	2500	2500
IN	OUT	CW	CCW								
Split Flange Porting											
3/4"	-	UC	UD	X	X	UD	X	X	X	X	X
-	3/4"	UD	UC	X	X	UD	X	X	X	X	X
3/4"	3/4"	UF	UF	X	X	X	X	X	X	X	X
1"	3/4"	UJ	UG	X	X	UJ	UJ	X	X	X	X
1 1/4"	3/4"	UK	UH	X	X	X	X	X	X	X	X
1"	-	OC	OD	X	X	X	OD	2500	X	X	X
-	1"	OD	OC	X	X	X	OD	2500	X	X	X
1"	1"	OF	OF	X	X	X	X	2500	X	X	X
1 1/4"	1"	OJ	OG	X	X	X	X	X	X	X	X
1 1/2"	1"	OK	OH	X	X	X	X	X	X	X	X
1 1/4"	-	OA	OB	2000	X	X	X	X	X	X	X
-	1 1/4"	OB	OA	2000	X	X	X	X	X	X	X
1 1/4"	1 1/4"	OL	OL	X	X	X	X	X	X	X	X
1 1/2"	1 1/4"	OP	OM	X	X	X	X	X	X	X	X
1 1/2"	-	OE	OU	2000	X	X	X	X	X	X	X
-	1 1/2"	OU	OE	2000	X	X	X	X	X	X	X
BSPP Porting											
3/4"	-	YN	YQ	X	X	X	X	2500	X	X	YQ
-	3/4"	YQ	YN	X	X	X	X	2500	X	X	YQ
3/4"	3/4"	YS	YS	X	X	X	X	2500	X	X	X
1"	3/4"	YV	YT	X	X	YV	YV	2500*	X	YV*	X
1 1/4"	3/4"	YW	YU	X	X	X	X	X	X	YU*	X*
1"	-	SL	RQ	2000	X	X	X	SL*	2500	X	X
-	1"	RQ	SL	2000	X	X	X	X	2500	X	X
1"	1"	MP	MP	2000	X	X	X	X	X	X	X
1 1/4"	1"	IX	VY	X	X	X	X	X	2500*	X*	X
1 1/4"	-	NJ	UI	2000	X	X	X	X	X	X	X
-	1 1/4"	UI	NJ	2000	X	X	X	X	X	X	X
1 1/4"	1 1/4"	PF	PF	2000	X	X	X	X	X	X	X
1 1/2"	1"	VI	HW	X	X	X	X	X	X	X	X
Metric Straight Thread Porting											
3/4"	-	EN	TQ	X	X	TQ	TQ	2500	X	X	X
-	3/4"	TQ	EN	X	X	TQ	TQ	2500	X	X	X
3/4"	3/4"	ES	ES	X	X	X	X	2500	X	X	X
1"	3/4"	EV	ET	X	X	EV	EV	X	X	X	X
1 1/4"	3/4"	EW	EU	X	X	X	X	X	X	X	X
1"	-	NL	ER	X	X	ER	ER	2500	X	X	X
-	1"	ER	NL	X	X	ER	ER	2500	X	X	X
1"	1"	CM	CM	2000	X	X	X	2500	X	X	X
1 1/4"	1"	EX	VE	X	X	X	X	2500*	X	X	X
1 1/2"	1"	VA	HA	X	X	X	X	X	X	X	X
1 1/4"	1 1/4"	PA	PA	2000	X	X	X	X	X	X	X
1 1/2"	1 1/4"	SA	QA	X	X	X	X	X	X	X	X

NOTES

Shaded cells are acceptable for motor codes.

* This porting is acceptable for low pressure inlet port only.

"X" Means both codes are available.

"2000" or "2500" indicates maximum pressure rating on port.

Gear Housing (6) *continued*

Series	30	30	30	30	30	30	31	31	31	31	31
Housing Code	07	10	12	15	17	20	10	12	15	17	20
Displacement (C.I.R.)	1.48	1.97	2.46	2.96	3.45	3.94	1.97	2.46	2.96	3.45	3.94
Maximum (PSI)	2500	2500	2500	2500	2250	2250	3000	3000	3000	2500	2500
IN	OUT	CW	CCW								
							Metric Straight Thread Porting				
3/4"	-	VN	VQ	X	X	X	X	X			X
-	3/4"	VQ	VN	X	X	X	X	X			X
3/4"	3/4"	VS	VS	X	X						X
1"	3/4"	RV	VT	X	X	X	X		X*	X	
1 1/4"	3/4"	RW	RU		X*		X		X*	X*	
1"	-	UL	UR	X	X	X	X	X	2500	X	X
-	1"	UR	UL	X	X	X	X	X	2500	X	X
1"	1"	UM	UM		X	X	X		X	X	X
1 1/4"	1"	UX	VU		X*	X	X	X	X*	X*	X
1 1/2"	1"	VO	HO				X*	X		X*	X*
1 1/4"	-	NO	UO			X		X	X*	2500	
-	1 1/4"	UO	NO			X		X	X*	2500	
1 1/4"	1 1/4"	PO	PO			X	X	X			X
1 1/2"	1 1/4"	SO	QO				X*	X		X*	X*
1 1/2"	-	UY	TO			X*	2000			X*	X
-	1 1/2"	TO	UY				2000				X

NOTES:

Shaded cells are acceptable for motor codes.

* This porting is acceptable for low pressure inlet port only.

"X" Means both codes are available.

"2000" or "2500" indicates maximum pressure rating on port.

Gear Width (7)

30 Series

	Gear Width	in. ³ /rev.	cm ³ /rev.	Max Pressure
05	1/2"	0.99	16.1	2500 psi (172 bar)
07	3/4"	1.48	24.2	2500 psi (172 bar)
10	1"	1.97	32.3	2500 psi (172 bar)
12	1 1/4"	2.46	40.4	2500 psi (172 bar)
15	1 1/2"	2.96	48.4	2500 psi (172 bar)
17	1 3/4"	3.45	56.5	2250 psi (155 bar)
20	2"	3.94	64.6	2250 psi (155 bar)

31 Series

	Gear Width	in. ³ /rev.	cm ³ /rev.	Max Pressure
05	1/2"	0.99	16.1	3000 psi (207 bar)
07	3/4"	1.48	24.2	3000 psi (207 bar)
10	1"	1.97	32.3	3000 psi (207 bar)
12	1 1/4"	2.46	40.4	3000 psi (207 bar)
15	1 1/2"	2.96	48.4	3000 psi (207 bar)
17	1 3/4"	3.45	56.5	2500 psi (172 bar)
20	2"	3.94	64.6	2500 psi (172 bar)

Shaft Type (8) (type 1 unless noted)

For single, tandem, or two piece shaft unless noted.

07	SAE "C" 14 tooth spline .125" dia., ANSI 32-4 (two piece only)
12	Keyed shaft .75 dia., .19"X.19"X1.56" key (two piece only)
14	30-30, 31-31 piggyback shaft
22	50-30, 51-31 piggyback shaft
23	75-30, 76-31 piggyback shaft
25	SAE "B" 13 tooth spline .88" dia., ANSI 22-4
30	SAE "B" keyed .88" dia., 1/4"X3/8" X 1" key, ANSI 22-1
32	Clutch pump shaft, tapered & keyed, 1:4 taper (single & two piece), #6 woodruff key
43	SAE "B-B" keyed 1.00" dia. 1/4"X3/8"X1 1/4" key, ANSI 25-1 modified length
65	SAE "B" 13 tooth spline .875" dia., ANSI 22-4, type 2 (single & tandem)
66	SAE "B" keyed .88" dia, 1/4"X3/8"X1" key, type 2 (single & tandem)
67	SAE "B-B" keyed 1.00" dia., 1/4"X3/8"X1 1/4" key, ANSI 25-1 modified length, type 2 (single & tandem)
68	6 tooth spline 1.00" dia.
90	SAE "B" keyed w/ 5/8"-18 thread, .875" dia, ANSI 22-2 modified length (single & tandem)
95	SAE "A" 9 tooth spline, .62" dia. ANSI 16-4 (single only)
98	SAE "B-B" 15 tooth spline, 1.00" dia., ANSI 25-4 (single & tandem)

Bearing Carriers (9) Pump Only

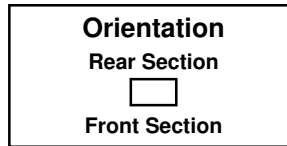

Common Inlet Passage

IN	OUT	CW	CCW
I	I	I	I
-	-	C	D
*	-	A	U

* 31 Series only. Used when only one adjacent gear housing has an inlet port.

NPT Porting (30 Series only)

1"	-	TB	BT
1 1/4"	-	VB	BV
1"	3/4"	TX	XT
1 1/4"	3/4"	VX	XV
1 1/4"	1"	VZ	ZV
1"	3/4"	TJ	JT
1 1/4"	3/4"	VJ	JV
1 1/4"	1"	VK	KV
1 1/2"	1"	KW	-
1"	3/4"	ZX	XZ
1"	3/4"	ZS	SZ

ODT Porting

1"	-	CB	BC
1 1/4"	-	DB	BD
1 1/2"	-	FB	BF
*	3/4"	-	JP
1"	3/4"	CJ	JC
1 1/4"	3/4"	DJ	JD
1 1/2"	3/4"	FJ	JF
1 1/4"	1"	DK	KD
1 1/2"	1"	FK	KF
* 30 Series only.			
1"	3/4"	CR	RC
1 1/4"	3/4"	DR	RD
*1 1/2"	3/4"	FR	RF
1 1/4"	1"	DS	SD
1 1/2"	1"	FS	SF

* 30 Series only.

1"	3/4"	KJ	JK
1"	3/4"	KX	XK

Split Flange Porting

IN	OUT	CW	CCW
I	I	I	I
1"	-	LB	BL
1 1/4"	-	MB	BM
1 1/2"	-	NB	BN
-	3/4"	BR	RB
1"	3/4"	LR	RL
1 1/4"	3/4"	MR	RM
1 1/2"	3/4"	NR	RN
1 1/4"	1"	MS	SM
1 1/2"	1"	NS	SN
1"	3/4"	LX	XL
1 1/4"	3/4"	MX	XM
*1 1/2"	3/4"	NX	XN
1 1/4"	1"	MZ	ZM
1 1/2"	1"	NZ	ZN
* 30 Series only.			
1"	3/4"	SR	RS
1"	3/4"	RZ	ZR

BSPP Porting

1"	-	CX	XC
1 1/4"	-	DX	XD
1 1/2"	-	FX	XF
*	3/4"	-	TL
1"	3/4"	CT	TC
1 1/4"	3/4"	DT	TD
1 1/2"	3/4"	FT	TF
1 1/4"	1"	DV	VD
1 1/2"	1"	FV	VF
* 31 Series only.			
1"	3/4"	GM	MG
1 1/4"	3/4"	HM	MH
1 1/4"	1"	HN	NH
1 1/2"	1"	WN	NW
1"	3/4"	PN	NP
1"	3/4"	SX	XS

Bearing Carriers (9) (Pump Only) - continued

Metric Split Flange Porting

IN	OUT	CW	CCW
1"	-		
1 1/4"	-	DH	HD
1 1/2"	-	FH	HF
-	3/4"		
1"	3/4"	CW	WC
1 1/4"	3/4"	DW	WD
1 1/2"	3/4"	FW	WF
1 1/4"	1"	DC	CD
1 1/2"	1"	FC	CF
1"	3/4"		
1 1/4"	3/4"	HQ	QH
1 1/4"	1"	HS	SH
1 1/2"	1"	WS	SW
1"	3/4"		
1"	3/4"		

Metric Straight Thread Porting

IN	OUT	CW	CCW
1"	-		
1 1/4"	-	DL	LD
1 1/2"	-	FL	LF
1"	3/4"		
1 1/4"	3/4"	DZ	ZD
1 1/2"	3/4"	FZ	ZF
1 1/4"	1"	DN	ND
1 1/2"	1"	FN	NF
1"	3/4"		
1 1/4"	3/4"	HT	TH
1 1/4"	1"	HV	VH
1 1/2"	1"	WV	VW
1"	3/4"		
1"	3/4"		

Connecting Shaft (10)

For connecting tandem units.

1 Connecting Shaft - Multiple Units

14 Piggyback Pump Connecting Shaft P30 to P30, P31 to P31

22 Piggyback Pump Connecting Shaft P50 to P30, P51 to P31

23 Piggyback Pump Connecting Shaft P75 to P30, P76 to P31

NOTE

Split flange thread depths may be more shallow than S.A.E. standard. Contact Product Support Department for actual dimensions.

Bearing Carriers (9) Motor Only

No Ports

IN	OUT	DUAL
-	-	

NPT Porting (30 Series only)

1"	1"	
1 1/4"	1 1/4"	VV

ODT Porting

1"	1"	
1 1/4"	1 1/4"	BB
1 1/2"	1 1/2"	FF

Split Flange Porting

1"	1"	
1 1/4"	1 1/4"	MM
1 1/2"	1 1/2"	NN

BSPP Porting

1"	1"	
1 1/4"	1 1/4"	GG

Metric Split Flange Porting

IN	OUT	DUAL
1"	1"	
1 1/4"	1 1/4"	SS

Metric Straight Thread Porting

1"	1"	
1 1/4"	1 1/4"	JJ

50/51 Series Coding

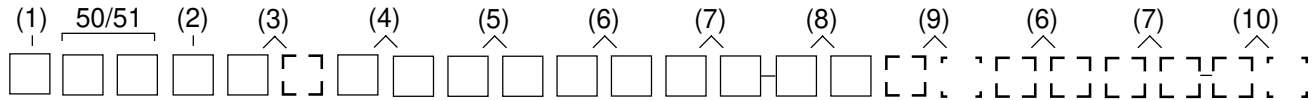

Pump/Motor (1)

P	Pump
M	Motor

Unit (2)

A	Single Unit
B	Tandem Unit
C	Single or Tandem w. two-piece shaft (O.B. bearing required)

Shaft End Cover (3)

1	Pump, cw w/o O.B. bearing
2	Pump, ccw w/o O.B. bearing
3	Pump, bi-rotational w/o O.B. bearing (50 series only)
4	Pump, cw with O.B. bearing
5	Pump, ccw with O.B. bearing
6	Pump, bi-rotational with O.B. bearing (50 series only)
8	Motor, bi-rot. with O.B. bearing + 1/4" NPT drain
9	Motor, bi-rot. w/o O.B. bearing + 1/4" NPT drain
18	Motor, bi-rot. with O.B. bearing + 1/4" BSPP drain
19	Motor, bi-rot. w/o O.B. bearing + 1/4" BSPP drain

Shaft End Cover (4) (type 1 unless noted)

00	4 bolt pad mount
42	SAE 4 bolt "B" ANSI 101-4
78	SAE 4 bolt "C" ANSI 127-4
91	50-50, 51-51 for piggyback
92	75-50, 76-51 for piggyback
96	SAE 2 bolt "B" ANSI 101-2, type 2
97	SAE 2 bolt "B" ANSI 101-2
98	SAE 2 bolt "C" ANSI 127-2
99	SAE 2 bolt "C" ANSI 127-2, type 2

Port End Cover (5) (Rear Ported)

Left	Right	Single	Tandem	Extended Studs
I	I	I	I	I
Unported				
-	-	BE	BI	BY

NPT Porting (50 series only)

3/4"	-	KE	KI	KY
-	3/4"	LE	LI	LY
3/4"	3/4"	ME	MI	MY

O.D.T. Porting

3/4"	-	CE	CI	CY
-	3/4"	DE	DI	DY
3/4"	3/4"	FE	FI	FY

Port End Cover (5) continued

Left	Right	Single	Tandem	Extended Studs
I	I	I	I	I
BSPP Porting				
3/4"	-	WE	WI	WY
-	3/4"	XE	XI	XY
3/4"	3/4"	ZE	ZI	ZY

Metric Straight Thread

3/4"	-	NE	NI	NY
-	3/4"	PE	PI	PY
3/4"	3/4"	QE	QI	QY

Note: 3/4" PEC ports are rated to 2500 PSI max.

	CW	CCW	Double
	I	I	I
Piggyback Port End - Pump Only			
Type 50-50, 51-51 & 50-30, 51-31	KO	LO	MO

Optional:

- Port end cover with integral R/V
- Larger rear ports
1 1/4 x 1 S.F. or ODT
- Larger side ports
1 1/4 S.F. or ODT inlet
1" ODT outlet
- Larger rear ports, but requires special gear housing and cap screws
1 1/2 x 1 1/2 NPT up to 1500 PSI

Contact Product Support Development for additional information.

FOR ALL UNITS

To determine direction of shaft rotation, view the unit with the shaft pointing toward you, and the idler (driven) gear beneath the shaft. With clockwise rotation, flow will be left to right. The inlet pump port will be on the left, outlet on the right. The flow is in the opposite direction with counter-clockwise rotation. Inverting the pump will reverse the inlet and outlet ports but not the direction of rotation.

Gear Housing (6)

Series	50	50	50	50	50	50	50	50	51	51	51	51	51	51	51								
Housing Code	07	10	12	15	17	20	22	25	10	12	15	17	20	22	25								
Displacement (C.I.R.)	1.91	2.55	3.19	3.83	4.46	5.10	5.74	6.38	2.55	3.19	3.83	4.46	5.10	5.74	6.38								
Maximum (PSI)	2500	2500	2500	2500	2000	2000	2000	2000	3000	3000	3000	3000	2500	2500	2500								
IN	OUT	CW	CCW																				
-	-	AB	AB	X	X	X	X	X	X	X	X	X	X	X	X								
												No Porting											
												NPT Porting											
3/4"	-	IC	ID	X	ID	ID	ID																
-	3/4"	ID	IC	X	ID	ID	ID																
3/4"	3/4"	IF	IF	X	X	X	X	X															
1"	3/4"	IJ	IG	X*	X	X	IJ	IJ															
1 1/4"	3/4"	IK	IH					X															
1"	-	YC	YD				X	YD	YD	YD	YD												
-	1"	YD	YC				X	YD	YD	YD	YD												
1"	1"	YF	YF					X	X	X	X	X	X										
1 1/4"	1"	YJ	YG					X*	X	X	X	YJ											
1 1/4"	-	IA	IB					X*	X*	X	IB	IB											
-	1 1/4"	IB	IA								X	IB	IB										
1 1/4"	1 1/4"	YL	YL					X	X	X	X												
1 1/2"	1"	YK	YH									X											
1 1/2"	1 1/4"	YP	YM					X*	X	X													
1 1/2"	1 1/2"	YR	YR									X											
												OD Tube Porting											
3/4"	-	EC	ED	2000	2000	X	ED	X	X*	X*	OD Tube Porting		X										
-	3/4"	ED	EC	2000	2000	X	ED	X							X								
3/4"	3/4"	EF	EF	2000	2000	X	X	X							2500	X							
1"	3/4"	EJ	EG	2000*	2000*	X	EJ*	EJ							X								
1 1/4"	3/4"	EK	EH					X*	X*							2500*	X*						
1"	-	AC	AD	X*	X*	2000	X	AD	AD	AD	X*	X*	X*	X*	X								
-	1"	AD	AC					2000	X	AD	AD	AD						X					
1"	1"	AF	AF					2000	X	X	X						X	X	X				
1 1/4"	1"	AJ	AG					2000*	X*	X*	AJ	AJ						X*					
1 1/2"	1"	AK	AH					X*	X*	X*							X*				X		
1 1/4"	-	AA	AO					X*	X*	X*	AO	AO					X*	X*	X	X			
-	1 1/4"	AO	AA								AO	AO						X	X				
1 1/4"	1 1/4"	AL	AL								X	X	X						X	X			
1 1/2"	1 1/4"	AP	AM								X*	X*	X						X*	X*			
1 1/2"	-	AE	AU								X*	X*							X*	X*			X
-	1 1/2"	AU	AE																X				
1 1/2"	1 1/2"	AR	AR																X				

NOTES

NPT ports are not recommended for use at pressures in excess of 1500 PSI.
 Shaded cells are acceptable for motor codes.
 * This porting is acceptable for low pressure inlet port only.
 "X" Means both codes are available.
 "2000" or "2500" indicates maximum pressure rating on port.

Gear Housing (6) *continued*

Series	50	50	50	50	50	50	50	51	51	51	51	51	51	51					
Housing Code	10	12	15	17	20	22	25	10	12	15	17	20	22	25					
Displacement (C.I.R.)	2.55	3.19	3.83	4.46	5.10	5.74	6.38	2.55	3.19	3.62	4.46	5.10	5.74	6.38					
Maximum (PSI)	2500	2500	2500	2000	2000	2000	2000	3000	3000	3000	3000	2500	2500	2500					
IN	OUT	CW	CCW																
I	I	I	I	I	I	I	I	I	I	I	I	I	I	I					
3/4"	-	UC	UD	X	X	UD	UD												
-	3/4"	UD	UC	X	X	UD	UD												
3/4"	3/4"	UF	UF					X		X									
1**	3/4"	UJ	UG	X*	X*	UJ	UJ	UJ											
1 1/4**	3/4"	UK	UH																
1**	-	OC	OD	2000	X*	X	X	X	OD	X									
-	1"	OD	OC	2000	2000	X	X	X	OD	X									
1"	1"	OF	OF		2000	X	X	X	X	X									
1 1/4**	1"	OJ	OG		2000*	X*	X*	X	OJ	OJ									
1 1/2**	1"	OK	OH			X*	X*	X*	X	X									
1 1/4**	-	OA	OB			X*	X*	X*	X	OB	OB								
-	1 1/4"	OA	OB						X	OB	OB								
1 1/4"	1 1/4"	OL	OL			2000	X	X	X	X			X	X	X				
1 1/2**	1 1/4"	OP	OM			2000*	X*	X*	X	X			X*	X	X				
1 1/2**	-	OE	OU				X*	X*	X	X			X*	X*	X*				
-	1 1/2"	OU	OE						X	X									
1 1/2"	1 1/2"	OR	OR						X	X	X			X	X				
2**	-	XB	ZB											X*					
2**	1"	UQ	UB					X*	X*	X*									
2**	1 1/4"	OQ	ON					X*	X*	ON*			X*	X*	X*				
2**	1 1/2"	OV	OS					X*	X*	X*				X*	X*				
2"	2"	OX	OX							X									
BSPP Porting																			
3/4**	-	YN	YQ	X*	X	YQ	YQ						X*	2500	2500	YQ	YQ		
-	3/4"	YQ	YN		X	YQ	YQ							2500	2500	YQ	YQ		
3/4"	3/4"	YS	YS	2000	X	X				X				2500	2500		X		
1**	3/4"	YV	YT	2000*	X*	YV*	YV*	YV						2500*	2500*	YV*	YV*		
1 1/4**	3/4"	YW	YU				YW*												
1**	-	SL	RQ		SL*	RQ*	RQ*	RQ	RQ	RQ			RQ*	SL*	RQ*	RQ*	RQ*	RQ	RQ
-	1"	RQ	SL					RQ	RQ	RQ						2500	RQ	RQ	
1"	1"	MP	MP			2000	X	X		X						2500			X
1 1/4**	1"	IX	VY			2000*	X*	VY*	IX	IX						2500*	IX	IX	
1 1/2"	1"	VI	HW							X									
1 1/4**	-	NJ	UI					NJ*		UI	UI							UI	UI
-	1 1/4"	UI	NJ							UI	UI							UI	UI
1 1/4"	1 1/4"	PF	PF						X	X								X	X
1 1/2**	1 1/4"	IS	IQ							X									X*
Metric Straight Thread																			
3/4**	-	EN	TQ	X*	TQ	TQ	TQ						X*	TQ*	TQ*	TQ			
-	3/4"	TQ	EN		TQ	TQ	TQ							2500	2500	TQ			
3/4"	3/4"	ES	ES	2000	X									2500					
1**	3/4"	EV	ET	2000*	X*	EV*	EV	EV						2500*	2500*	EV*	EV*		
1**	-	NL	ER			ER*	ER	ER	ER							ER*	ER*	ER*	ER
-	1"	ER	NL				ER	ER	ER										
1"	1"	CM	CM			2000	X	X								2500			
1 1/4**	-	UA						UA*	UA	UA							UA*	UA	UA
1 1/4**	1"	EX	VE			2000*	X*	EX*	EX	EX						2500*	X*	EX	EX
1 1/4"	1 1/4"	PA	PA					X	X	X								X	X
1 1/2**	1 1/4"	SA	QA					X*	X*	X								X*	X*

NOTES: Shaded cells are acceptable for motor codes. * This porting is acceptable for low pressure inlet port only. "X" Means both codes are available. "2000" or "2500" indicates maximum pressure rating on port.

Gear Housing (6) *continued*

Series	50	50	50	50	50	50	50	51	51	51	51	51	51	51		
Housing Code	10	12	15	17	20	22	25	10	12	15	17	20	22	25		
Displacement (C.I.R.)	2.55	3.19	3.83	4.46	5.10	5.74	6.38	2.55	3.19	3.62	4.46	5.10	5.74	6.38		
Maximum (PSI)	2500	2500	2500	2000	2000	2000	2000	3000	3000	3000	3000	2500	2500	2500		
IN	OUT	Metric Split Flange Porting														
CW	CCW															
3/4**	-	VN	VQ	VQ	VQ	VQ	VQ									X*
-	3/4"	VQ	VN	VQ	VQ	VQ	VQ									
1**	3/4"	RV	VT	X*	RV*	RV	RV	RV								2500* X*
1 1/4**	3/4"	RW	RU													X* X*
1**	-	UL	UR		UR*	UR	UR	UR	UR							X* X* X X
-	1"	UR	UL			UR	UR	UR	UR							X X
1"	1"	UM	UM		2000	X	X	X	X							2500 X X X
1 1/4**	1"	UX	VU		2000*	UX*	UX*	UX	UX	UX						2500* X* X*
1 1/2**	1"	VO	HO			X*	X*	X*								2500* X* X* X
1 1/4**	-	NO	UO				UO*	UO	UO	UO						X* X*
-	1 1/4"	UO	NO					UO	UO	UO						
1 1/4"	1 1/4"	PO	PO		2000	X	X	X	X							X X X
1 1/2**	1 1/4"	SO	QO		2000*	X*	X*	X	X							X* X X
1 1/2**	-	UY	TO			X*	X*			X						X* X*
-	1 1/2"	TO	UY							X						
1 1/2"	1 1/2"	SV	SV					X	X	X						X X
2**	1 1/4"	JM	JR					X*	X*	X*						X* X* X*
2**	1 1/2"	JQ	JN					X*	X*	X*						X* X*

NOTES

Shaded cells are acceptable for motor codes.
 * This porting is acceptable for low pressure inlet port only.
 "X" Means both codes are available.
 "2000" or "2500" indicates maximum pressure rating on port.

Gear Width (7)

50 Series

	Gear Width	in. ³ /rev.	cm ³ /rev.	Max Pressure
05	1/2"	1.28	20.9	2500 psi (172 bar)
07	3/4"	1.91	31.3	2500 psi (172 bar)
10	1"	2.55	41.8	2500 psi (172 bar)
12	1 1/4"	3.19	52.2	2500 psi (172 bar)
15	1 1/2"	3.83	62.7	2500 psi (172 bar)
17	1 3/4"	4.46	73.1	2000 psi (138 bar)
20	2"	5.10	83.6	2000 psi (138 bar)
22	2 1/4"	5.74	94.0	2000 psi (138 bar)
25	2 1/2"	6.38	104.5	2000 psi (138 bar)

51 Series

	Gear Width	in. ³ /rev.	cm ³ /rev.	Max Pressure
05	1/2"	1.28	20.9	3000 psi (207 bar)
07	3/4"	1.91	31.3	3000 psi (207 bar)
10	1"	2.55	41.8	3000 psi (207 bar)
12	1 1/4"	3.19	52.2	3000 psi (207 bar)
15	1 1/2"	3.83	62.7	3000 psi (207 bar)
17	1 3/4"	4.46	73.1	3000 psi (207 bar)
20	2"	5.10	83.6	2500 psi (172 bar)
22	2 1/4"	5.74	94.0	2500 psi (172 bar)
25	2 1/2"	6.38	104.5	2500 psi (172 bar)

Shaft Type (8) *(type 1 unless noted)*

For single, tandem, or two piece shaft unless noted.

- 07 SAE "C" 14 tooth spline 1.25" dia.,
ANSI 32-4
- 11 SAE "C" keyed 1.25" dia., 5/16"x15/32"x1 1/2" key,
ANSI 32-1
- 22 50-50, 51-51 piggyback shaft
- 23 75-50, 76-51 piggyback shaft
- 25 SAE "B" 13 tooth spline .88" dia., ANSI 22-4
- 43 SAE "B-B" keyed 1.00" dia. 1/4"x3/8"x1 1/4" key,
ANSI 25-1
- 53 SAE "C" 14 tooth spline 1.25" dia.,
ANSI-32-4, **type 2** (single & tandem)
- 65 SAE "B" 13 tooth spline .88" dia.,
ANSI 22-4, **type 2** (single & tandem)
- 67 SAE "B-B" keyed 1.00 dia., 1/4"x3/8"x1 1/4" key,
ANSI 25-1, **type 2** (single & tandem)
- 73 SAE "C" keyed 1.25" dia., 5/16" x 15/32" x 2 1/4" key,
extended length (two-piece only)
- 98 SAE "B-B" 15 tooth spline, 1.00" dia.,
ANSI 25-4 (single & tandem)

Bearing Carriers (9) Pump Only

Common Inlet Passage

IN	OUT	CW	CCW
-	-	C	D
*	-	A	U

* 51 Series only. Used when only one adjacent gear housing has an inlet port.

NPT Porting (50 Series only)

1"	-	TB	BT
1 1/4"	-	VB	BV
1 1/2"	-	WB	BW
1"	3/4"	TX	XT
1 1/4"	3/4"	VX	XV
1 1/2"	3/4"	WX	XW
1 1/4"	1"	VZ	ZV
1 1/2"	1"	WZ	ZW
1"	3/4"	TJ	JT
1 1/4"	3/4"	VJ	JV
1 1/4"	1"	VK	KV
1 1/2"	1"	WK	KW
1"	3/4"	ZX	XZ

ODT Porting

1"	-	CB	BC
1 1/4"	-	DB	BD
1 1/2"	-	FB	BF
-	3/4"	PJ	*JP
1"	3/4"	CJ	JC
1 1/4"	3/4"	DJ	JD
1 1/2"	3/4"	FJ	JF
1 1/4"	1"	DK	KD
1 1/2"	1"	FK	KF

* 51 Series only.

1"	3/4"	CR	RC
1 1/4"	3/4"	DR	RD
* 1 1/2"	3/4"	FR	RF
1 1/4"	1"	DS	SD
1 1/2"	1"	FS	SF
-	1"	HZ	*ZH

* 51 Series only.

1"	3/4"	KJ	JK
----	------	----	----

NOTE

Split flange thread depths may be more shallow than S.A.E. standard. Contact Product Support Department for actual dimensions.

Bearing Carriers (9) Pump Only - continued

Metric Split Flange Porting

IN	OUT	CW	CCW
1"	-	CH	HC
1 1/4"	-	DH	HD
1 1/2"	-	FH	HF
-	3/4"	PW	WP
1"	3/4"	CW	WC
1 1/4"	3/4"	DW	WD
1 1/2"	3/4"	FW	WF
1 1/4"	1"	DC	CD
1 1/2"	1"	FC	CF
1"	3/4"	GQ	QG
1 1/4"	3/4"	HQ	QH
1 1/2"	3/4"	WQ	QW
1 1/4"	1"	HS	SH
1 1/2"	1"	WS	SW
1"	3/4"	ST	TS

Metric Straight Thread Porting

IN	OUT	CW	CCW
1"	-	CL	LC
1 1/4"	-	DL	LD
1 1/2"	-	FL	LF
1"	3/4"	CZ	ZC
1 1/4"	3/4"	DZ	ZD
1 1/2"	3/4"	FZ	ZF
1 1/4"	1"	DN	ND
1 1/2"	1"	FN	NF
1"	3/4"	GT	TG
1 1/4"	3/4"	HT	TH
1 1/2"	3/4"	WT	TW
1 1/4"	1"	HV	VH
1 1/2"	1"	WV	VW
1"	3/4"	KL	LK

Bearing Carriers (9) (Motor Only)

No Ports

IN	OUT	DUAL
-	-	B

NPT Porting (30 Series only)

1"	1"	TT
1 1/4"	1 1/4"	VV
1 1/2"	1 1/2"	WW

ODT Porting

1"	1"	CC
1 1/4"	1 1/4"	BB
1 1/2"	1 1/2"	FF

Split Flange Porting

1"	1"	LL
1 1/4"	1 1/4"	MM
1 1/2"	1 1/2"	NN

BSPB Porting

IN	OUT	DUAL
1"	1"	EE
1 1/4"	1 1/4"	GG

Metric Split Flange Porting

1"	1"	RR
1 1/4"	1 1/4"	SS

Metric Straight Thread Porting

1"	1"	KK
1 1/4"	1 1/4"	JJ

Connecting Shaft (10)

For connecting tandem units.

1 Connecting Shaft - Multiple Units

22 Piggyback Pump Connecting Shaft for P50 to P50, P51 to P51

23 Piggyback Pump Connecting Shaft for P75 to P50, P76 to P51

75/76 Series Coding

APPENDIX C

Tandem: Repeat if Necessary

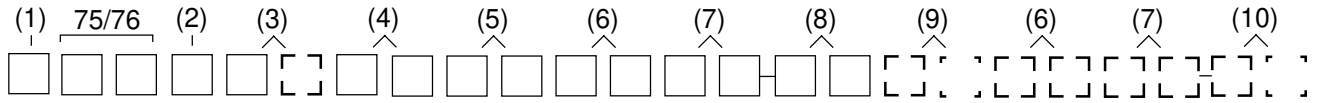

Pump/Motor (1)

P Pump

M Motor

Unit (2)

A Single Unit

B Tandem Unit

C Single or Tandem w/ two-piece shaft (O.B. bearing required)

Shaft End Cover (3)

1 Pump, cw w/o O.B. bearing

2 Pump, ccw w/o O.B. bearing

3 Pump, bi-rotational w/o O.B. bearing (75 series only)

4 Pump, cw with O.B. bearing

5 Pump, ccw with O.B. bearing

6 Pump, bi-rotational w/ O.B. bearing (75 series only)

8 Motor, bi-rot. with O.B. bearing + 1/4" NPT drain

9 Motor, bi-rot. w/o O.B. bearing + 1/4" NPT drain

18 Motor, bi-rot. with O.B. bearing + 1/4" BSPP drain

19 Motor, bi-rot. w/o O.B. bearing + 1/4" BSPP drain

Shaft End Cover (4) (type 1 only)

42 SAE 4 bolt "B" ANSI 101-4

78 SAE 4 bolt "C" ANSI 127-4

80 SAE 4 bolt "D" ANSI 152-4

98 SAE 2 bolt "C" ANSI 127-2

Port End Cover (5) (Rear Ported)

Left	Right	Single	Tandem	Extended Studs

Unported

-	-	BE	BI	BY
---	---	----	----	----

O.D.T. Porting

1"	1"	JE	JI	JY
----	----	----	----	----

Metric Straight Thread

1"	1"	TE	TI	TY
----	----	----	----	----

CW	CCW	Double

Piggyback Port End - Pump Only

Type 75-50, 76-51 & 75-30, 76-31	KO	LO	MO
----------------------------------	----	----	----

For All Units

To determine direction of shaft rotation, view the unit with the shaft pointing toward you, and the idler (driven) gear beneath the shaft. With clockwise rotation, flow will be left to right. The inlet pump port will be on the left, outlet on the right. The flow is in the opposite direction with counter-clockwise rotation. Inverting the pump will reverse the inlet and outlet ports but not the direction of rotation.

Gear Housing (6)

Series	75	75	75	75	75	75/76	75	75	75/76	75/76	76	76	76	76	76	76	
Housing Code	07	10	12	15	17	20	22	25	27	30	10	12	15	17	22	25	
Displacement (C.I.R.)	3.07	4.1	5.12	6.15	7.17	8.2	9.22	10.25	11.275	12.3	4.1	5.12	6.15	7.17	9.22	10.25	
Maximum (PSI)	2500	2500	2500	2500	2500	2500	2250	2250	2000	2000	3000	3000	3000	3000	2500	2500	
IN OUT CW CCW											No Porting						
-	-	AB	AB	X	X	X	X	X	X	X	X	X	X	X	X	X	X
											NPT Porting						
3/4"	-	IC	ID	ID	ID	ID	ID	ID	ID	ID							
-	3/4"	ID	IC	ID	ID	ID	ID	ID	ID	ID							
1"	3/4"	IJ	IG		X	IJ	IJ										
1"	-	YC	YD			YD	YD		X/-								
-	1"	YD	YC			YD	YD		X/-								
1"	1"	YF	YF		X	X											
1 1/4"	1"	YJ	YG			X	X										
1 1/4"	1 1/4"	YL	YL			X	X	X									
											OD Tube Porting						
3/4"	-	EC	ED	ED	ED	ED	ED	ED	ED	ED							
1"	3/4"	EJ	EG	X*		EJ	EJ				2500*						
1 1/4"	3/4"	EK	EH		X*							X*					
1"	-	AC	AD			AD	AD					2500	X				
-	1"	AD	AC			AD	AD					2500	X				
1"	1"	AF	AF		2000	X	X	X	X/-			2500	X				
1 1/4"	1"	AJ	AG		2000*	X*						2500*	X*				
1 1/2"	1"	AK	AH				X*							X*			
1 1/4"	1 1/4"	AL	AL			2000	2000	2000/-	X	X				X/-			
1 1/2"	1 1/4"	AP	AM			2000*	2000*										
1 1/2"	1 1/2"	AR	AR						X	X							
											Split Flange Porting						
3/4"	-	UC	UD	UD	UD	UD	UD	UD	UD	UD							
-	3/4"	UD	UC	UD	UD	UD	UD	UD	UD	UD							
1"	3/4"	UJ	UG	X	X	UJ	UJ	UJ	UJ	UJ		X					
1"	-	OC	OD		OD	X	OD	OD	OD	OD							
-	1"	OD	OC		OD	X	OD	OD	OD	OD							
1"	1"	OF	OF		X	X	X	X	X/X		X	X/-	X/-	X	X	X	X
1 1/4"	1"	OJ	OG		2000*	X	X	OJ	OJ/-	OJ	OJ		-/X	X*	X*		
1 1/2"	1"	OK	OH			X*	X*	X*	X/-	X				X*	X*	X*	
1 1/4"	-	OA	OB			OB	OB	OB	OB/-	OB	OB						
-	1 1/4"	OB	OA			OB	OB	OB	OB/-	OB	OB						
1 1/4"	1 1/4"	OL	OL		2000	X	X	X	X/X	X	X	X/X	X/X	2500	X	X	X
1 1/2"	1 1/4"	OP	OM			X*	X*	X*	X/X	X	X	OP/-	OP/-	2500*	X*	X*	X
1 1/2"	-	OE	OU					X/X	X	OU	OU/-	OU/-	OU/-				X
-	1 1/2"	OU	OE					X/X	X	OU	OU/-	OU/-	OU/-				X
1 1/2"	1 1/2"	OR	OR			2000	2000	X/X	X	X	X	X/X	X/X				X
2"	1"	UQ	-					X*/-									
2"	1 1/4"	OQ	ON				X*	X*/X*	X*	X*	X/X	X/X			X*	X*	X*
2"	1 1/2"	OV	OS			2000*	X*/X*	X*	X*	X/X	X/X				X*	X*	X*
2"	2"	OX	OX							X	X/X	X/X					
2 1/2"	1 1/4"	US	UN							X*							
2 1/2"	1 1/2"	OW	OT							X*	X*/X*	X*/X*					X*
2 1/2"	2"	OZ	OY														X*/-

NOTES

NPT ports are not recommended for use at pressures in excess of 1500 PSI.

Shaded cells are acceptable for motor codes.

* This porting is acceptable for low pressure inlet port only.

"X" Means both codes are available.

"2000" or "2500" indicates maximum pressure rating on port.

Gear Housing (6) *continued*

Series	75	75	75	75	75	75/76	75	75	75/76	75/76	76	76	76	76	76	76
Housing Code	07	10	12	15	17	20	22	25	27	30	10	12	15	17	22	25
Displacement (C.I.R.)	3.07	4.1	5.12	6.15	7.17	8.2	9.22	10.25	11.275	12.3	4.1	5.12	6.15	7.17	9.22	10.25
Maximum (PSI)	2500	2500	2500	2500	2500	2500	2250	2250	2000	2000	3000	3000	3000	3000	2500	2500
											BSPP Porting					
IN	OUT	CW	CCW													
3/4"	-	YN	YQ	YQ	YQ	YQ	YQ	YQ	YQ/-		YQ	YQ	YQ			
-	3/4"	YQ	YN	YQ	YQ	YQ	YQ	YQ	YQ/-		YQ	YQ	YQ			
3/4"	3/4"	YS	YS								X					
1"	3/4"	YV	YT	X*	YV*	YV	YV	YV	YV/YV		X*	YV*	YV		YV	
1"	-	SL	RQ			X	RQ	RQ	RQ/RQ	RQ	SL*	RQ*	RQ			RQ
-	1"	RQ	SL			X	RQ	RQ	RQ/RQ	RQ			RQ			RQ
1"	1"	MP	MP		2000	X	X					2500	X	X		
1 1/4"	1"	IX	VY		2000*	X*	IX*		IX/-	IX		2500*	IX*		X*	
1 1/4"	-	NJ	UI				UI*									UI
-	1 1/4"	UI	NJ													UI
1 1/4"	1 1/4"	PF	PF			2000	2000	X/-		X					X	X
1 1/2"	1"	VI	HW			X*	VI*	-/VI*					VI*			
1 1/2"	1 1/4"	IS	IQ			2000*	2000*	-/X*							X*	
											Metric Straight Thread					
3/4"	-	EN	TQ	TQ	TQ	TQ	TQ	TQ			TQ	TQ	TQ			
-	3/4"	TQ	EN	TQ	TQ	TQ	TQ	TQ			TQ	TQ	TQ			
1"	3/4"	EV	ET	X*			EV	EV				EV*	EV			
1"	-	NL	ER									ER*	ER			
-	1"	ER	NL				ER	ER				2500	ER			
1"	1"	CM	CM		2000	X	X					2500	X			
											Metric Split Flange Porting					
3/4"	-	VN	VQ	VQ	VQ	VQ	VQ	VQ								
-	3/4"	VQ	VN	VQ	VQ	VQ	VQ	VQ								
1"	3/4"	RV	VT	X	X	RV	RV	RV	RV/-		X					
1"	-	UL	UR			UR	UR	UR	UR	UR/-						
-	1"	UR	UL			UR	UR	UR	UR	UR/-						
1"	1"	UM	UM			X	X	X	X	X/X		X	X	X	X	
1 1/4"	1"	UX	VU			X*	X	UX	UX	UX/-	UX	UX				
1 1/2"	1"	VO	HO				X*	X*					X*	X*		
1 1/4"	-	NO	UO				UO	UO	UO	UO/-	UO	UO				
-	1 1/4"	UO	NO				UO	UO	UO	UO/-	UO	UO				
1 1/4"	1 1/4"	PO	PO			X	X	X	X/X	X	X	X	X	X	X	X
1 1/2"	1 1/4"	SO	QO				X*	X*	X/X	X	SO	SO	SO			
1 1/2"	-	UY	TO						X/X	X	X	TO	TO		X*	X
-	1 1/2"	TO	UY						X/X	X	X	TO	TO			X
1 1/2"	1 1/2"	SV	SV				2000	X/X	X	X	X/X	X/X				X
2"	1 1/4"	JM	JR				X*	X*/X*	X*	X*	-/X*	-/X*		X*	X*	X*
2"	1 1/2"	JQ	JN				2000*	X*/X*	X*	X*	X/X	X/X			X*	X*
2"	2"	JS	JS								-/X	X/X				
2 1/2"	1 1/2"	LJ	JX								X*/X*	X*/X*				X*

NOTES

Shaded cells are acceptable for motor codes.

* This porting is acceptable for low pressure inlet port only.

"X" Means both codes are available.

"2000" or "2500" indicates maximum pressure rating on port.

Gear Width (7)

75 Series

	Gear Width	in. ³ /rev.	cm ³ /rev.	Max Pressure
07	3/4"	3.08	50.4	2500 psi (172 bar)
10	1"	4.10	67.2	2500 psi (172 bar)
12	1 1/4"	5.13	84.0	2500 psi (172 bar)
15	1 1/2"	6.15	100.8	2500 psi (172 bar)
17	1 3/4"	7.18	117.6	2500 psi (172 bar)
20	2"	8.20	134.4	2500 psi (172 bar)
22	2 1/4"	9.23	151.2	2250 psi (155 bar)
25	2 1/2"	10.25	168.0	2250 psi (155 bar)
27	2 3/4"	11.28	184.8	2000 psi (138 bar)
30	3"	12.30	201.6	2000 psi (138 bar)

76 Series

	Gear Width	in. ³ /rev.	cm ³ /rev.	Max Pressure
07	3/4"	3.08	50.4	3000 psi (207 bar)
10	1"	4.10	67.2	3000 psi (207 bar)
12	1 1/4"	5.13	84.0	3000 psi (207 bar)
15	1 1/2"	6.15	100.8	3000 psi (207 bar)
17	1 3/4"	7.18	117.6	3000 psi (207 bar)
20	2"	8.20	134.4	2500 psi (172 bar)
22	2 1/4"	9.23	151.2	2500 psi (172 bar)
25	2 1/2"	10.25	168.0	2500 psi (172 bar)
27	2 3/4"	11.28	184.8	2000 psi (138 bar)
30	3"	12.30	201.6	2000 psi (138 bar)



Shaft Type (8)

For single, tandem, or two piece shaft unless noted.

07	SAE "C" 14 tooth spline 1.25" dia., ANSI 32-4
11	SAE "C" keyed 1.25" dia., 5/16"X15/32"X1 1/2" key, ANSI 32-1

Bearing Carriers (9) (Pump Only)

Common Inlet Passage

			
-	-	C	D
* -	-	A	U

* 76 Series only. Used when only one adjacent gear housing has an inlet port.

Bearing Carriers (9) (Motor Only)

No Ports

IN	OUT	DUAL
I	I	I
		
-	-	B

ODT Porting

		
1"	1"	CC
1 1/4"	1 1/4"	BB

Split Flange Porting

		
* 1"	1"	LL
1 1/4"	1 1/4"	MM
1 1/2"	1 1/2"	NN

* 76 Series only.

BSPB Porting

		
1"	1"	EE
1 1/4"	1 1/4"	GG
1 1/2"	1 1/2"	HH

Metric Split Flange Porting

IN	OUT	DUAL
I	I	I
		
1"	1"	RR
1 1/4"	1 1/4"	SS
1 1/2"	1 1/2"	XX

Metric Straight Thread Porting

		
1"	1"	KK
1 1/4"	1 1/4"	JJ
1 1/2"	1 1/2"	ZZ

Connecting Shaft (10)

For connecting tandem units.

1 Connecting Shaft - Multiple Units

23 Piggyback Pump Connecting Shaft for P75 to P75

NOTE

Split flange thread depths may be more shallow than S.A.E. standard. Contact Product Support Department for actual dimensions.



Commercial Hydraulics

AUSTRALIA

Commercial Hydraulics
265 Ingles Street, P.O. Box 191
Port Melbourne, Victoria 3207
Phone: ++ 61 39 646 2017
Fax: ++ 61 39 646 2257

BRAZIL

Commercial Intertech do Brazil
Rua AMF do Brazil, 251
18120 Mairinque, Sao Paulo
Phone: ++ 55 11 7998 2333
Fax: ++ 55 11 7998 2099

CANADA

Commercial Hydraulics
294 Queen St. East, Suite C
P.O. Box 450
Acton, Ontario L7J 2M6
Phone: ++ 519 853 0770
Phone: ++ 519 853 3837

FRANCE

Commercial Hydraulics
Astron S.a.r.l. BP 73
20, rue Pierre Mendès-France, Torcy
77202 Marne La Vallée, Cedex 01
Phone: ++ 33 1 64 62 11 00
Fax: ++ 33 1 64 62 10 93

GERMANY

Commercial Hydraulics/Rochlitz
Dresdener Str. 115
09326 Geringswalde
Telefon: ++ 49 - 37382 82 0
Fax: ++ 49 - 37382 82 210

Commercial Hydraulics/ Sachsenhydraulik

Postfach 1153 09070 Chemnitz
Neefstraße 96 09116 Chemnitz
Phone: ++ 49 - 371 39 37 0
Fax: ++ 49 - 371 30 13 88

GREAT BRITAIN

Commercial Hydraulics/Kontak
Belton Park, Londonthorpe Rd.
Grantham NG31 9SJ, Lincolnshire
Phone: ++ 44 1476 564105
Fax: ++ 44 1476 592739

Commercial Hydraulics/Ultra

Anson Business Park,
Cheltenham Road East, Nr Staverton
Airport, Gloucester. GL2 9QN
Phone: ++ 44 1452 857711
Fax: ++ 44 1452 858222

Commercial Hydraulics/Keelavite

Tachbrook Park Drive, Tachbrook Park
Warwick CV34 6TU
Phone: ++ 44 1926 889 000
Fax: ++ 44 1926 889 239

ITALY

Commercial Hydraulics
Via dell' Agricoltura I/A
I- 37012 Bussolengo, Verona
Phone: ++ 39 45 676 7250
Fax: ++ 39 45 676 7229

SWEDEN

Commercial Hydraulics
Veddestavagen 24
S-175 62 Järfälla
Phone: ++ 46 8 445 7470
Fax: ++ 46 8 445 7475

USA

**Commercial Hydraulics/
Cylinder City**
1532 93rd Lane, N.E.
P.O. Box 49920
Minneapolis, Minnesota 55449
Phone: ++ 612 780 2550
Fax: ++ 612 780 2565

Commercial Hydraulics/Oildyne
5520 North Highway 169
Minneapolis, Minnesota 55428 4998
Phone: ++ 612 533 1600
Fax: ++ 612 533 0082

**Commercial Hydraulics/
Cylinder Division**
20138 I-30; P.O. Box 647
Benton, Arkansas 72018 0647
Phone: ++ 501 794 0334
Fax: ++ 501 794 0732

Commercial Hydraulics
7600 S. County Line Road, Suite #5
Burr Ridge, Illinois 60521
Phone: ++ 630 734 0014
Fax: ++ 630 734 0015

Commercial Hydraulics
2655 Villa Creek Drive, Suite 299
Dallas, Texas 75234 7311
Phone: ++ 214 241 1975
Fax: ++ 214 241 2128

**Commercial Hydraulics/
Controls Division**
373 Meuse Argonne
Hicksville, Ohio 43526
Phone: ++ 419 542 6611
Fax: ++ 419 542 8871

USA

**Commercial Hydraulics/
Pump Division**
101 Canterbury Road, P.O. Box 219
Kings Mountain, North Carolina
28086
Phone: ++ 704 739 8232
Fax: ++ 704 739 2269

**Commercial Hydraulics/
Pump Division**
1775 Logan Ave.
Youngstown, Ohio 44501
Phone: ++ 330 740 8376
Fax: ++ 330 740 8704

**Commercial Hydraulics/
Cylinder Division**
2701 Intertech Drive
Youngstown, Ohio 44509
Phone: ++ 330 740 8670
Fax: ++ 330 740 8636

Commercial Hydraulics/CEC
7850 Park Drive
Chanhassen, Minnesota 55317
Phone: ++ 612 474 0909
Fax: ++ 612 474 7908

CORPORATE HEADQUARTERS

Commercial Intertech Corp.
1775 Logan Ave.
Youngstown, Ohio 44501
PO Box 239
Phone: ++ 330 746 8011
Fax: ++ 330 746 1148



Moduflow™ *Plus* Series

ILP and RFP Low Pressure Filters



Low Pressure Filters

Moduflow™ Plus Series

Applications for Moduflow Filters

- Power Unit Fabrication
- Off-line Filter Loops
- Mobile Equipment

The Moduflow filter is widely considered the most versatile filter available on the market. The unique diverter valve assembly, and inside to outside flow through the element, allows the Moduflow to be configured for in-line, in-tank or suction filtration.

The flow diverter minimizes turbulence and pressure loss through the filter, improving system performance.

The newly designed closed bottom elements for the RFP and ILP models insures all contamination remains trapped within the element as the filter is serviced.

A wide variety of visual and electrical indicators allows you to know exactly when the element needs to be serviced. There is even a "no element" indicator that can sense when there is not an element installed in the filter.

From top to bottom, the Moduflow filter series provides the high level of filtration and long term dependability so vital to today's hydraulic systems.



Parker's new patented Moduflow element was designed with built-in diverter cone and bypass valve, to meet your application needs.

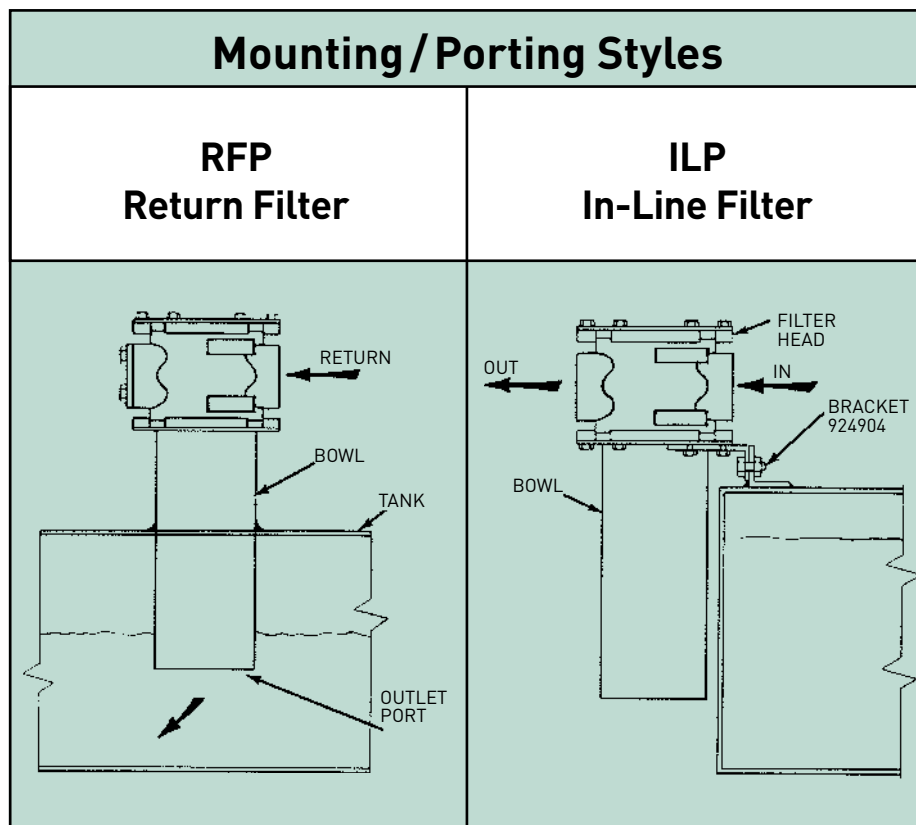

Features

Flanges

- NPT or SAE 3/4" to 2"
- Lightweight aluminum

Cover

- Slotted for quick release
- Lightweight aluminum

Indicators

- Visual or electrical
- Mounted on either side
- Standard "no element" indication

Bowl

- Single or double length
- Durable steel construction

Bypass

(not visible)

- Integral 35 psi bypass replaced with every element change

Element

(not visible)

- Available in cellulose, wire mesh or high performance Microglass III media
- Single or double length



Feature	Advantage	Benefit
<ul style="list-style-type: none"> • Top access element service 	<ul style="list-style-type: none"> • Oil remains in housing • Quicker elements change 	<ul style="list-style-type: none"> • No Spills • Reduced maintenance costs
<ul style="list-style-type: none"> • Slotted cover 	<ul style="list-style-type: none"> • Quick release cover • Cap screws remain in housing 	<ul style="list-style-type: none"> • Reduced maintenance costs • No loose parts to lose
<ul style="list-style-type: none"> • Closed bottom elements 	<ul style="list-style-type: none"> • Removes all contaminant during element service 	<ul style="list-style-type: none"> • No downtime contamination from servicing
<ul style="list-style-type: none"> • Visual or electrical indicators 	<ul style="list-style-type: none"> • Know exactly when to service elements 	<ul style="list-style-type: none"> • Helps prevent bypass condition • No premature disposal
<ul style="list-style-type: none"> • Flange face ports 	<ul style="list-style-type: none"> • Flexible mounting (3/4" to 2") 	<ul style="list-style-type: none"> • Easy plumbing to your system

Low Pressure Filters

Moduflow™ Plus Series

RFP-1 & ILP-1 Element Performance

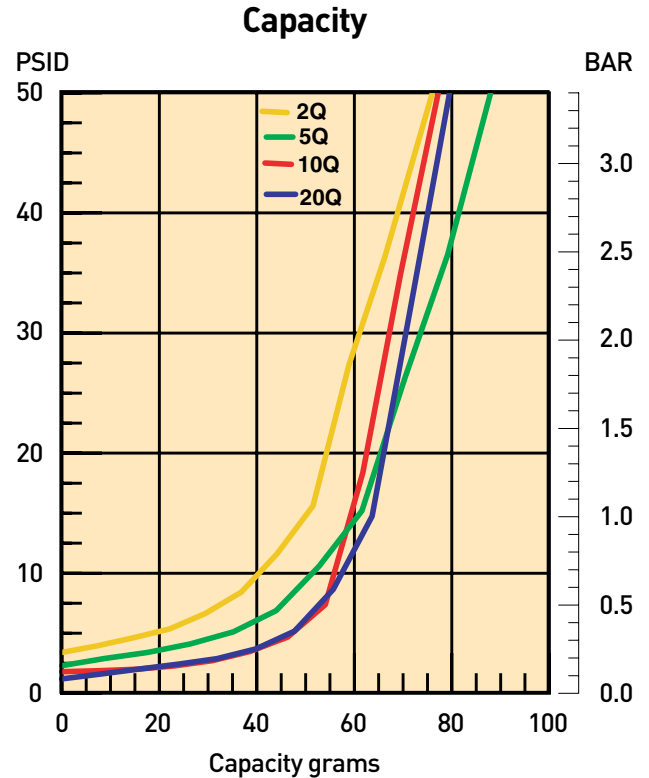
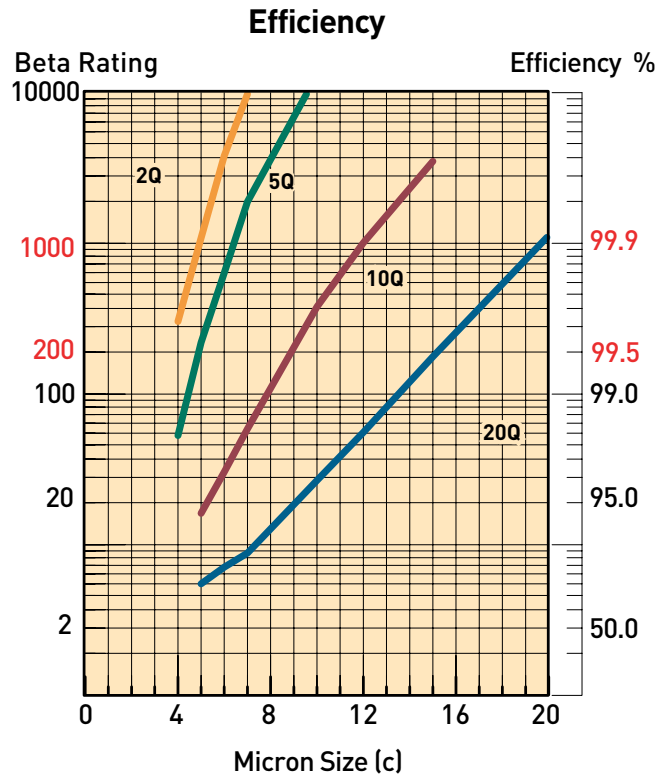

Multipass tests run @ 40 gpm to 50 psid terminal - 5mg/L BUGL

Flow vs. Pressure Loss

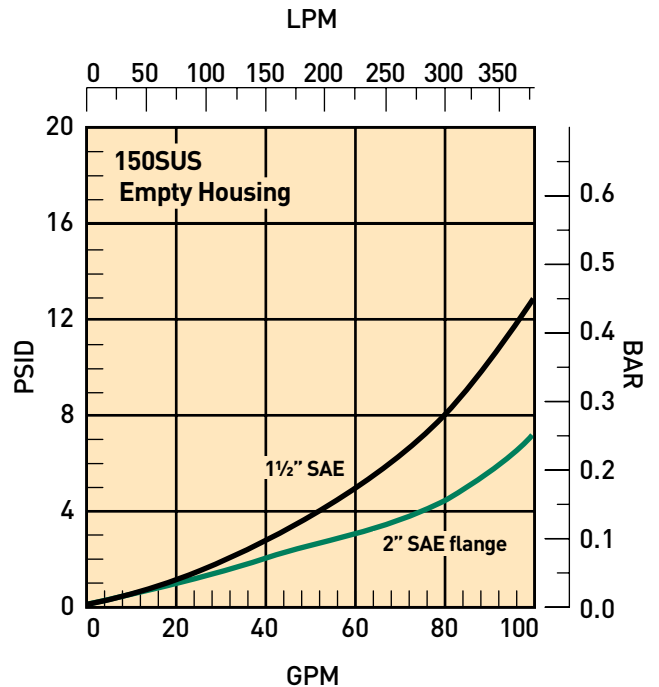
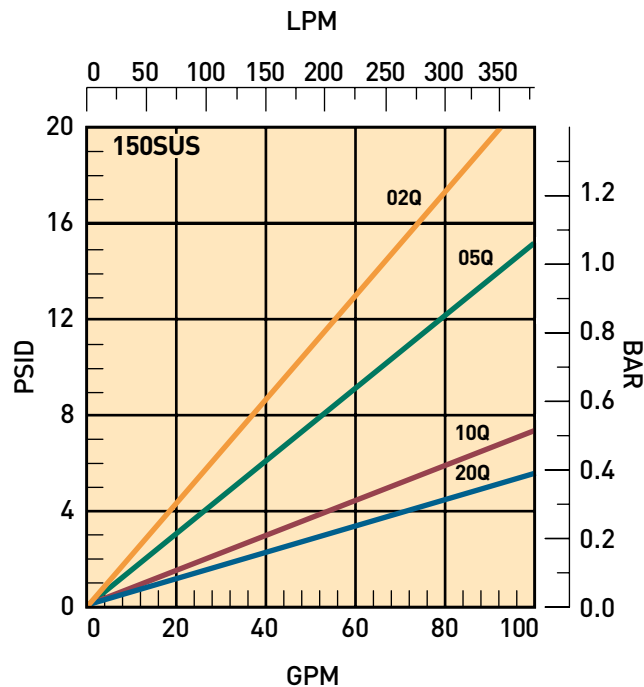

RFP-2 & ILP-2 Element Performance

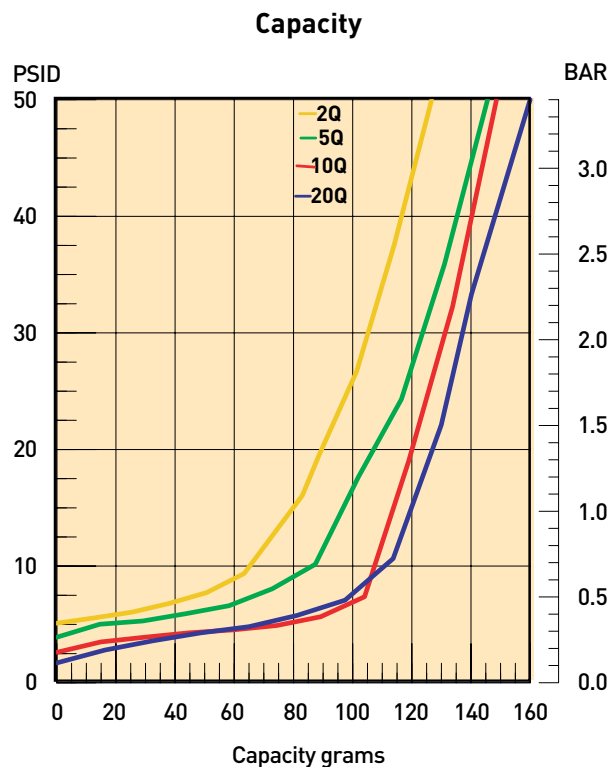
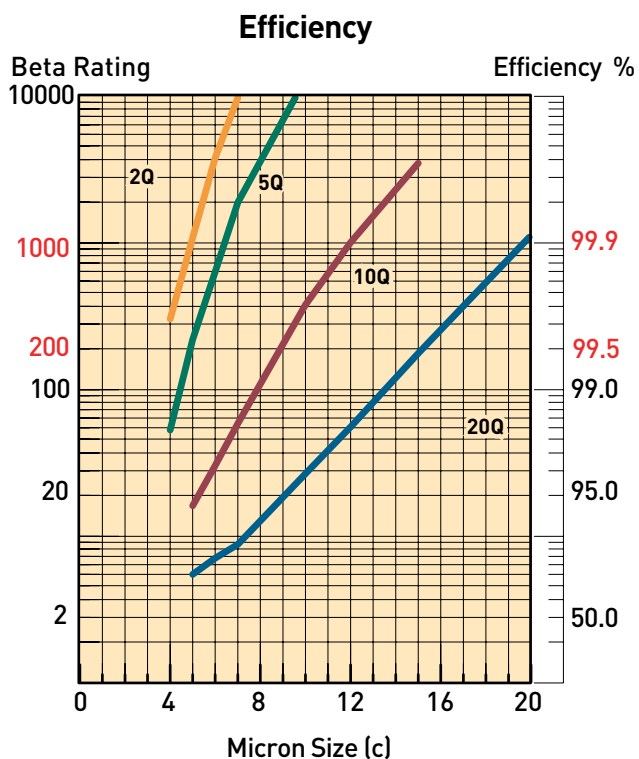

Multipass tests run @ 80 gpm to 50 psid terminal - 5mg/L BUGL

Flow vs. Pressure Loss

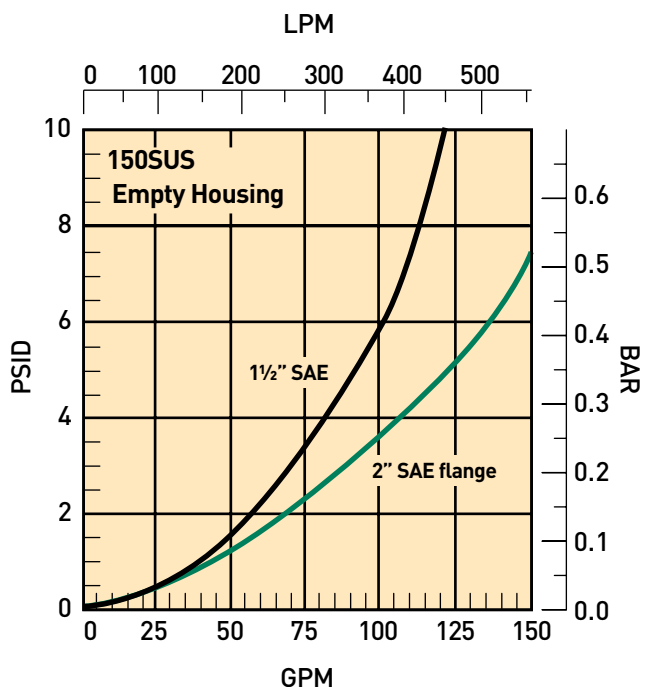
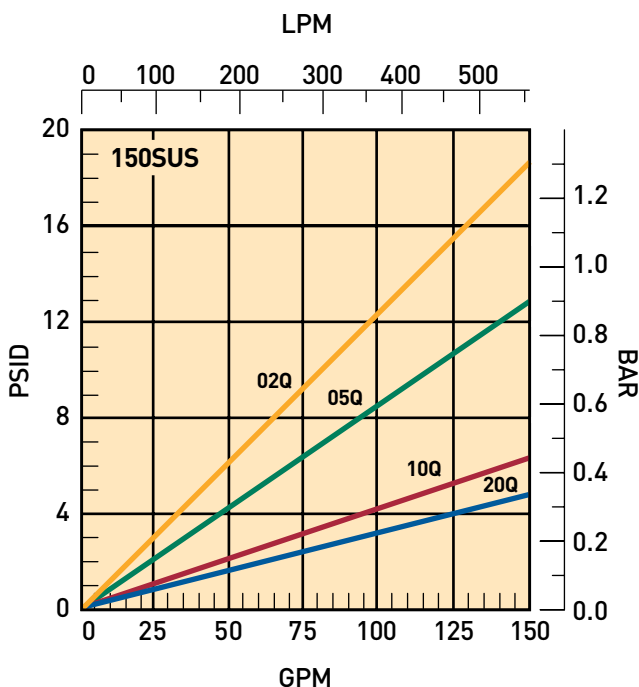

Low Pressure Filters

Moduflow™ Plus Series

Specifications: RFP, ILP

Pressure Ratings:

Maximum Allowable Operating Pressure (MAOP): 200 psi (13.8 bar)
 Design Safety Factor: 2:1
 Rated Fatigue Pressure: 150 psi (10.3 bar)

Element Burst Rating: 70 psid (4.8 bar)

Filter Materials:

Head, Cover, Flanges: die cast aluminum
 Bowl: steel

Operating Temperatures:

Nitrile: -40°F to 225°F (-40°C to 107°C)
 Fluorocarbon: -15°F to 275°F (-26°C to 135°C)

Weight (approximate):

Single: 20 lbs. (9.1 kg)
 Double: 25 lbs. (11.3 kg)

Indicators:

Visual (optional)
 Electrical (optional) 15A @ 250VAC / .5A @ 125 VDC
 Electrical ("D" option) 5A @ 250VAC / 3A @ 28 VDC

Color Coding:

White (normally closed)
 Red (normally open)
 Black (common)

Model	Dimensions: <small>mm</small> <small>inch</small>			
	A	B	C	D
RFP-1 without optional 2" fitting	$\frac{65.0}{2.56}$	$\frac{330.2}{13.0}$	—	$\frac{110.0}{4.3}$
ILP-1	$\frac{65.0}{2.56}$	$\frac{330.2}{13.0}$	N/A	$\frac{110.0}{4.3}$
RFP-1 with optional 2" fitting	$\frac{68.3}{2.69}$	—	$\frac{383.4}{15.07}$	$\frac{114.0}{4.5}$
RFP-2	$\frac{68.3}{2.69}$	$\frac{617.5}{24.31}$	$\frac{623.8}{24.56}$	$\frac{114.0}{4.5}$
ILP-2	$\frac{68.3}{2.69}$	$\frac{617.5}{24.31}$	N/A	$\frac{114.0}{4.5}$

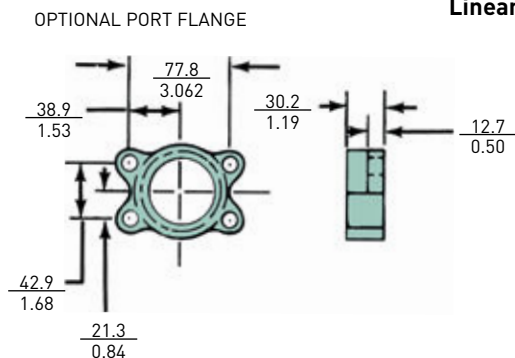
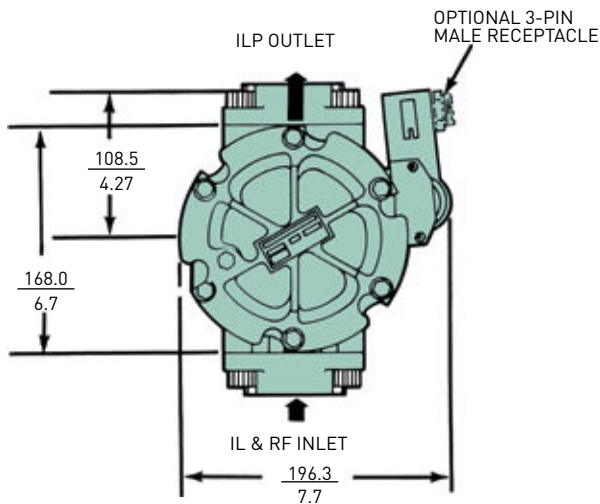

Linear Measure: millimeter
inch

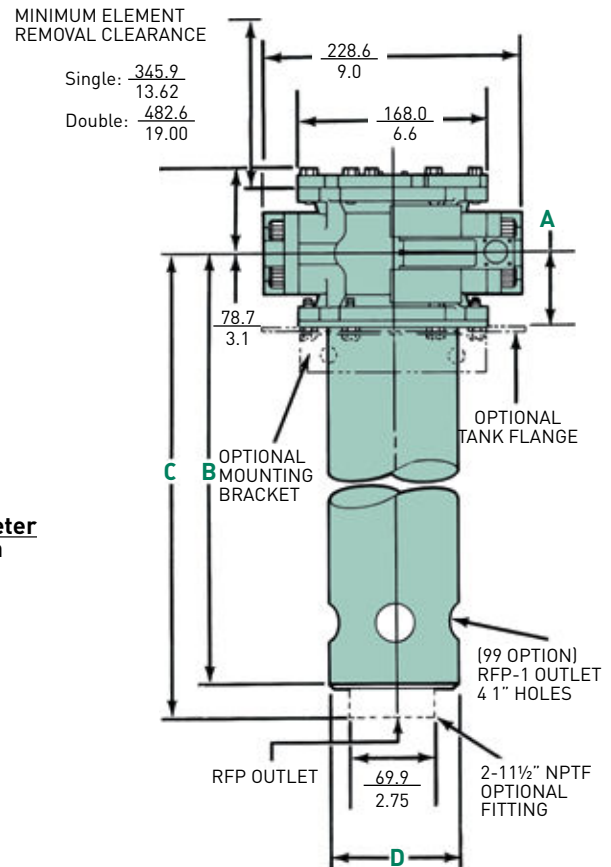

HYDAC ISO Cleanliness Levels

ISO 4406 Code

Cleanliness levels are defined by three numbers divided by slashes (/). These numbers correspond to 4, 6, and 14 micron, in that order. Each number refers to an ISO Range Code, which is determined by the number of particles for that size (4,6, & 14µm) and larger present in 1 ml of fluid. Each range is double the range below. Refer to the chart below to see the actual ranges.

Example:

larger than 4µm = 22,340

larger than 6µm = 1,950

larger than 14µm = 43

ISO Code = 22 / 18 / 13

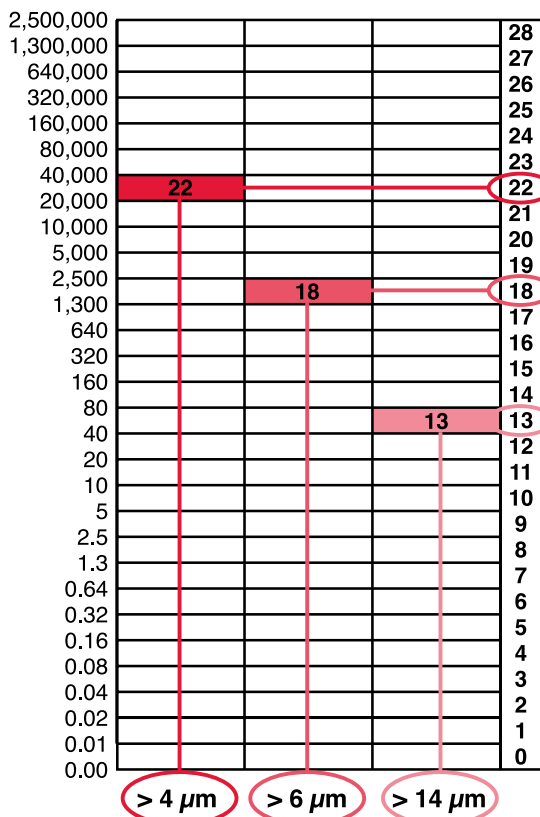

Achieving the appropriate cleanliness level in a system

The only way to achieve and maintain the appropriate cleanliness level in a hydraulic or lubrication system, is to implement a comprehensive filtration program. HYDAC offers all of the products that are needed to do just that! - They include:

Solid Contamination

- pressure filters
- return line filters
- offline filtration loops
- oil transfer units for precleaning of new oil
- portable and online contamination monitors
- reservoir breathers and filler/breathers

Water Content

- water content sensors
- reservoir breathers with silica gel desiccant
- vacuum dehydration water removal units
- water removal elements

Fluid Analysis

- bottle sampling kits
- complete analysis kits

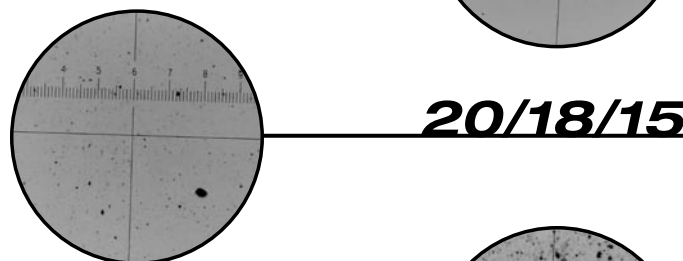
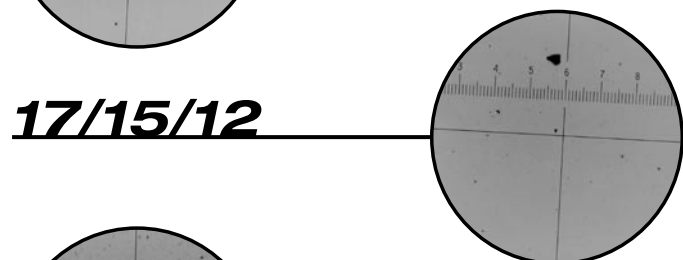
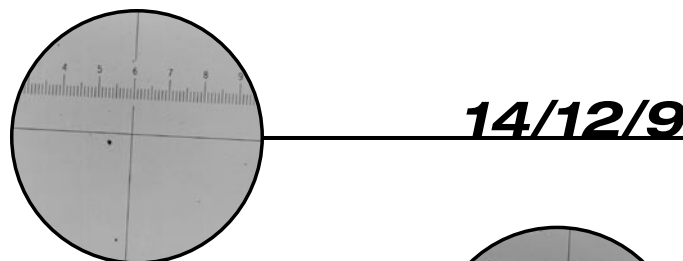

Finding the cleanliness level required by a system

1. Starting at the left hand column, select the most sensitive component used in the system.
2. Move to the right to the column that describes the system pressure and conditions.
3. Here you will find the recommended ISO class level, and recommended element micron rating.

	Low/Medium Pressure Under 2000 psi (moderate conditions)		High Pressure 2000 to 2999 psi (low/medium with severe conditions ¹)		Very High Pressure 3000 psi and over (high pressure with severe conditions ¹)	
	ISO Target Levels	Micron Ratings	ISO Target Levels	Micron Ratings	ISO Target Levels	Micron Ratings
Pumps						
Fixed Gear or Fixed Vane	20/18/15	20	19/17/14	10	18/16/13	5
Fixed Piston	19/17/14	10	18/16/13	5	17/15/12	3
Variable Vane	18/16/13	5	17/15/12	3	not applicable	not applicable
Variable Piston	18/16/13	5	17/15/12	3	16/14/11	3 ²
Valves						
Check Valve	20/18/15	20	20/18/15	20	19/17/14	10
Directional (solenoid)	20/18/15	20	19/17/14	10	18/16/13	5
Standard Flow Control	20/18/15	20	19/17/14	10	18/16/13	5
Cartridge Valve	19/17/14	10	18/16/13	5	17/15/12	3
Proportional Valve	17/15/12	3	17/15/12	3	16/14/11	3 ²
Servo Valve	16/14/11	3 ²	16/14/11	3 ²	15/13/10	3 ²
Actuators						
Cylinders, Vane Motors, Gear Motors	20/18/15	20	19/17/14	10	18/16/13	5
Piston Motors, Swash Plate Motors	19/17/14	10	18/16/13	5	17/15/12	3
Hydrostatic Drives	16/15/12	3	16/14/11	3 ²	15/13/10	3 ²
Test Stands	15/13/10	3 ²	15/13/10	3 ²	15/13/10	3 ²
Bearings						
Journal Bearings	17/15/12	3	not applicable	not applicable	not applicable	not applicable
Industrial Gearboxes	17/15/12	3	not applicable	not applicable	not applicable	not applicable
Ball Bearings	15/13/10	3 ²	not applicable	not applicable	not applicable	not applicable
Roller Bearings	16/14/11	3 ²	not applicable	not applicable	not applicable	not applicable

1. Severe conditions may include high flow surges, pressure spikes, frequent cold starts, extremely heavy duty use, or the presence of water
2. Two or more system filters of the recommended rating may be required to achieve and maintain the desired Target Cleanliness Level.



FREE Poster!

The information on these two pages is also available on our **ISO Cleanliness Guidelines** poster. Visit our web site to request your FREE copy.

www.hydacusa.com/poster

Every Company has to have a Toolbox
at Texas International Oilfield Tools.

*We provide the tools to fuel the
world!*



The terms VARCO, VARCO-BJ, and BJ are trademarks of Varco I/P, Inc., National Oilwell Varco, L.P., or their affiliates. Texas International Oilfield Tools is not an authorized distributor of any Varco I/P or NATIONAL OILWELL VARCO product. Texas International Oilfield Tools is not affiliated with Varco I/P, Inc., National Oilwell Varco, L.P., or their affiliates. Varco I/P, Inc., National Oilwell Varco, L.P., and their affiliates do not endorse any Texas International Oilfield Tools' products or replacement parts.