

FAARR

TECHNICAL MANUAL

SL-4500

4-1/2" (11.43cm) 8K Lbs.-Ft. "Slim"
Hydraulic Power Tong & Backup

- *Specifications*
- *Operation*
- *Maintenance*
- *Assembly*

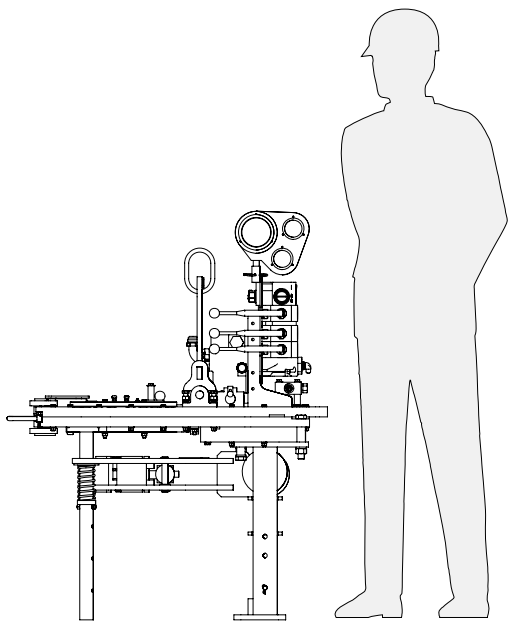

This manual covers the following models:

MODEL	REV	DESCRIPTION
80-2001-6	0	4-1/2" 6500 lb.-ft. "Slim" Tong with integrated backup & support structure, standard 2-arm sling, motor valve, backup valve, & safety door.
80-2001-8	0	4-1/2" 8000 lb.-ft. "Slim" Tong with integrated backup & support structure, standard 2-arm sling, motor valve, backup valve, lift valve, & safety door.
80-2001-10	0	4-1/2" 8000 lb.-ft. "Slim" Tong with integrated backup & support structure, short 2-arm sling, motor valve, backup valve, lift valve, & safety door.
80-2001-13	0	4-1/2" 8000 lb.-ft. "Slim" Tong with integrated backup & support structure, standard 2-arm sling, motor valve, backup valve, lift valve, safety door, & dump valve

NOTE: ***CE Marking available for all models except 80-2001-10. Some illustrations used in this manual may not exactly match your model of tong.***

PATENTED & PATENTS PENDING



***This page intentionally
left blank***

WARNINGS

A "LOAD-BEARING DEVICE" IS A CHAIN SLING, RIGID SLING, SPREADER BAR ASSEMBLY, FRAME, OR ANY OTHER DEVICE THAT BEARS THE PARTIAL OR TOTAL WEIGHT OF THE EQUIPMENT FOR WHICH THIS MANUAL HAS BEEN PRODUCED

THE LOAD-BEARING DEVICE SUPPLIED BY MCCOY DRILLING & COMPLETIONS IS DESIGNED TO SUPPORT THE EQUIPMENT DESCRIBED IN THIS MANUAL. MCCOY DRILLING & COMPLETIONS WILL NOT GUARANTEE THE ABILITY OF THE LOAD-BEARING DEVICE TO SUPPORT ANY OTHER PART, ASSEMBLY OR COMBINATION OF PARTS AND ASSEMBLIES. MCCOY DRILLING & COMPLETIONS WILL NOT GUARANTEE THE ABILITY OF THE LOAD-BEARING DEVICE TO LIFT OR SUPPORT THE EQUIPMENT DESCRIBED IN THIS MANUAL IF THERE ARE ANY MODIFICATIONS TO THE LOAD-BEARING DEVICE, OR ANY ADDITIONS TO THE EQUIPMENT DESCRIBED IN THIS MANUAL THAT ADD WEIGHT TO THE EQUIPMENT, UNLESS SUPPLIED BY MCCOY DRILLING & COMPLETIONS.

WHEN RE-ASSEMBLING LOAD-BEARING DEVICES (CHAIN SLINGS, RIGID SLINGS, BACKUP LEGS, ETC.) NOTE THAT THE ASSOCIATED FASTENERS MUST BE TIGHTENED TO THE CORRECT TORQUE SPECIFIED FOR THAT SIZE OF FASTENER (SEE SECTION 3 - OVERHAUL). ANY THREADED FASTENER IN A LOAD-BEARING DEVICE MUST BE SECURED WITH RED OR BLUE LOCTITE™.

ANY REPLACEMENT FASTENER (BOLTS, NUTS, CAP SCREWS, MACHINE SCREWS, ETC.) USED DURING MAINTENANCE OR OVERHAUL MUST BE GRADE 8 OR EQUIVALENT UNLESS OTHERWISE SPECIFIED.



***This page intentionally
left blank***

Copyright © 2009 - 2011 McCoy Corporation, including its wholly owned subsidiaries, ("McCoy"), all rights reserved. This document is the property of McCoy and is supplied as reference information for users of our products. This document and the contents within are considered confidential information, not to be disclosed, copied, transmitted, transcribed in any form, or stored on any type of data storage media without the express written consent of McCoy.

McCoy has made every effort to ensure the information contained in this document is accurate and current. This manual is intended to provide equipment operation and safety instructions for your equipment. However, McCoy does not warrant or guarantee that the information is either complete or accurate in every respect and the user of the manual should consult with its McCoy sales representative for any clarifications and updates.

The user of the manual shall protect, indemnify, and hold harmless McCoy and its directors, officers, employees, and agents from and against all liability for personal injury, death, or property damage resulting directly or indirectly from the use of the information contained in this manual.

Observance of all descriptions, information and instructions set out in this manual is the full responsibility of the user. This manual is intended for guidance and informational purposes and must be used in association with adequate training and on-the-job supervision to provide safe and effective equipment use.

It is the responsibility of the user to conform to all regulations and requirements issued by an authority or agency which may affect the operation, safety or equipment integrity, that may overrule the content of this documentation.

The user will acknowledge and obey any general legal or other mandatory regulation in force relating to accident prevention, safety, and equipment integrity.

Summary Of Revisions			
Date	Section	Page	Description Of Revision
May 2009	N/A	N/A	Initial Release
Sep 2009	Intro	1.2 & 1.3	Corrected dimensions on the specification pages
May 2010	Varies	Varies	Updated illustrations throughout to represent updated jaw retention mechanism, updated logos and branding
June 2010	Varies	Varies	Updated manual to comply with CE marking
September 2010	Appendixes	Varies	Revised appendixes
December 2011	All	All	Added table of illustrations
	2	2.13	Revised subsection 2.F.1, "Tong Rig-Up & Leveling, Suspension & Restraint"
	2	2.17	Inserted subsection 2.G.1, "Tong Operation, Operator Training"
	2	2.21	Removed Sections 2.J & 2.K, "Making Up A Joint" and "Breaking Out A Joint", inserted section 2.I, "Making & Breaking A Connection".
	3	3.1	Revised Section 3.A, "General Maintenance Safety Practices".
	3	3.1	Inserted Section 3.C, "Preventive Maintenance Practices".
	3	3.6	Inserted Subsection 3.E.2, "Safety Door Switch Adjustment".
	3	3.16	Moved "Daily Power Tong Inspection & Maintenance Checklist" to Maintenance section.
	3	3.18	Moved "Monthly Power Tong Inspection & Maintenance Checklist" to Maintenance section.
	3	3.21	Moved "Daily Backup Inspection & Maintenance Checklist" to Maintenance section.
	3	3.22	Moved "Daily Power Unit Inspection & Maintenance Checklist" to Maintenance section.
	3	3.23	Moved "Tubular Connection Equipment De-commissioning Checklist" to Maintenance section.
	3	3.26	Moved "Tubular Connection Equipment Re-commissioning Checklist" to Maintenance section.
	4	4.1 - 4.6	Revised "Troubleshooting" section.
6	ALL	Complete revision of torque measurement section	

Introduction & Specifications	Section One
Introduction & Contact Information.....	1.1
Equipment Specifications.....	1.2
Lubrication Specifications.....	1.4
Setup & Operation	Section Two
Sling / Load Bearing Device Safety.....	2.1
Major Component Identification.....	2.4
Hydraulic Schematic / Hydraulic Valve Identification.....	2.8
Hydraulic Connections.....	2.11
Tong / Backup Jaw Availability & Installation.....	2.12
Tong Rig-Up & Leveling.....	2.13
Tong Operation.....	2.17
Extreme Cold Weather Operation Procedures.....	2.20
Making & Breaking Connections.....	2.21
Maintenance	Section Three
General Maintenance Safety Practices.....	3.1
Cleaning.....	3.1
Preventive Maintenance.....	3.1
Lubrication.....	3.2
Adjustments.....	3.5
Recommended Periodic Checks.....	3.7
Disassembly & Overhaul Procedures.....	3.8
Assembly Instructions.....	3.9
Daily Inspection & Maintenance Checklist (Power Tong).....	3.16
Monthly Inspection & Maintenance Checklist (Power Tong).....	3.18
Daily Inspection & Maintenance Checklist (Backup).....	3.21
Daily Inspection & Maintenance Checklist (Power Unit).....	3.22
Tubular Connection Equipment De-commissioning Procedures.....	3.23
Tubular Connection Equipment Re-commissioning Procedures.....	3.26
Troubleshooting	Section Four
Tong Will Not Develop Sufficient Torque.....	4.1
Failure Of Jaws To Grip Pipe.....	4.3
Tong Running Too Slowly.....	4.4
General Comments.....	4.5
Assemblies And Parts	Section Five
Gear Train.....	5.2
Idler Assemblies.....	5.4
Reduction Gear Assembly (Small).....	5.6
Reduction Gear Assembly (Large).....	5.8
Rotary Assembly.....	5.10
Rotary Gear Assembly.....	5.12
Tong Body Assembly.....	5.14
Hydraulic Assembly.....	5.16
Motor Assembly.....	5.18
Brake Bands.....	5.20
Door Assembly.....	5.22
Rigid Sling Assembly.....	5.24
Backup Assembly.....	5.26
Rear Leg Assembly.....	5.28
Front Leg Assemblies.....	5.30
Torque Measurement	Section Six
Hydraulic Component Information	Section Seven

Illustration 1.A.1: SL4500 Tong & Backup.....	1.1
Illustration 1.A.2: SL4500 Dimensions.....	1.2
Illustration 2.A.1: Sling Angle.....	2.1
Illustration 2.B.1: Component Identification 01.....	2.4
Illustration 2.B.2: Component Identification 02.....	2.5
Illustration 2.B.3: Component Identification 03.....	2.6
Illustration 2.B.4: Component Identification 04.....	2.6
Illustration 2.B.5: Component Identification 05.....	2.7
Illustration 2.C.1: Hydraulic Schematic 01.....	2.8
Illustration 2.C.2: Hydraulic Component Identification 01.....	2.9
Illustration 2.C.3: Hydraulic Component Identification 02.....	2.9
Illustration 2.C.4: Hydraulic Component Identification 03.....	2.10
Illustration 2.D.1: Hydraulic Connections 01.....	2.11
Illustration 2.D.2: Hydraulic Connections 02.....	2.11
Illustration 2.E.1: Tong Jaw Removal.....	2.12
Illustration 2.E.2: Tong Jaw Die Replacement.....	2.13
Illustration 2.F.1: Master Link.....	2.14
Illustration 2.F.2: Tong Leveling.....	2.15
Illustration 2.F.3: Load Cell Configuration.....	2.16
Illustration 2.G.1: Tong Motor Control.....	2.18
Illustration 2.G.2: Lift Cylinder Control.....	2.18
Illustration 2.G.3: Backup Clamp Control.....	2.19
Illustration 2.G.4: Motor Speed Control.....	2.19
Illustration 2.I.1: Tong Suspension - Master Link.....	2.21
Illustration 2.I.2: Setting Backing Pin to "Make-up".....	2.22
Illustration 2.I.3: Backup Control.....	2.22
Illustration 2.I.4: CLAMP Pressure Gauge on Gauge Panel.....	2.23
Illustration 2.I.5: Backup Pressure Control Valve.....	2.23
Illustration 2.I.6: Unlatching & Opening Door.....	2.24
Illustration 2.I.7: Lift Cylinder Control.....	2.25
Illustration 2.I.8: Backup Control.....	2.26
Illustration 2.I.9: Motor Speed Control.....	2.26
Illustration 2.I.10: Rotation Control - Makeup.....	2.27
Illustration 2.I.11: Torque & System Pressure Gauges on Gauge Panel.....	2.27
Illustration 2.I.12: Switching Motor speed Switch To LOW SPEED.....	2.28
Illustration 2.I.13: Reversing Rotation To Free Tong Jaws.....	2.28
Illustration 2.I.14: Un-clamping Backup Jaws.....	2.29
Illustration 2.I.15: Lowering Assembly Using Lift Cylinder Control.....	2.29
Illustration 2.I.16: Setting Backing Pin To "Break-out" Mode.....	2.30
Illustration 2.I.17: Rotation Control - Break-out.....	2.31
Illustration 2.I.18: Switching Motor Speed Control To HIGH SPEED.....	2.32
Illustration 2.I.19: Releasing Tong Jaws Following Break Out & Un-threading.....	2.32
Illustration 2.I.20: Un-clamping Backup Jaws.....	2.33
Illustration 2.I.21: Lowering Assembly Using Lift Cylinder Control.....	2.33
Illustration 3.D.1: Cage Plate Roller Lubrication.....	3.2
Illustration 3.D.2: Idler Shaft Bearing Lubrication.....	3.2
Illustration 3.D.3: Reduction Gear Bearing Lubrication.....	3.3
Illustration 3.D.4: Door Pivot Shaft Lubrication.....	3.3
Illustration 3.D.5: Door Latch & Post Lubrication.....	3.4
Illustration 3.D.6: Jaw Assembly Lubrication.....	3.4
Illustration 3.D.7: Load Cell Lubrication.....	3.5
Illustration 3.E.1: Brake Band Adjustment.....	3.5
Illustration 3.E.2: Safety Door Plunger Adjustment 01.....	3.6
Illustration 3.E.3: Safety Door Plunger Adjustment 02.....	3.6
Illustration 3.E.4: Safety Door Plunger Adjustment 03.....	3.7
Illustration 3.H.1: Gearbox Cover Installation.....	3.10
Illustration 3.H.2: Idler Gear Installation.....	3.11
Illustration 3.H.3: Rotary Gear Assembly.....	3.11
Illustration 3.H.4: "Button Guide" Installation.....	3.12
Illustration 3.H.5: Main Body Fastener Placement.....	3.12
Illustration 3.H.6: Door Latch Weldment Installation.....	3.13
Illustration 3.H.7: Door Detent Installation.....	3.14
Illustration 6.A.1: Torque Gauge.....	6.1
Illustration 6.A.3: Compression Load Cell.....	6.1
Illustration 6.A.2: Tension Load Cell.....	6.1
Illustration 6.A.4: Tension Load Cell Exploded.....	6.3
Illustration 6.A.5: Compression Load Cell Exploded.....	6.4
Illustration 6.A.6: Turn Counter Encoder Mount Exploded.....	6.5

The information presented in this document will provide setup, operating, and maintenance instructions for your SL4500 tong. Due to the wide variety of operating conditions, these instructions must be considered guidelines rather than absolute operating procedures. It is the responsibility of the user to use these guidelines together with an experienced manager to develop operating procedures that conform to all policies set forth by the operating authority (ies).

IDENTIFICATION OF OF WARNINGS AND OTHER NOMENCLATURE OF IMPORTANCE USED IN THIS INSTALLATION GUIDE

Farr Canada Corp. uses three indicators to describe items of three degrees of importance.

A **HAZARD** to operators or equipment is represented by an exclamation point within a red triangle and identifies items of the highest importance. Failure to heed information identified by a **HAZARD** symbol may result in bodily injury, death, catastrophic equipment damage, or any combination of these. A **HAZARD** may also indicate the potential for dangerous environmental contamination.



This identifies a **HAZARD** to operators or equipment

A **WARNING** is represented by an exclamation point within an orange triangle, and contains information that will alert personnel to a potential safety hazard that is not life-threatening. A **WARNING** may also serve to alert the user to information critical to the correct assembly or operation of the equipment in use.



This identifies a **WARNING** to users

A **CAUTION** is represented by an exclamation point within a yellow triangle and highlights information that may aid the user during assembly or operation of your equipment. **CAUTIONS** are also used to ensure common errors are not made during assembly or operation of your equipment.



This identifies a **CAUTION** to users

Observance of the following is the full responsibility of the user:

- all descriptions, information and instructions set out in this manual
- any regulation or requirement issued by an authority or agency which may influence operation, safety or integrity of the equipment that overrules the content of this document.
- any legal or other mandatory regulation in force governing accident prevention or environmental protection.

Congratulations on the purchase of your FARR® SL4500 4-1/2" "Slim" tong. This unit will provide you with years of outstanding performance. Simple maintenance and care will extend its life and ensure years of excellent performance and reliability. The setup, operating, and maintenance instructions in this manual will assist you in giving your equipment the care it requires. Please carefully read the manual before installing and using your equipment. Replacement parts are readily available from McCoy Drilling & Completions | FARR in Edmonton Alberta. Note that many parts are transferable between FARR® tongs and backups. Should you need replacement parts, or should you experience any difficulty not covered in this manual, please contact:

McCoy Drilling & Completions | FARR

14755 121A Avenue

Edmonton, Alberta

Canada T5L 2T2

Phone: 780.453.3277

Fax: 780.455.2432

Sales Fax: 780.481.9246

Email Engineering: engFarr@mccoyglobal.com

Email Sales: salesFarr@mccoyglobal.com

Website: <http://www.mccoyglobal.com/index.php/drilling-completions>



ILLUSTRATION 1.A.1: SL4500 TONG & BACKUP

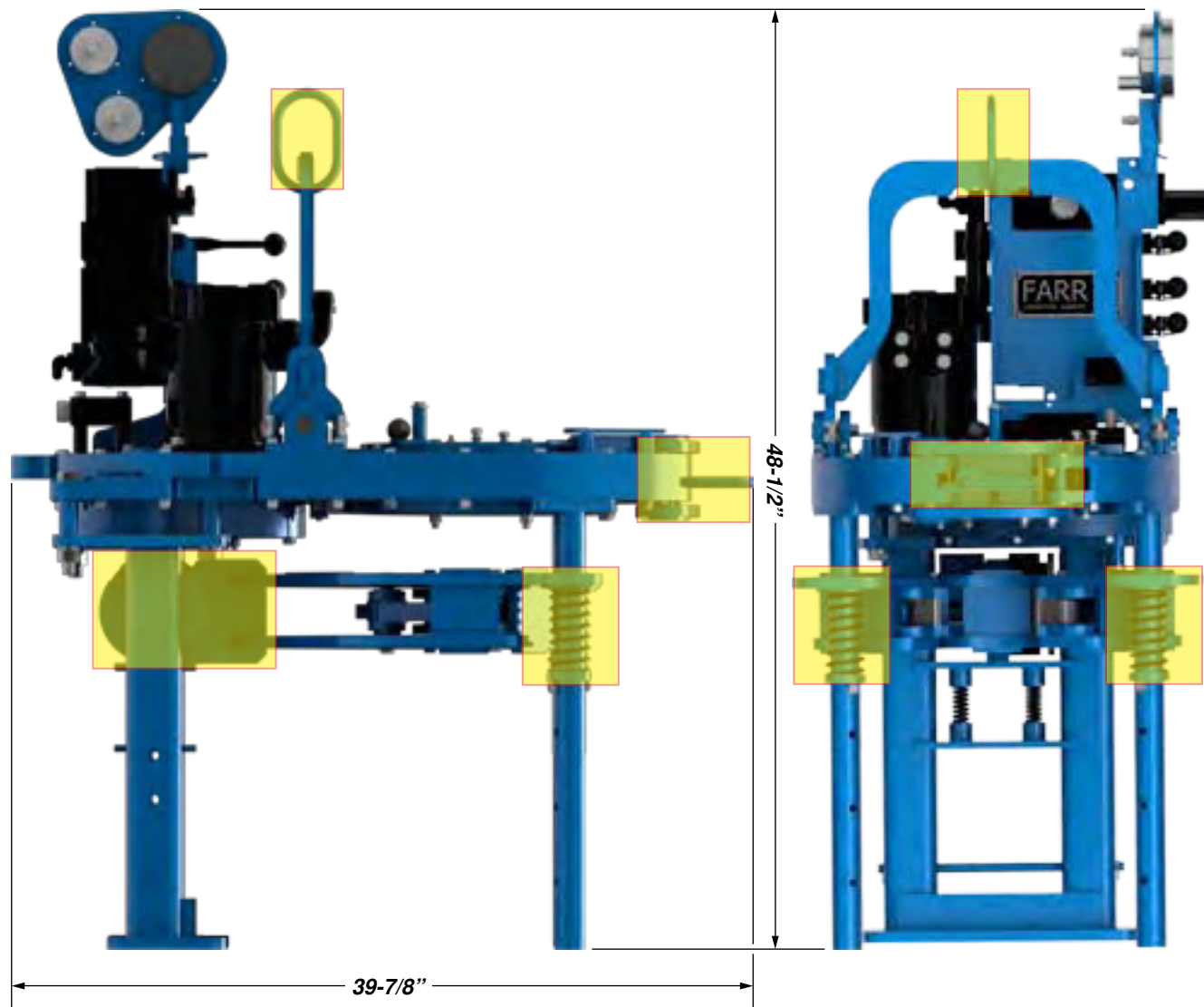

ILLUSTRATION 1.A.2: SL4500 DIMENSIONS

PLEASE NOTE: AREAS SHOWN HIGHLIGHTED ARE POTENTIAL PINCH/HAZARD AREAS. EXERCISE CAUTION AROUND THESE AREAS DURING TONG OPERATION.

Torque Table (Low Torque) **

Pressure (PSI)	Hi Speed (lbs.-ft.)	Lo Speed (lbs.-ft.)
1000	660	2300
1500	1060	3700
2000	1485	5200
2500	1885	6500

MAXIMUM RATED TORQUE: 6500 LBS.-FT.

Speed Table (Low Torque) **

Flow (US GPM)	Lo Speed (RPM)	Hi Speed (RPM)
10	8	28
20	16	55
40	32	111
60	48	166

Torque Table (High Torque) **

Pressure (PSI)	Hi Speed (lbs.-ft.)	Lo Speed (lbs.-ft.)
1000	1400	2800
1500	2300	4600
2000	3150	6300
2500	4000	8000

MAXIMUM RATED TORQUE: 8000 LBS.-FT.

Speed Table (High Torque) **

Flow (US GPM)	Lo Speed (RPM)	Hi Speed (RPM)
10	6	13
20	13	25
40	26	51
60	39	76

**** These are ideal values. Actual achieved torque is highly dependant upon tong efficiency and final position of rotary gear when full torque load is reached.**

- Max. Hydraulic Requirements:** 60 GPM (227.1 LPM) / 3000 PSI (20.684 MPa)
- Max Hydraulic Fluid Temp:** 82°C
- Operating Temperature:** -20°C to +40°C
- Length:** 39-7/8" / 101.3 cm
- Overall Width:** 20" / 50.8 cm
- Height:** 48-1/2" / 123.2 cm
- Torque arm length:** 24-3/4 inches / 62.9 cm (Tong only) (Center Line of Pipe Center Line of Anchor Handle)
18 inches / 45.7 cm (Tong & Backup)
- Weight (Approximate):** 600 lb. / 273 kg. (Tong Only)
1000 lb. / 444.4 kg. (Tong & Backup)
- Jaw Range:** 1.90" (48.25 mm) - 5.00" (127 mm) Diameter Pipe
- Jaws available (inches):** See Pp. 2.13
- Max Sound Level:** 97 dB A @ 1m
96 dB C @ 1m



REPLACEMENT FASTENERS (BOLTS, NUTS, CAP SCREWS, MACHINE SCREWS, ETC.) MUST BE GRADE 8 OR EQUIVALENT UNLESS OTHERWISE SPECIFIED.

Use an EP synthetic grease that meets or exceeds the following specifications:

Thickener	Lithium Complex
NLGI consistency grade	2
NLGI performance grade	GC-LB
Penetration - ASTM D 217 (25°C [77°F] 0.1 mm) worked 60 strokes	265-295 minimum
Dropping point, °F[°C] - ASTM D2265	550 [288] minimum
High temperature life, hours - ASTM D 3527	160 minimum
Oxidation stability, psi - ASTM D 942	(100 hr/300 hr) 0/3
Water washout, percent - ASTM D 1264	1.8 max
Rust and corrosion - ASTM D 1743	pass
Oil separation, percent loss - ASTM D 1742 (24 hours, 25°C [77°F])	1.1 max
Leakage, g lost - ASTM D 4290	1.0 max
Four ball wear test, mm scar - ASTM D 2266	0.40 max
Fretting wear, mg - ASTM D 4170	3.4 max
Four ball EP, kgf - ASTM D 2596	
Weld point	400 minimum
Load wear index	50 minimum
Timken OK load test, lbs - ASTM D 2509	50
Low temperature torque, N*m - ASTM D 4693 (-40°C [-40°F])	1.3 max
LT-37 pumpability, g/min (60°F/0°F [16°C/-18°C])	360/7
Copper corrosion - ASTM D 4048	1B
Disc brake wheel bearing specifications	
Ford ESA-M1C 198A	Yes
Chrysler MS-3701	Yes
Oil viscosity: 40°C [104°F], cSt	151
100°C [212°F], cSt	19.2
Flash point, °F[°C] - ASTM 92	450[232]

Use a premium quality hydraulic fluid that meets or exceeds the following specifications:

Typical Density (kg/m3)	878
Viscosity - cSt @ 40 °C	68.8
- cSt @ 100 °C	8.7
Viscosity Index	97
Pour Point °F [°C]	-22 [-30]
Flash Point °F [°C]	432 [222]
Colour, ASTM	1.5
Neutralization Number	0.40
Rust Protection - Distilled Water	No Rust
- Sea Water	No Rust
Hydrolytic Stability - Cu Mass Loss, mg/cm2	0.04
Copper Corrosion Test	1A
Filterability: Denison - Wet & Dry	Pass
Afnor - Wet & Dry	Pass
Cincinatti Milacron Spec Approved	P69
Denison HF-0:	Approved
Denison P-46 Piston Pump:	Pass
Denison T6C Vane Pump:	Pass
Vickers 35VQ25 Vane Pump Test:	Pass
104/105C Vane Pump Test:	No Data Available
Vane pump test total ring and vane wear, mg.	<10
Oxidation Stability	
Turbine Oil Stability Test Life, hours	2500+
Rotary Bomb Oxidation Test, minutes	325
FZG Spur Gear Test, Failure Load Stage (FLS)	12

Adequate setup and proper hydraulic connections are essential in ensuring reliable operation of your tong. For best results and long term reliability, read and obey the start-up instructions in this section.



DO NOT ACCESS ROTATING COMPONENTS UNLESS HYDRAULIC POWER SUPPLY HAS BEEN DEACTIVATED OR ISOLATED.

A CLEARLY IDENTIFIED REMOTE POWER PACK EMERGENCY STOP MUST BE INSTALLED IN THE IMMEDIATE VICINITY OF THE TONG OPERATOR.

A. SLING / LOAD BEARING DEVICE SAFETY



THE SUPPLIED LOAD-BEARING DEVICE (CHAIN SLING, RIGID SLING, SPREADER BAR ASSEMBLY, FRAME, OR ANY OTHER DEVICE THAT BEARS THE PARTIAL OR TOTAL WEIGHT OF THE EQUIPMENT DESCRIBED IN THIS MANUAL) HAS BEEN SPECIFIED OR DESIGNED TO SUPPORT THE EQUIPMENT DESCRIBED IN THIS DOCUMENT. FARR WILL NOT GUARANTEE THE ABILITY OF THE LOAD-BEARING DEVICE TO SUPPORT ANY OTHER PART, ASSEMBLY OR COMBINATION OF PARTS AND ASSEMBLIES, OR ANY ADDITIONS TO THE EQUIPMENT DESCRIBED IN THIS MANUAL THAT ADD WEIGHT TO THE EQUIPMENT, UNLESS SUPPLIED BY FARR CANADA CORP..

FARR CANADA CORP. DOES NOT GUARANTEE THE INTEGRITY OF MODIFIED OR DAMAGED LOAD-BEARING DEVICES, UNLESS THOSE MODIFICATIONS ARE PERFORMED BY FARR CANADA CORP..

McCoy Drilling & Completions recommends following an industry-accepted standard such as OSHA, ASME B30.9-2006, or manufacturer's guidelines when performing any rigging and overhead lifting. Use by untrained persons is hazardous. Improper use will result in serious injury or death. Do not exceed rated capacity. Slings will fail if damaged, abused, misused, overused, or improperly maintained.

- Only grade 80 or grade 100 alloy chain should be used for overhead lifting applications.
- Working Load Limit (WLL) is the maximum allowable load in pounds which may be applied to the load-bearing device, when the device is new or in "as new" condition, and when the load is uniformly and directly applied. The WLL must never be exceeded.
- Working Load Limit (WLL) is the maximum working load for a specific minimum sling angle, measured from the horizontal plane. The Working Load Limit is identified on the sling.
- The Working Load Limit or Design factor may be affected by wear, misuse, overloading, corrosion, deformation, intentional alterations, sharp corner cutting action and other use conditions.
- Shock loading and extraordinary conditions must be taken into account when selecting alloy chain slings.
- See OSHA Regulation for Slings 1910.184, ANSI/ASME B30.9-"SLINGS", ANSI/ASME B30.10-"HOOKS" and ANSI/AMSE B30.26 "RIGGING HARDWARE" for additional information.



THE MINIMUM SLING ANGLE (THE ANGLE OF THE LEG OF THE SLING MEASURED FROM THE HORIZONTAL) MUST NEVER FALL LOWER THAN THE ANGLE SPECIFIED FOR THE SLING IN USE

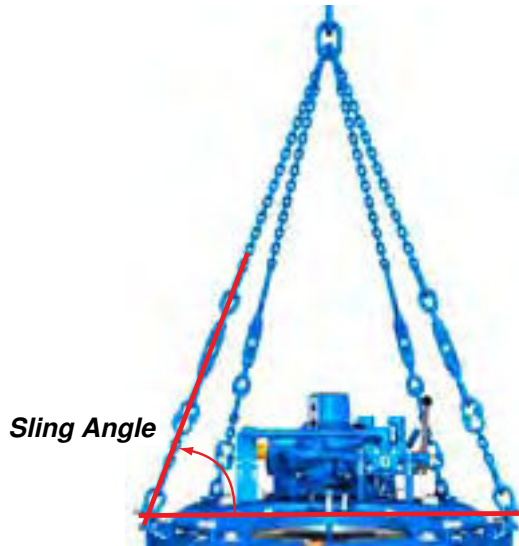

ILLUSTRATION 2.A.1: SLING ANGLE

1. Inspection Of Slings

Farr Canada Corp. strongly recommends the following practices:

A complete inspection of new load-bearing devices and attachments shall be performed by a qualified, designated person prior to initial use. Each link and component shall be examined individually, taking care to expose and examine all surfaces including the inner link surface. The sling shall be examined for conditions such as those listed in the removal criteria below. In addition, daily inspection of slings, fastenings and attachments shall be performed by a designated person. If damage or defects are found at either inspection, the damaged or defective component shall be quarantined from service until it can be properly repaired or replaced.

Removal Criteria:

A load-bearing device shall be removed from service if conditions such as the following are present:

- Missing or illegible sling identification.
- Cracks or breaks
- Evidence of tampering is seen - sling tag has been modified or obscured, or tamper-proof nuts are missing.
- Signs of impact on load-bearing components, including spreader bars, lifting lugs, rigid slings & rigid sling weldments, and legs & leg mounts.
- Broken or damaged welds.
- Excessive wear, nicks, or gouges. Refer to the chart below to ensure minimum thickness on chain links supplied is not be below the values listed:

Minimum Allowable Chain Link Thickness at Any Point			
Nominal Chain Size		Minimum Thickness	
Inches	MM	Inches	MM
7/32	5.5	0.189	4.80
9/32	7	0.239	6.07
5/16	8	0.273	6.93
3/8	10	0.342	8.69
1/2	13	0.443	11.26
5/8	16	0.546	13.87
3/4	20	0.687	17.45
7/8	22	0.750	19.05
1	26	0.887	22.53
1-1/4	32	1.091	27.71
Refer To ASME B30.9			

- Stretched, bent, twisted, or deformed chain links or components.
- Evidence of heat damage.
- Excessive pitting or corrosion.
- Lack of ability of chain or components to hinge (articulate) freely.
- Weld splatter.
- For hooks, removal criteria as stated in ASME B30.10
- Other conditions, including visible damage, that cause doubt as to the continued use of the sling.

Inspect all lugs and fixing points for signs of elongation and/or bending, or for material build-up around the hole. Repair or replace components that appear distorted. Ensure all hardware is tight and in good condition. Replace missing hardware if necessary. All hardware must be free of rust and corrosion.

Additional inspections shall be performed during sling use where service conditions warrant. Periodic inspection intervals shall not exceed one year. The frequency of periodic inspections should be based on:

- Frequency of use of the load-bearing device.
- Severity of service conditions
- Nature of lifts being made
- Experience gained on the service life of load-bearing devices used in similar circumstances.

Guidelines for the interval are:

- Normal Service: Yearly
- Severe Service: Monthly to quarterly
- Special Service: As recommended by a qualified person

Units designed and manufactured in accordance with EN 12079 and DNV 2.7-1 should be tested and examined in accordance with the following schedule of examination and test. The user of the load-bearing device shall place a permanent placard or plate upon which the type and date of the last test shall be recorded. To avoid confusion, the plate shall not carry the date of the next test or examination, only the most recent.

Test / Examination				
TIME / INTERVAL	LIFTING TESTS ¹	NON-DESTRUCTIVE EXAMINATION (NDE) OF LIFTING POINTS	THOROUGH VISUAL EXAMINATION	SUFFIX TO BE MARKED ON PLATE ATTACHED TO UNIT
Initial Certification By Farr / Superior	YES	YES	YES	T
Interval Not Exceeding 12 Months	At the discretion of inspection body	At the discretion of inspection body	YES	T or VN ³
Interval Not Exceeding 60 Months	At the discretion of inspection body	YES	YES	T or VN
Following Substantial Repair or Alteration ⁴	YES	YES	YES	T

1. Lifting test as per S 7.3 BS EN 12079 or DNV 2.7-1 May 1995
 2. T = Proof Test, non-destructive examination; VN = non destructive examination and visual examination; V = visual examination.
 3. Dependant upon whether non-destructive examination has been carried out.
 4. For the purposes of this standard, a substantial repair or modification is defined as any repair and/or modification that has been carried out which may, in the opinion of the inspection body, affect the load-bearing elements of the container or lifting device, or elements that contribute directly to its structural integrity.



IF MECHANICAL DAMAGE IS SEEN OR SUSPECTED ON A LOAD-BEARING DEVICE, OR IF THE LOAD-BEARING DEVICE HAS BEEN OVERLOADED, IT MUST BE REMOVED FROM SERVICE AND QUARANTINED UNTIL RECERTIFIED

Written records of the most recent periodic inspection shall be maintained, and shall include the condition of the sling.

2. Proper Use Of Load-Bearing Devices

Whenever any load-bearing device is used, the following practices shall be observed.

- Load-bearing devices that are damaged or defective shall not be used.
- Slings shall not be shortened with knots or bolts or other makeshift devices.
- Sling legs shall not be kinked.
- Load-bearing devices shall not be loaded in excess of their rated capacities.
- Slings shall be securely attached to their load.
- Load-bearing devices shall be protected from snagging, and shall not be further obstructed by any object.
- Suspended loads shall be kept clear of all obstruction.
- All employees shall be kept clear of loads about to be lifted and of suspended loads.
- Hands or fingers shall not be placed between the sling and its load while the sling is being tightened around the load.
- Shock loading is prohibited.
- Do not stand directly under a load during lifting.

3. Storage Of Load-Bearing Devices

Proper storage of out-of-service load bearing devices is important to ensure full integrity of the device once it is returned to service. Farr recommends observing the following practices:

- Wipe off all excess grease. Use a solvent-based cleaner on rags to wipe all external surfaces to remove residual grease or hydraulic fluid. Once the outside surfaces have been de-greased, wipe all external surfaces with clean water to remove residual solvent.
- Farr recommends that an anti-corrosive agent such as Tectyl® 506 be applied to all external surfaces. Refer to manufacturer data sheets for proper application and safety information. Allow the anti-corrosive coating ample time to dry - refer to manufacturer data sheets for drying times at room temperature.
- Store in a clean, dry location. When returning to service, note that a full inspection of the device must be performed.

B. MAJOR COMPONENT IDENTIFICATION

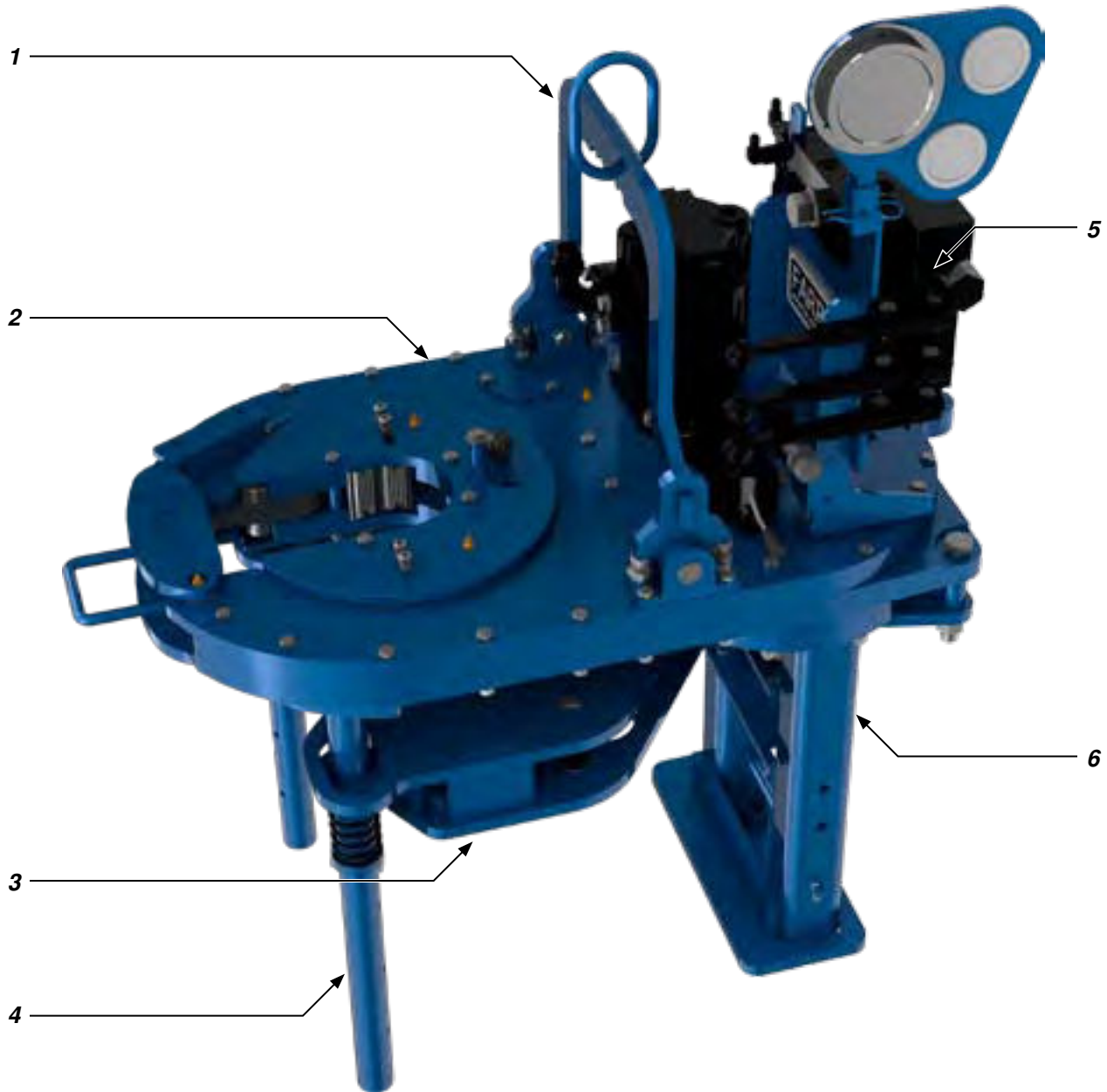

ILLUSTRATION 2.B.1: COMPONENT IDENTIFICATION 01

Item	Description
1	Rigid Sling
2	Tong
3	Backup
4	Front Leg Assembly
5	Hydraulic Valve Assembly & Mounting Plate
6	Rear Leg Assembly

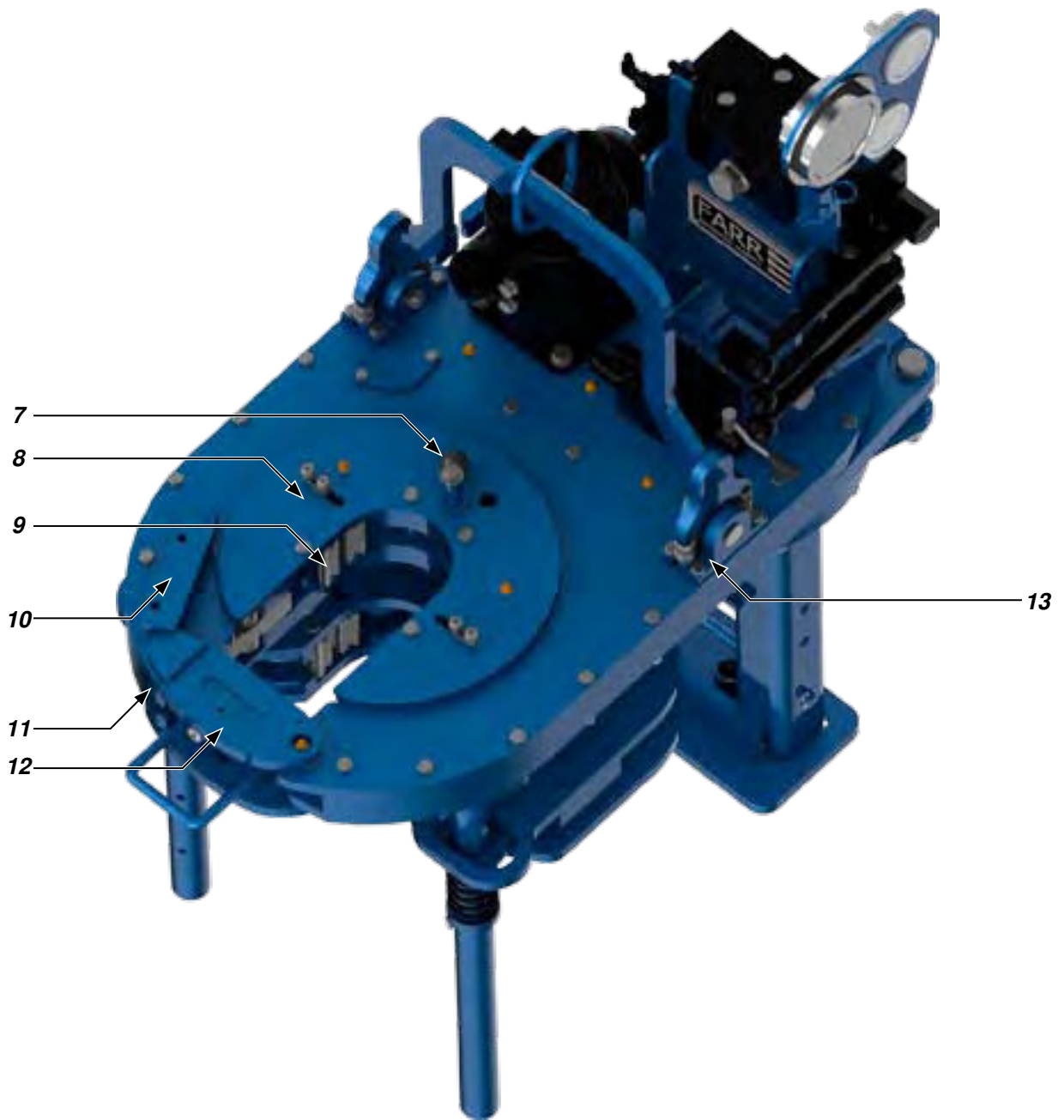

ILLUSTRATION 2.B.2: COMPONENT IDENTIFICATION 02

Item	Description
7	Backing Pin Assembly
8	Cage Plate Assembly
9	Tong Jaws with Die Inserts
10	Safety Door Plunger & Guard
11	Tong Door Latch
12	Tong Door
13	Tong Leveling Adjustment

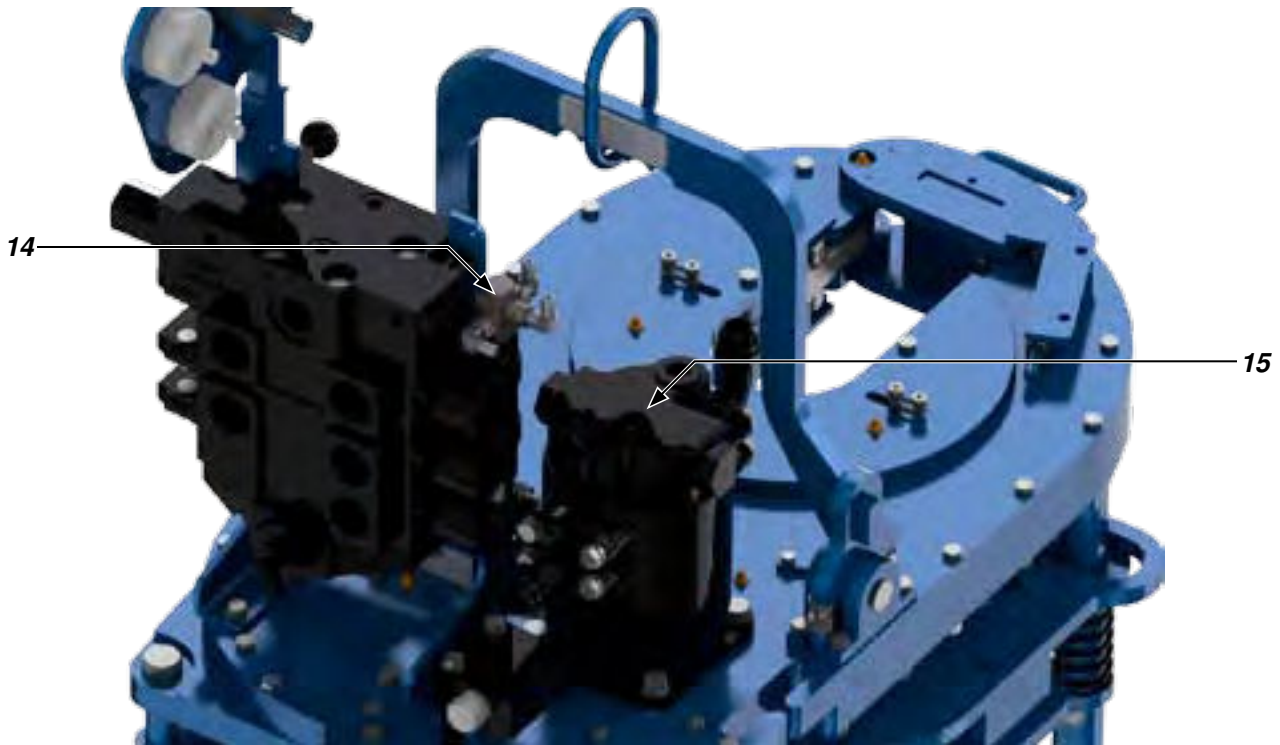

ILLUSTRATION 2.B.3: COMPONENT IDENTIFICATION 03

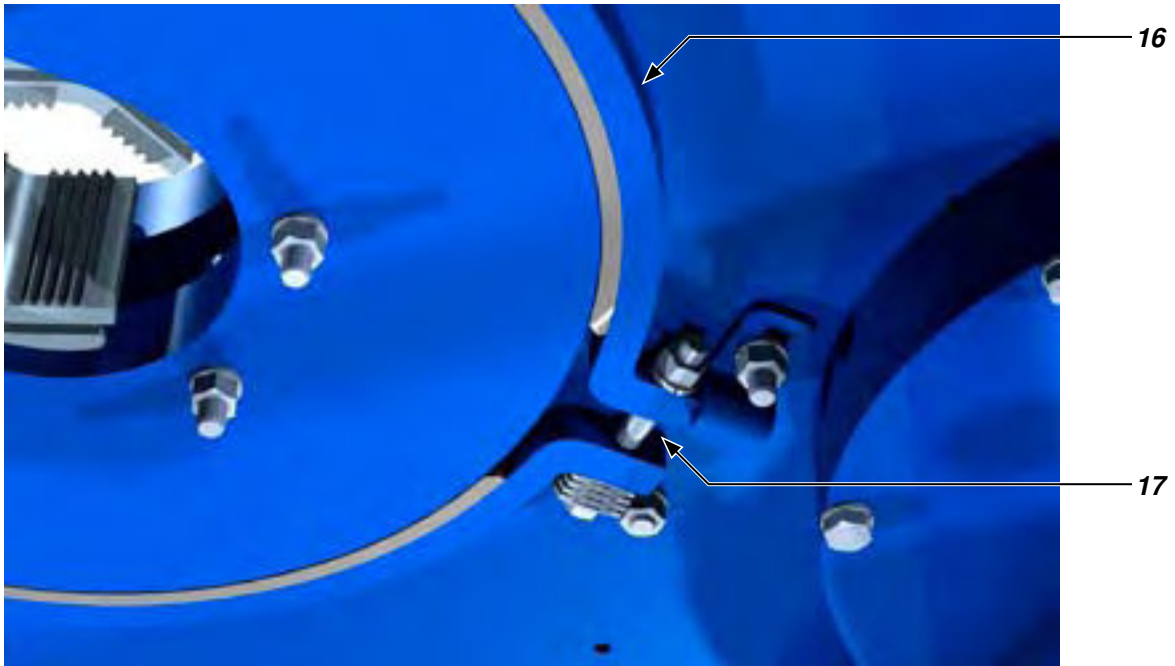

ILLUSTRATION 2.B.4: COMPONENT IDENTIFICATION 04

Item	Description
14	Safety Door Valve
15	Hydraulic Motor
16	Brake Band
17	Brake Band Adjustment

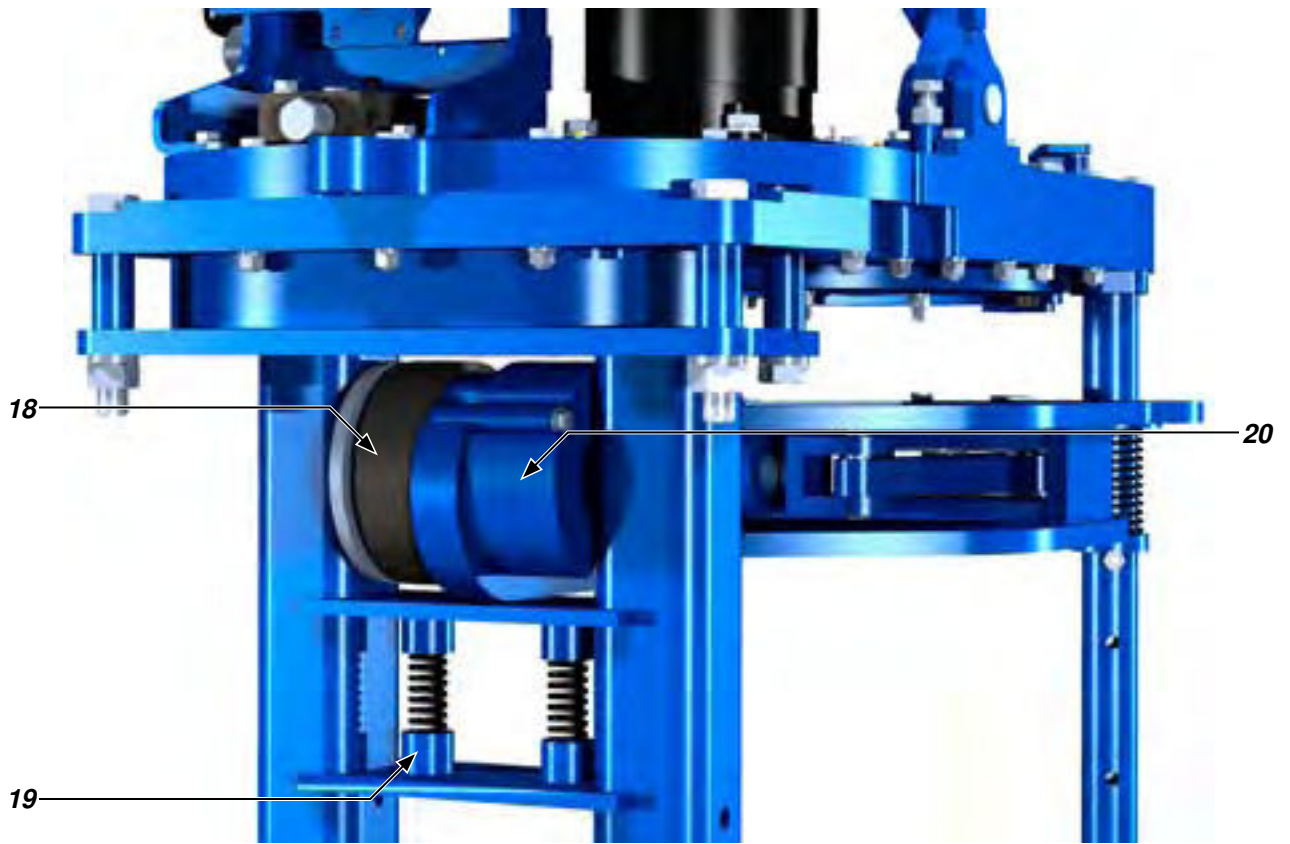

ILLUSTRATION 2.B.5: COMPONENT IDENTIFICATION 05

<i>Item</i>	<i>Description</i>
18	Compression Load Cell
19	Rear Backup Float Spring Assembly
20	Load Cell Spacer

C. HYDRAULIC SCHEMATIC & VALVE IDENTIFICATION

The following hydraulic schematic illustrates the hydraulic controls of a fully equipped tong and backup assembly. Your specific equipment may or may not have all hydraulic controls as illustrated.

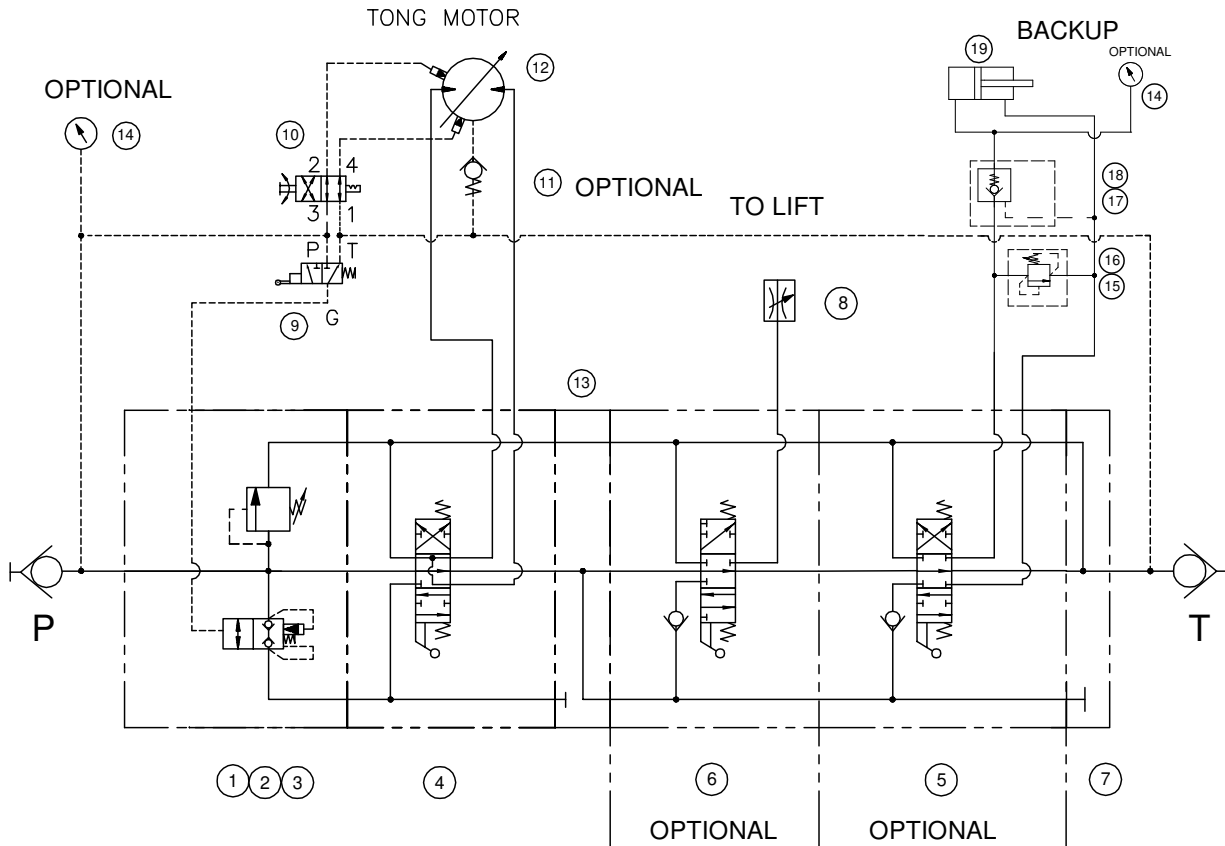

ILLUSTRATION 2.C.1: HYDRAULIC SCHEMATIC 01

Item	Description	Part Number	Page
1	Inlet Valve c/w safety door cartridge	101-3927A	2.10
2	Relief Valve (type varies with model)		2.10
3	Pilot-To-Open Valve, Sun LKHC-XDN	08-1625	2.11
4	Motor Section, DVA35-MA8, 4-WAY SAE PORTS	10-9014	2.10
5	Backup Section, DVA35-DA8, SAE PORTS	10-9019	2.10
6	Lift Cylinder Section, DVA35-SA8, (1" ORB PORT)	10-9015	2.10
7	Outlet Section, DVA35-TR99, SAE PORT	10-0086	2.10
8	Flow Control Valve, Parker N800S (Not Shown)	08-9062	Not Shown
9	Safety Door Switch	08-0337	2.11
10	Motor Shift Valve, Bailey ED Series 220-906	10-9035	2.10
11	Check Valve	08-9022	2.11
12	Rineer GA15-13/6.5 Hydraulic Motor (High Torque Version)	87-0008	2.11
	Rineer GA15-10.5/3 Hydraulic Motor (Low Torque Version)	87-0010	2.11
13	DVA35 Transition Plate	101-3935	2.10
14	3000 psi Pressure Gauge	02-0246	Not Shown
15	Valve Body	08-1327	2.11
16	Pilot-To-Open Check Valve, Sun CKEB-XCN	08-0481	2.11
17	Relief Valve. Sun RPCC-KAN	08-1749	Not Shown
18	Relief Valve Block, Sun AAI	08-1750	Not Shown
19	Backup Clamp Cylinder (Inside Backup)	101-4336	2.10

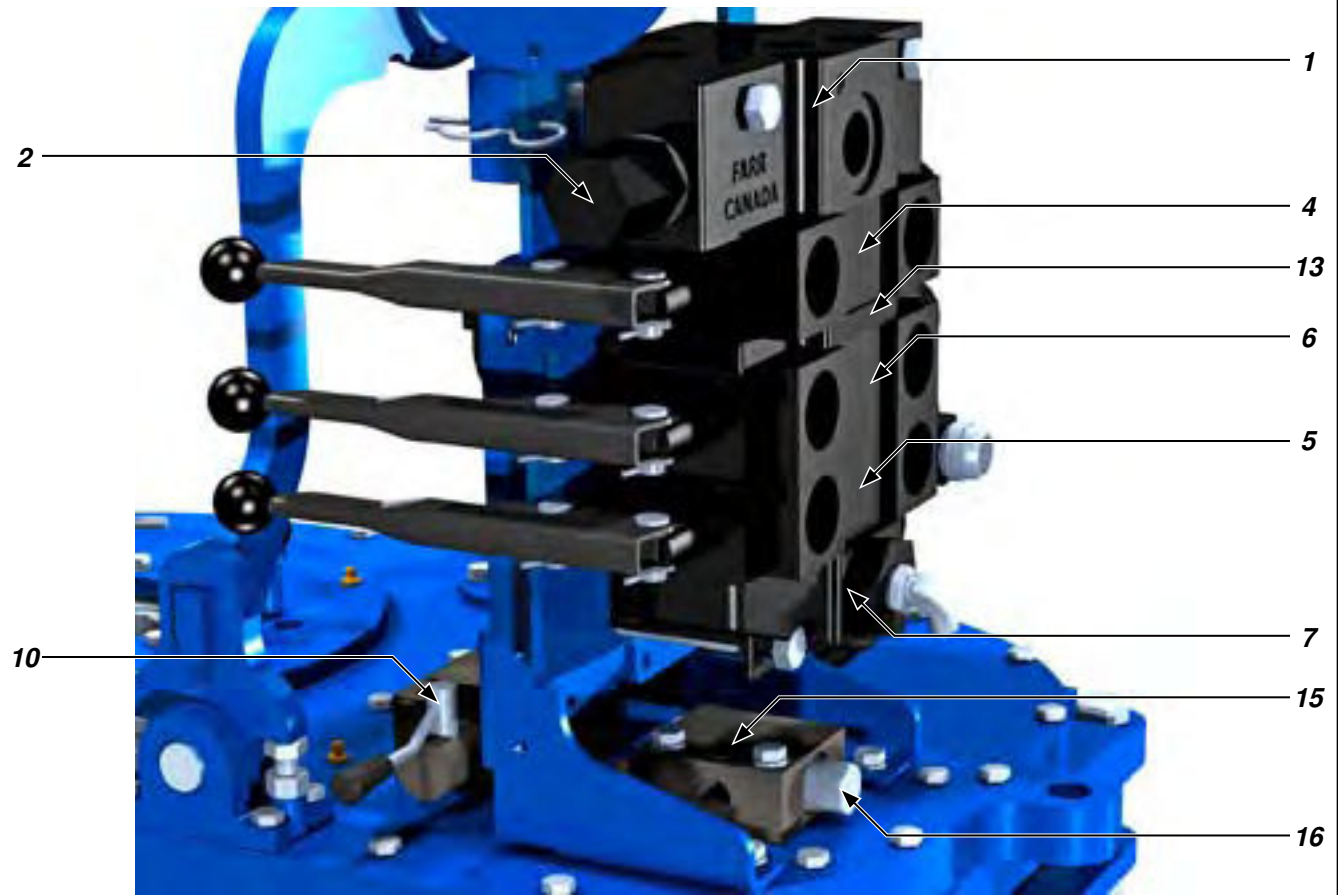

ILLUSTRATION 2.C.2: HYDRAULIC COMPONENT IDENTIFICATION 01

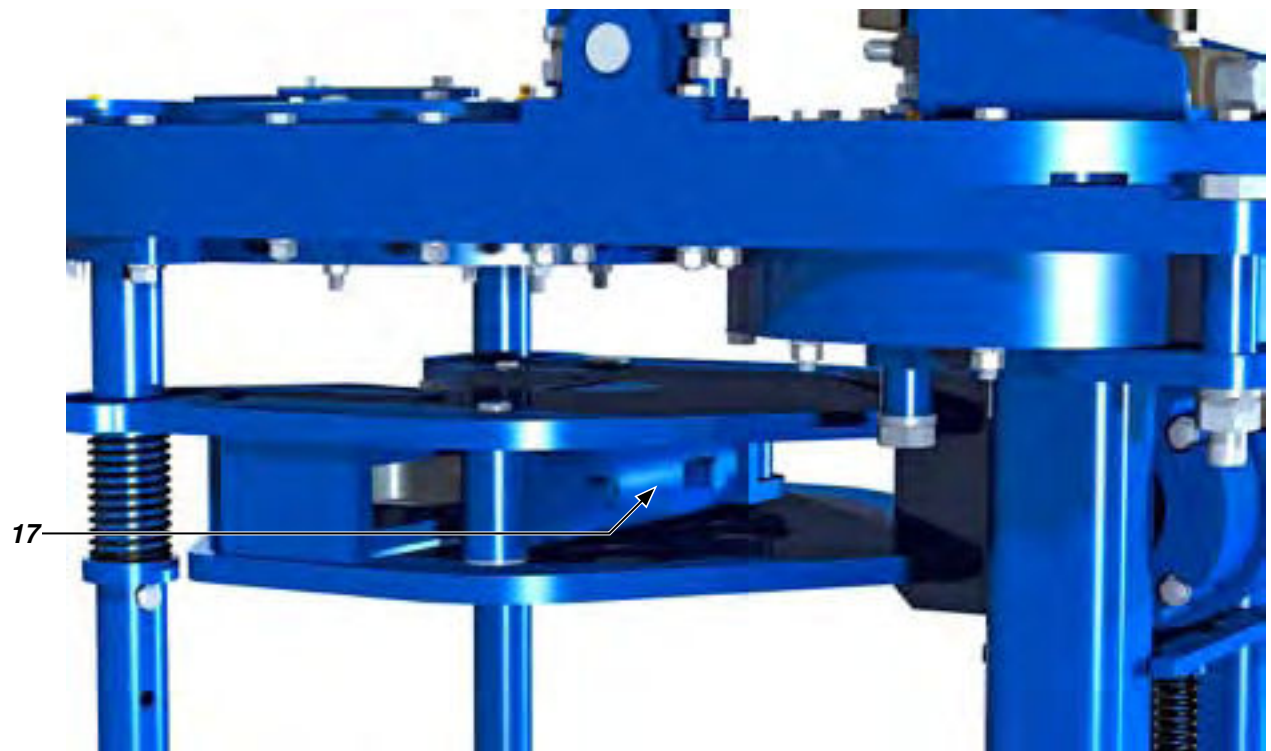

ILLUSTRATION 2.C.3: HYDRAULIC COMPONENT IDENTIFICATION 02

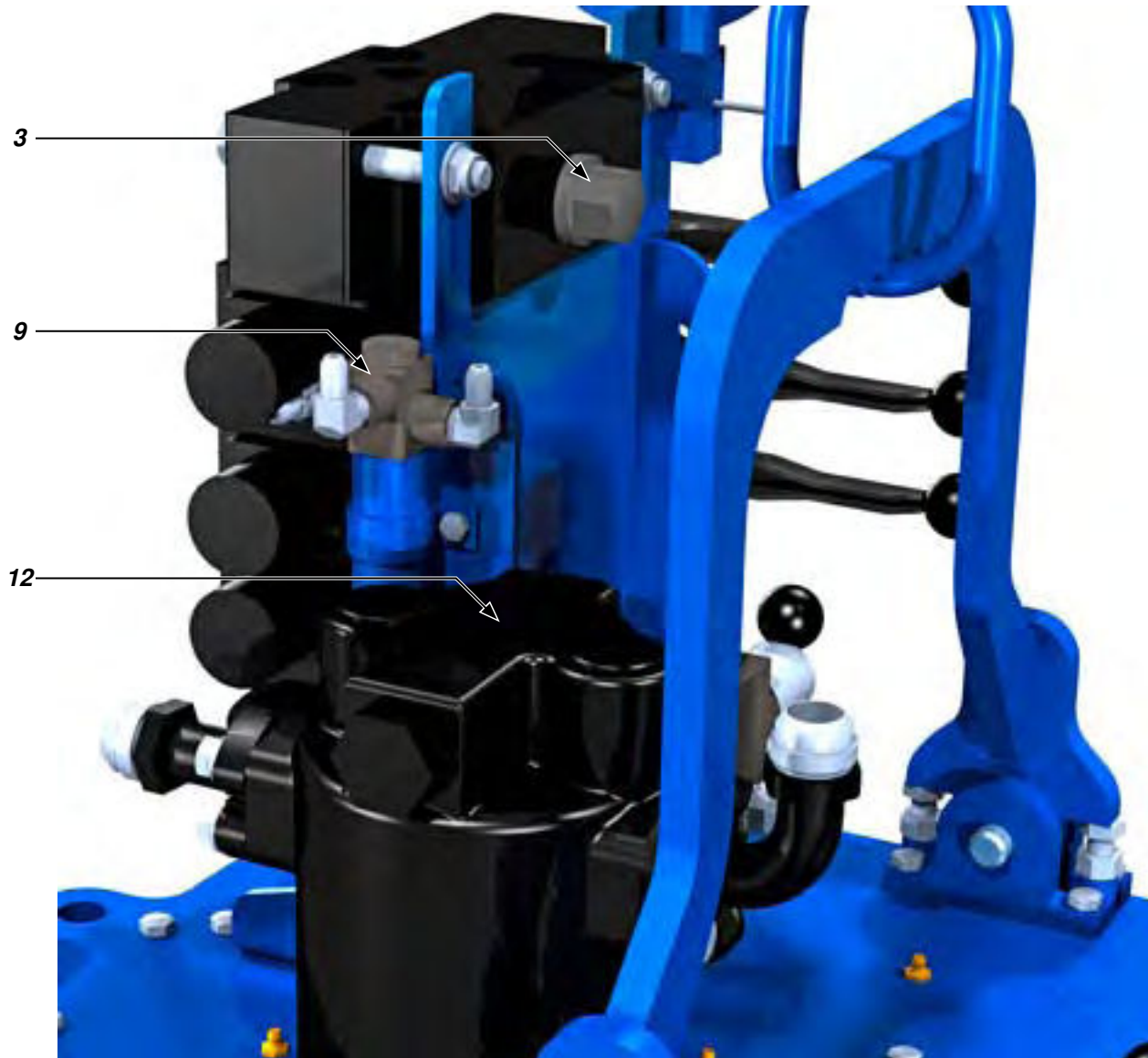

ILLUSTRATION 2.C.4: HYDRAULIC COMPONENT IDENTIFICATION 03

D. HYDRAULIC CONNECTIONS

A pair of hydraulic lines - a 1" supply line and a 1-1/4" return line - connect the tong to the power unit (see illustration below). Ancillary devices (hydraulic motors, hydraulic cylinders, etc.) are connected through the valve block.

Perform any hydraulic connection when the power unit is not running, or when the hydraulic pump is disengaged. The possibility of error in inter-changing the high pressure supply hose and the low pressure return hose has been eliminated, because the supply side coupling is smaller than the return side.



THE INLET & OUTLET HYDRAULIC HOSES ANTI-WHIPLASH LANYARDS MUST BE ATTACHED TO THE TONG WITH ANTI-WHIPLASH LANYARDS

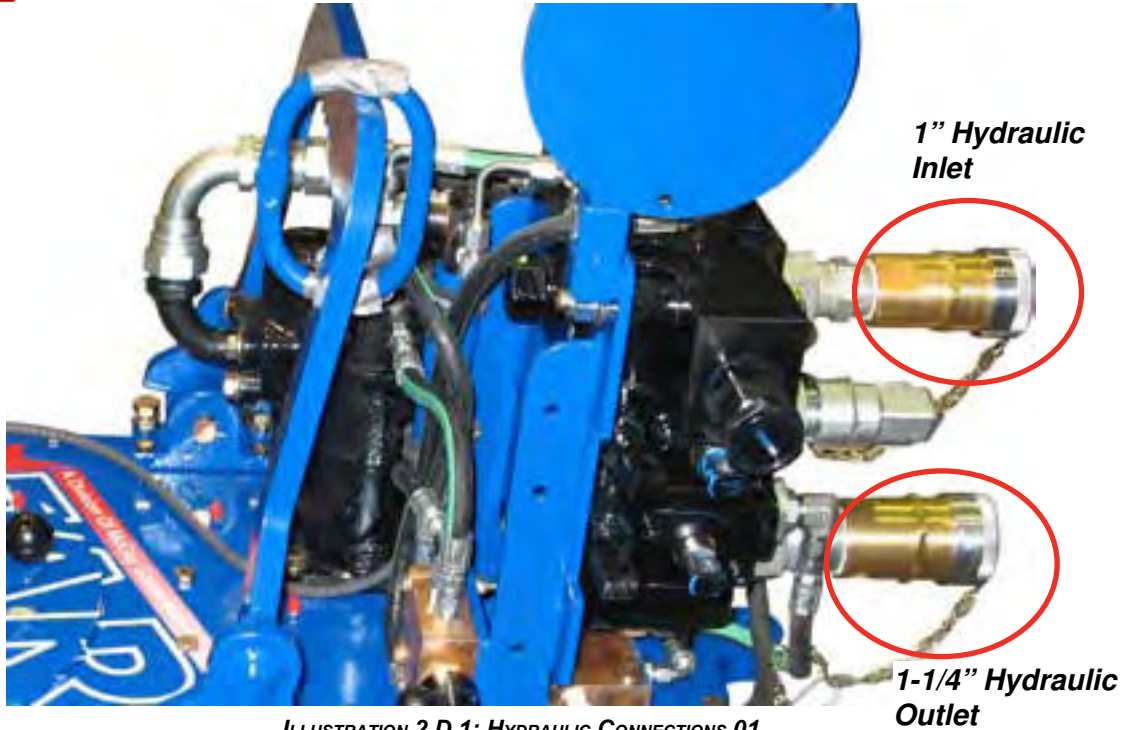
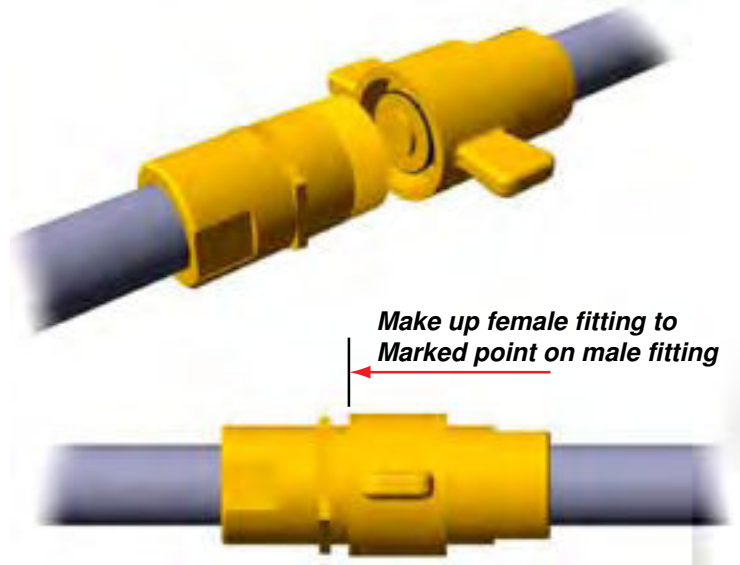

ILLUSTRATION 2.D.1: HYDRAULIC CONNECTIONS 01

These hose couplings are self-sealing, and care should be taken to ensure complete engagement to prevent partial closure of the check valve in the coupling. Ensure that the nut (female) side is completely made up onto the male connector - there is a line on the male fitting that indicates complete make-up. Snug the female fitting right up to the line.



**Make up female fitting to
Marked point on male fitting**

ILLUSTRATION 2.D.2: HYDRAULIC CONNECTIONS 02

E. TONG JAW AVAILABILITY & INSTALLATION

1. Jaw Availability

The following table lists all jaw die kits that are available as standard stocked sizes for this model of tong. McCoy Drilling & Completions | Farr offers a good selection of standard jaw sizes. However, please note that we can custom-engineer and manufacture any size of jaw within the range of the tong. Jaw systems are available to allow use of die inserts intended for specialized applications. Call our sales office for information on jaw and die systems designed for higher or lower grip, or non-marking applications.

The table lists standard contoured, flat and wraparound die inserts that are available as spare parts. However, a wide variety of diamond-tooth, GRITFACE®, aluminium, and wrap-around fine-tooth dies are available for specialized applications. Please refer to our website for complete information:

<http://www.mccoysglobal.com/index.php/dies-inserts>

Description	Part Number	Description	Part Number
1.9" Jaw Die Kit	SL4500-JDK-1900	1.9" Wrap Around Jaw Die Kit	SL4500-WJDK-1900
2.063" Jaw Die Kit	SL4500-JDK-2063	2-3/8" Wrap Around Jaw Die Kit	SL4500-WJDK-2375
2-3/8" Jaw Die Kit	SL4500-JDK-2375	2-7/8" Wrap Around Jaw Die Kit	SL4500-WJDK-2875
2-7/8" Jaw Die Kit	SL4500-JDK-2875	3" Wrap Around Jaw Die Kit	SL4500-WJDK-3000
3" Jaw Die Kit	SL4500-JDK-3000	3.1875" Wrap Around Jaw Die Kit	SL4500-WJDK-3187
3.068" Jaw Die Kit	SL4500-JDK-3068	3-1/2" Wrap Around Jaw Die Kit	SL4500-WJDK-3500
3-1/2" Jaw Die Kit	SL4500-JDK-3500	3-5/8" Wrap Around Jaw Die Kit	SL4500-WJDK-3625
3-5/8" Jaw Die Kit	SL4500-JDK-3625	4" Wrap Around Jaw Die Kit	SL4500-WJDK-4000
3.668" Jaw Die Kit	SL4500-JDK-3668	4-1/2" Wrap Around Jaw Die Kit	SL4500-WJDK-4500
4" Jaw Die Kit	SL4500-JDK-4000	5" Wrap Around Jaw Die Kit	SL4500-WJDK-5000
4-1/2" Jaw Die Kit	SL4500-JDK-4500		

All jaw die kits except "Wraparound" use flat die P/N 12-1003MOD

Contact Farr Sales for "Wraparound" dies.

If necessary the entire jaw may be removed. Support the jaw from the bottom and remove the jaw retainer bolt. The jaw may then be slid out of and away from the cage plate. Reverse this procedure to replace the jaw assemblies

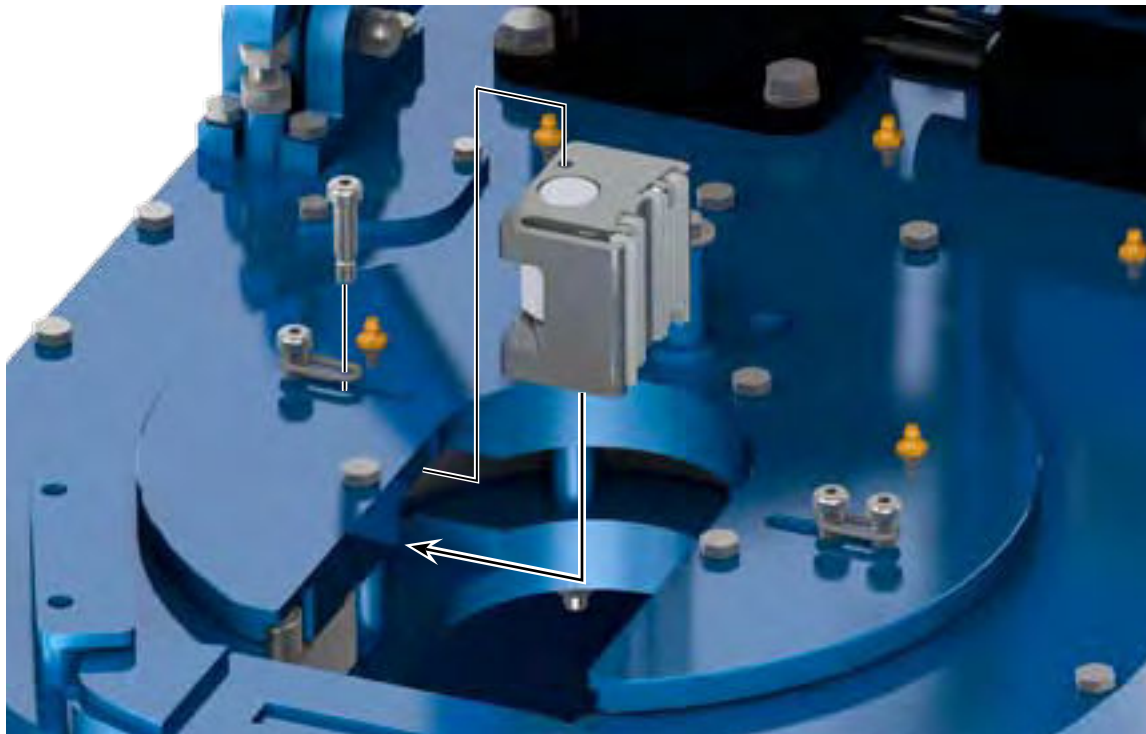

ILLUSTRATION 2.E.1: TONG JAW REMOVAL

To release dies from a jaw assembly, remove the retaining bolts and slide dies out. Repeat this procedure in reverse to install new dies.

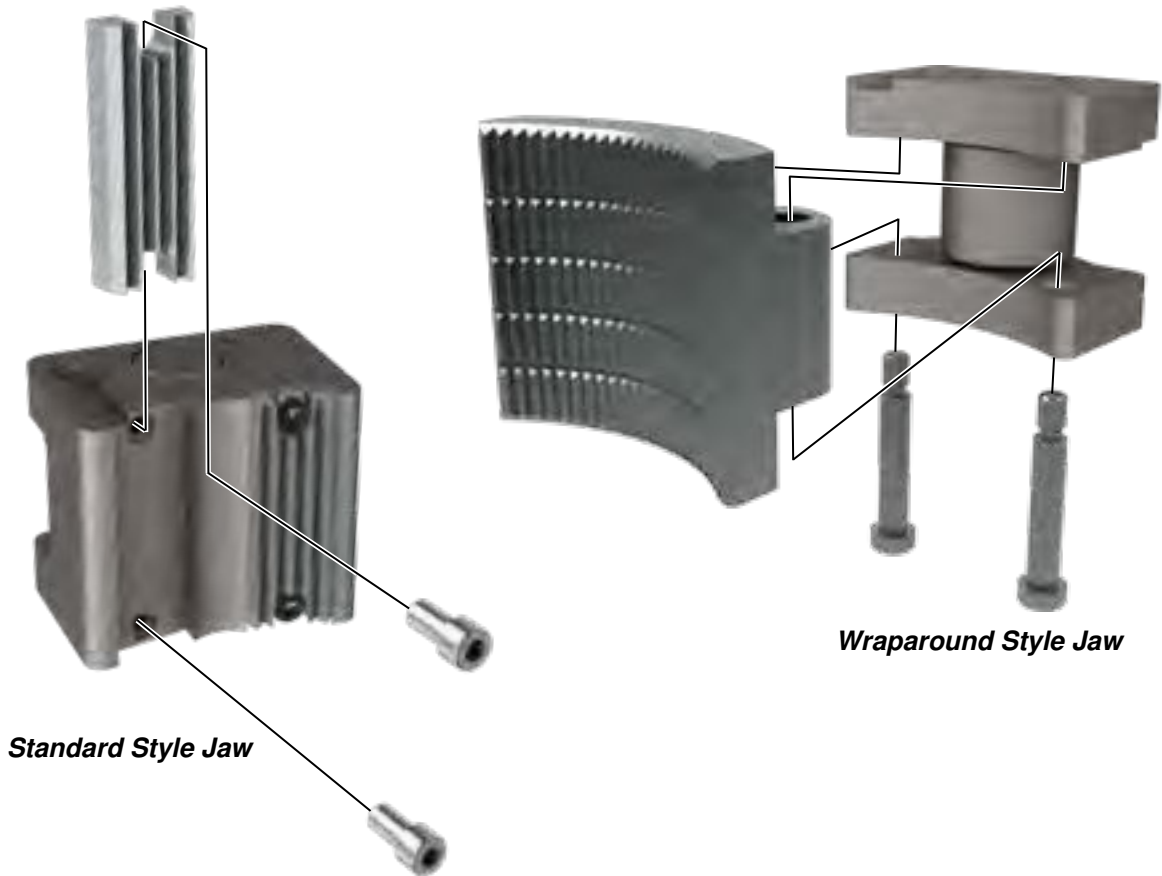

ILLUSTRATION 2.E.2: TONG JAW DIE REPLACEMENT

2. Backup Jaws

The jaw die kits used in the Farr backup are identical to those used in the "slim" tong (see previous page). Follow the same removal and installation instructions as for the tong jaw die kits.

3. Tong Handles

Tong handles may be supplied as an accessory with this tong. They may be removed for operational needs and requirements.

F. TONG RIG-UP & LEVELING

1. Suspension & Restraint

Suspend the tong and backup from a location as near to the centre of the drill rotary as possible, and from a location high enough on the mast to ensure easy handling. The lower the point from which the tong is suspended, the more effort will be required to move the tong to and from the connection point.

The suspension line may be extended over a pulley and balanced by a counterweight equal to the weight of the tong and backup, or simply tied off in the derrick to form a dead line. When using a dead line arrangement it is necessary to use a FARR spring hanger assembly (see specification page for recommended spring hanger). This spring hanger compensates for the downward movement of the casing as the thread is made-up, and imparts additional force to the suspension cable:

- a "single spring" hanger typically applies 420 lbs. (191 kg.) to the suspension line for every inch of thread made up
- a "double spring" hanger typically applies 840 lbs. (382 kg.) to the suspension line for every inch of thread made up

If you do not know which specific spring hanger is in use, check the specification page in this manual for information on the recommended spring hanger for this application. McCoy Drilling & Completions will not guarantee or specify spring hangers other than what has been supplied by McCoy.

Many applications use a lift cylinder for adjusting the height of the tong. Ensure the weight of the lift cylinder is known if it has not been included in the total weight of the tong.

Suspension & Restraint (continued):

All forces upon the suspension line must be considered when calculating necessary strength of the suspension line. The weight of the tong, the weight of the lift cylinder, the weight of the spring hanger, and the force imparted on the suspension line by the spring hanger must all be added together in order to arrive at the total force supported by the suspension line. Select your suspension line based upon the total force and the margins of safety dictated by the policies of your company and by established engineering practices. Ultimately, calculating the force on the suspension line and selection of the suspension line is the complete responsibility of the customer.

McCoy Drilling & Completions recommends using dual backup (snub) lines of sufficient strength to withstand the force imparted by the maximum rated torque of the tong and backup assembly in use. The snub lines will arrest uncontrolled movement of the tong and backup in the event slipping of the backup jaws. Calculate the force on the snub lines by dividing the maximum torque of the tong by the tong's torque arm (expressed in feet). For example, an 8,000 lbs.-ft. tong with an 18 inch (1.5 ft.) torque arm will generate 5333 lbs. of force against the snub line. Select your snub lines based upon the total force and the margins of safety dictated by the policies of your company and by established engineering practices. Ultimately, calculating the force on the snub line and selection of the snub line is the complete responsibility of the customer.

Snub lines must be securely connected to the rear of the tong and backup assembly, and tied off to a suitable anchor.



FARR CANADA CORP. ACCEPTS NO RESPONSIBILITY FOR DESIGNING AND SELECTING AN ADEQUATE SUSPENSION AND RESTRAINT SYSTEM FOR YOUR DRILLING EQUIPMENT



ALL SELECTED FASTENERS, SHACKLES, CLAMPS, ETC. USED FOR CONSTRUCTING THE SUSPENSION AND SNUB LINES MUST BE RATED FOR THE CALCULATED FORCES.

2. Tong Leveling

The tong must be leveled side-to-side and front-to-rear before placing into service. The following guidelines will assist you when leveling your tong.

- i. Lift the tong by the main lifting link. Place a level axially (side to side) across the tong, ensuring that it is parallel with the surface of the tong. If the tong is not hanging level, move the main link to an adjacent notch on the hanger to move the tong closer to the level position.



THE MASTER LINK MUST BE USED TO SUSPEND THE TONG ASSEMBLY



ILLUSTRATION 2.F.1: MASTER LINK

- ii. Place a level lengthwise (front to back) along the tong, ensuring that it is parallel with the surface of the tong. Loosen the 1/2" locking nuts on the adjusting bolts on rigid sling brackets. Completely loosen the adjusting bolts. Turn each adjusting bolt equally until tong hangs level front-to-back. Lock adjusting bolts in place with the lock nuts.

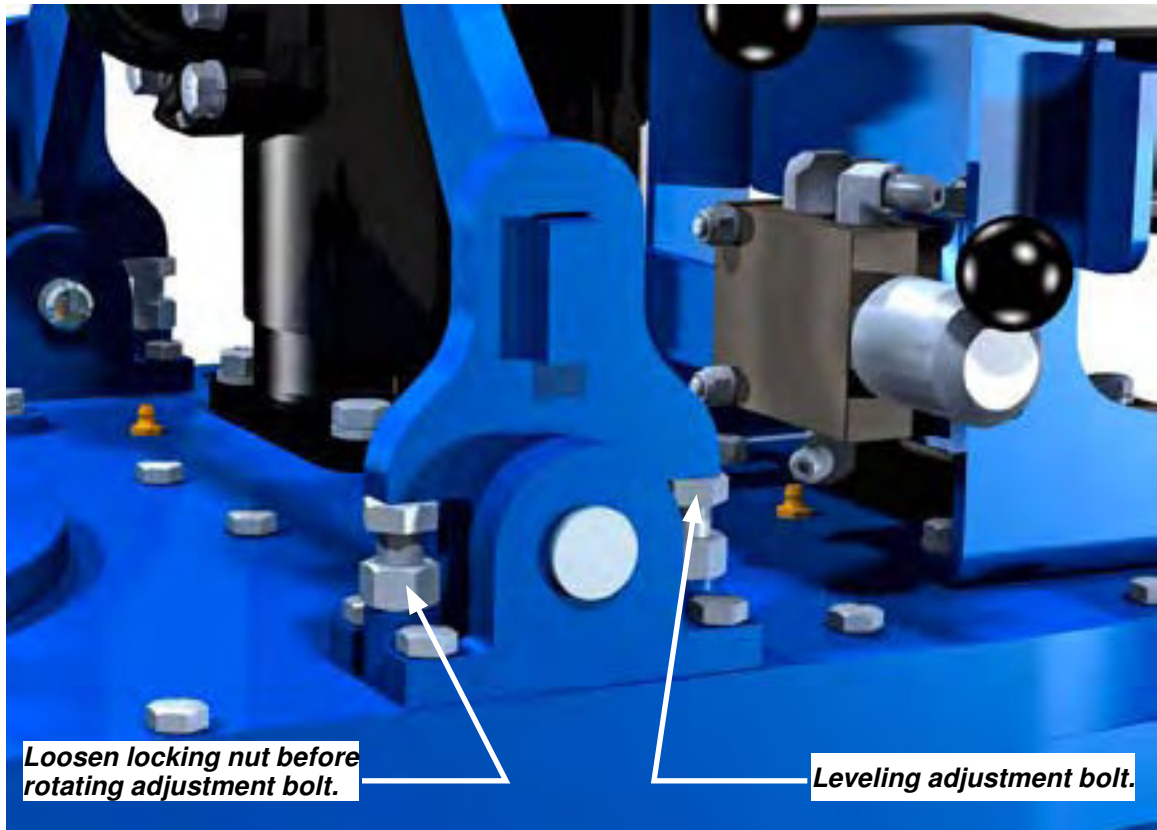

ILLUSTRATION 2.F.2: TONG LEVELING

3. Load Cell Configuration

The backup is directly coupled to the compression load cell via the backup body paddle. The load cell hanger is simply hung in its slot on the paddle, and in normal operation does not need to be adjusted or removed. The assembly in the first of the following two illustrations has been configured in the "make-up" configuration; to convert the assembly to the "break-out" configuration simply lift the load cell holder / spacer assembly off the paddle, rotate it 180°, and replace - no tools are required for this operation.



**Load Cell - Makeup
Configuration**

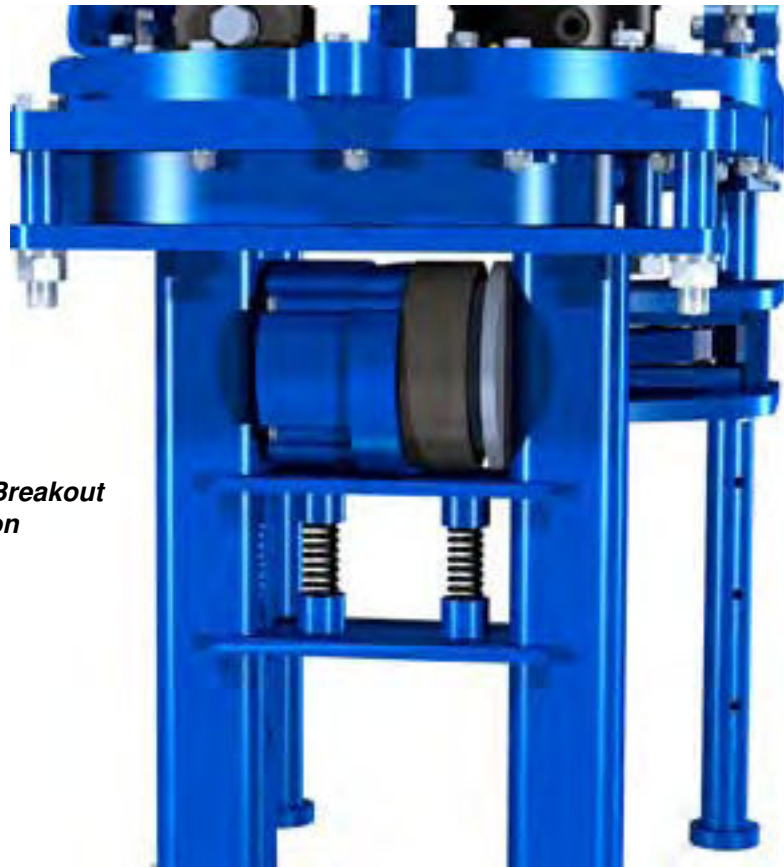

**Load Cell - Breakout
Configuration**

ILLUSTRATION 2.F.3: LOAD CELL CONFIGURATION

G. TONG OPERATION

1. Operator Training

Many companies set qualification standards that must be met before equipment is may be operated without supervision. McCoy Drilling & Completions recommends operator training, which typically consists of operation of the equipment under the supervision of a trained equipment operator until a satisfactory level of competence is achieved. Typical operator training should include:

- Introduction to and general description of equipment
- Technical specifications and performance data
- Operating instructions
- Control systems and interlocks
- Operating hazards
- Checks and inspections

2. Initial Start-up and Break-in Procedure



YOUR EQUIPMENT HAS BEEN THOROUGHLY TESTED AND INSPECTED AT THE FACTORY. HOWEVER, WE ADVISE INSPECTION AND TESTING OF YOUR NEW TONG AFTER TAKING POSSESSION IN ORDER TO ELIMINATE THE POSSIBILITY OF SHIPPING DAMAGE.

McCoy Drilling & Completions recommends that the following pre-operating tests be performed after receipt from the factory or after extended storage, prior to releasing the tong to operations:

- Perform a complete inspection of all fasteners to ensure none have loosened during transport.
- Connect the tong to the power unit, and apply full hydraulic pressure. Inspect and correct any leaks.
- Operate the tong at full speed and in high gear for a duration of one-half hour. Hot bearing caps may indicate impending bearing failure.
- Switch to low gear and operate for an additional one-half hour at full speed.
- Run the backup through several clamp/un-clamp sequences to ensure functionality.
- Inspect all components and hydraulic fittings for possible defects following completion of the tests. All FARR Tongs have been thoroughly tested at the factory prior to shipping, but shipping damage must be identified before running the tong in an operational environment.
- Carefully inspect the safety door components, and test to ensure that the safety device on each door is operating correctly before releasing the tong to the operating environment.



TONG DOOR MUST BE CLOSED AND SECURELY LATCHED BEFORE THE POWER UNIT IS STARTED IN ORDER TO ASSURE THE SAFETY OF OPERATING PERSONNEL

Ensure adequate lube oil and hydraulic oil levels before starting engine. Use start up procedures as recommended by the power unit engine operator's manual. Open the Bypass Valve on the hydraulic system, and inspect all pressure and return line hose connections to ensure correct and secure installation.

IMPROPERLY SECURED HYDRAULIC CONNECTIONS WILL INTERRUPT HYDRAULIC FLUID FLOW, AND COULD RESULT IN THE FOLLOWING FAILURES:



- A restriction in the pressure supply hose will result in high pressure within the power unit hydraulic system, which will activate the hydraulic governor and increase the engine speed to as high as maximum RPM.
- A restriction in the return line will result in high pressure within the power unit and the tong hydraulic system, causing engine speeds as high as maximum RPM, and possible failure of the motor seal.

Following inspection of the hoses, start the engine and allow it to idle until warm. Allow hydraulic fluid to circulate for approximately 10 minutes, then slowly close the Bypass Valve to allow hydraulic fluid to circulate through the hoses and to the tong (circulating pressure should not exceed 200 psi). Place the tong gear shifter in low gear and rotate the tong slowly forward and then reverse with the throttle valve control lever. Once this has been done and the proper size jaws have been installed, the tong is then ready to run pipe.

3. Valve Operation

Proportional valves control operation of hydraulic devices on the tong assembly, such as hydraulic motors and cylinders. When any one valve is "centered" or in the detent position, there is no hydraulic output from the valve. When the valve is pushed forward there is an effect, and when the valve is pulled back, there is an opposite effect. These valves feature proportional control, which means that further extension of the valve handle (thereby further opening the valve orifice) results in proportionally higher hydraulic output to the controlled device. The following illustration demonstrates the type and effect of the hydraulic valves with which this tong is may be equipped.

TONG MOTOR

This is a proportional valve. Pushing the valve handle forward will cause the tong motor to rotate in a clockwise direction (as seen from the top of the tong). This is the desired direction of rotation for making up a joint. Pulling the valve handle in the opposite direction results in counter-clockwise rotation, which is the desired direction of rotation for breaking out a joint.

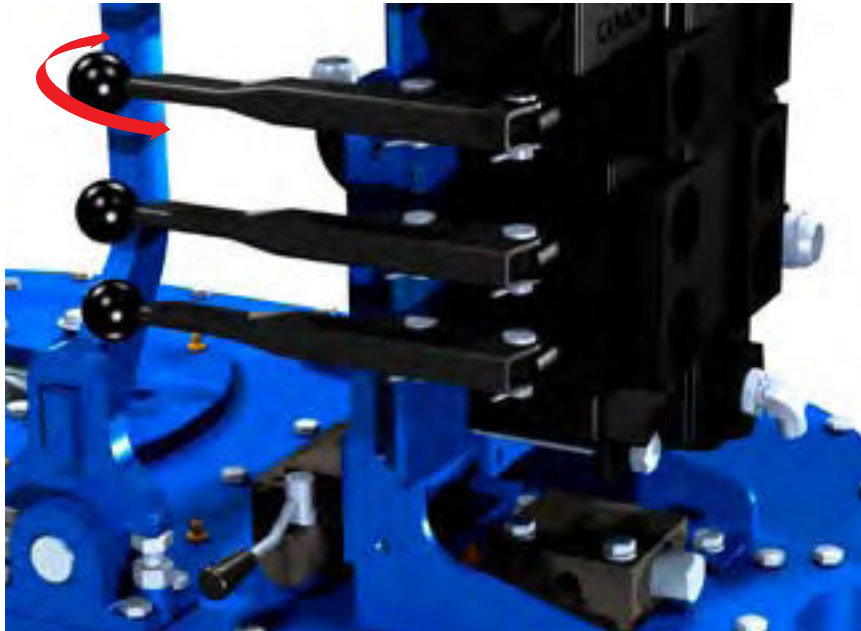

ILLUSTRATION 2.G.1: TONG MOTOR CONTROL

LIFT CYLINDER

This is a direct-acting valve. Pushing the valve handle forward will cause the lift cylinder to lift the tong vertically. Pulling the valve handle in the opposite direction will cause the lift cylinder to lower the tong.

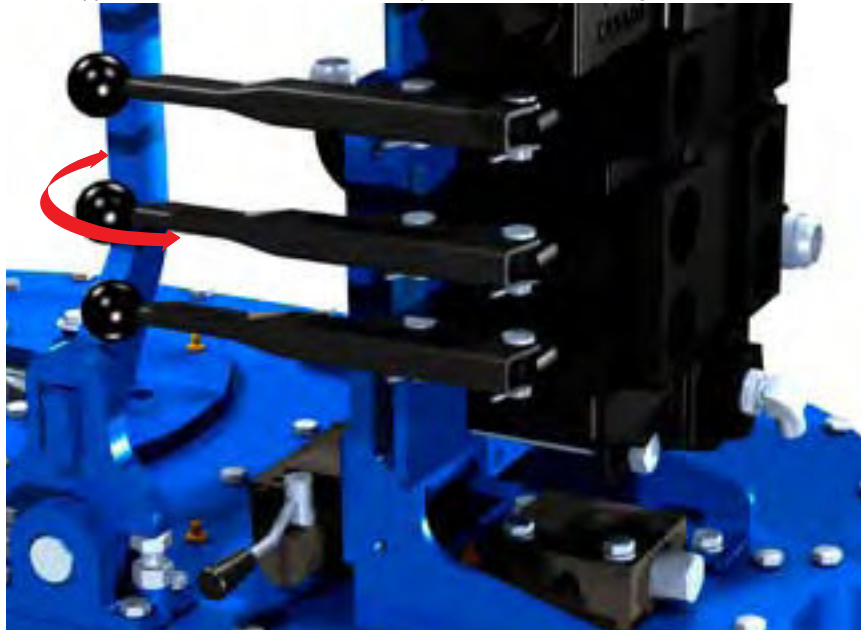

ILLUSTRATION 2.G.2: LIFT CYLINDER CONTROL

BACKUP

This is a two-way direct acting valve, without proportional control. Pushing the valve handle forward will cause the backup to engage. Pulling backward, towards the operator, reverses the operation.

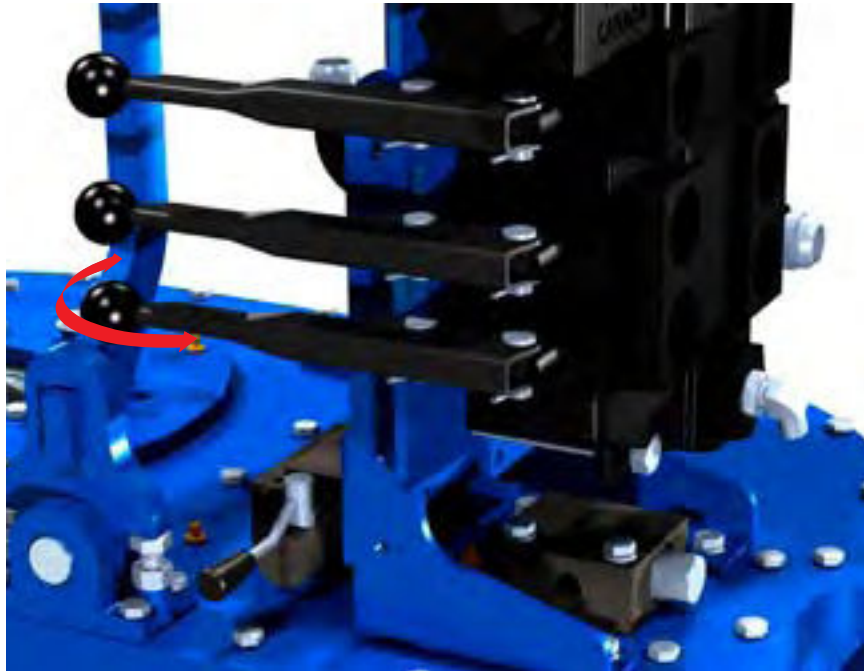

ILLUSTRATION 2.G.3: BACKUP CLAMP CONTROL

TONG SPEED

The motor speed valve offers safe and smooth adjustment of the tong speed without the need to manipulate gears in a gear train. Simply rotate the speed valve to change the speed of the motor. The simplicity of this system is particularly useful when making up or breaking out a joint.

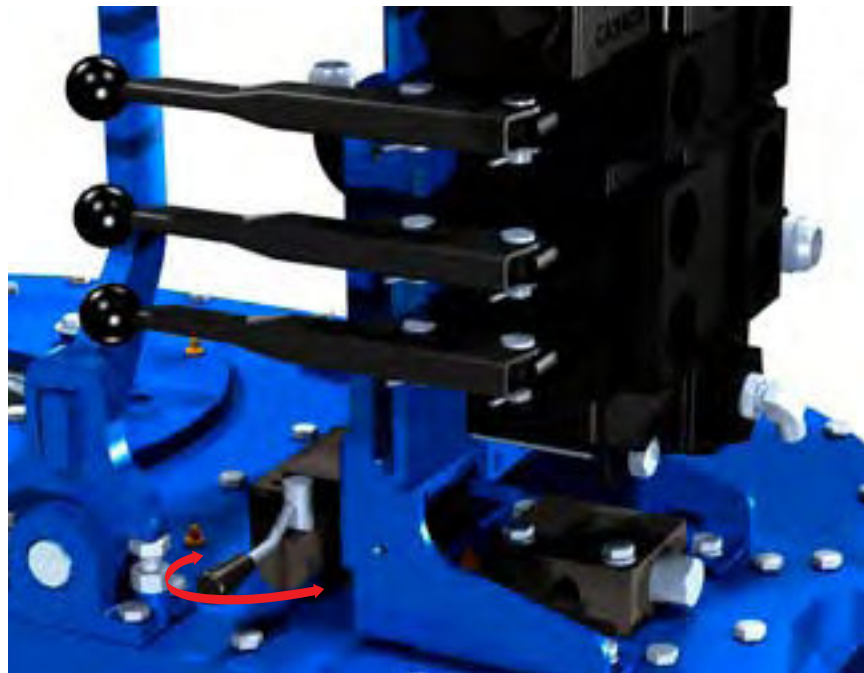

ILLUSTRATION 2.G.4: MOTOR SPEED CONTROL

4. GENERAL COMMENTS

- a) Position rotary gear in contact with both idler gears when breaking out joints or collars where high torques are required.
- b) When making-up integral (shouldered) joints, it is essential to make up the last turn of the threads in low gear. This reduces the tendency of an instant stop or a sudden increase in torque, which induces extremely high stresses on the gear train.
- c) DO NOT employ the "snap break" method of breaking-out joints when pulling a string. By definition, the "snap break" method is a procedure used by some operators to break out connections, accomplished by leaving slack in the "jaw-pipe" engagement, and then quickly pulling the throttle valve control lever allowing the tong to snap into its loaded or high torque condition. Although this method is very effective in breaking out joints, the extremely high stress placed on the gear train frequently causes gear breakage.

**THE "SNAP-BREAK" METHOD IS HAZARDOUS TO RIG PERSONNEL****H. EXTREME COLD WEATHER OPERATION PROCEDURES**

- 1) Consult the power unit engine operator's manual for all cold weather operating procedures and precautions.
- 2) Select gear and bearing lubricants that are compatible with expected climatic conditions.
- 3) Select hydraulic fluid that is compatible with expected climatic conditions.
- 4) Allow hydraulic fluid to circulate for approximately 20 minutes after starting the power unit, prior to activating the bypass valve to allow fluid to circulate to tong. If the power unit is equipped with an oil temperature gauge, ensure that the fluid has reached operating temperature as specified by hydraulic fluid data sheet.
- 5) Allow for adequate drying of moisture (prior to lubricating) when cleaning tong parts in cold weather.

I. MAKING AND BREAKING CONNECTIONS

Set up and prepare your equipment for operation as per Section 2 of the SL-4500 Technical Manual. Refer to the following sections:

- 2.D - Hydraulic Connections
- 2.E - Tong & Backup Jaw Installation
- 2.F.1 - Tong Rig-up and Leveling, Suspension
- 2.F.2 - Tong Rig-up and Leveling, Leveling
- 2.F.3 - Tong Rig-up and Leveling, Load Cell Configuration

Your tong and backup assembly should be properly suspended, connected to a hydraulic power source, and ready to make or break connections at this point.



THIS PROCEDURE ASSUMES THE USER HAS PROPERLY SET UP AND PREPARED THE EQUIPMENT FOR OPERATION AS PER SECTION 2 OF THE TECHNICAL MANUAL

1. Making Up A Connection

- a) Ensure hydraulic power supply to the tong and backup is energized. The master link on the rigid sling must be used to suspend the tong. Do not suspend the tong directly from the rigid sling.



ILLUSTRATION 2.I.1: TONG SUSPENSION - MASTER LINK



THE MASTER LINK MUST BE USED TO SUSPEND THE TONG ASSEMBLY

- b) Ensure the backing pin is in the "makeup" position. From the front of the tong, the backing pin correctly configured for makeup will be in the 10 o'clock position. If it is not, simply lift up and place in the correct position (see Illustration 2.I.2 next page). The cage plate opening must be aligned with the door opening when setting the backing pin position.

Making A Connection (continued):**ILLUSTRATION 2.1.2: SETTING BACKING PIN TO "MAKE-UP"**

- c) Ensure the load cell is properly configured for making up connections. See Section 2.F.3 of the SL-4500 Technical Manual for correctly configuring your equipment.
- d) McCoy Drilling & Completions recommends that backup pressure be pre-set for the size of tubing before starting the job (no tubing is required for this procedure):
 - Backup clamping pressure is only displayed when the backup jaws are closed in the "clamp" position. Close the backup jaws using the backup control handle.

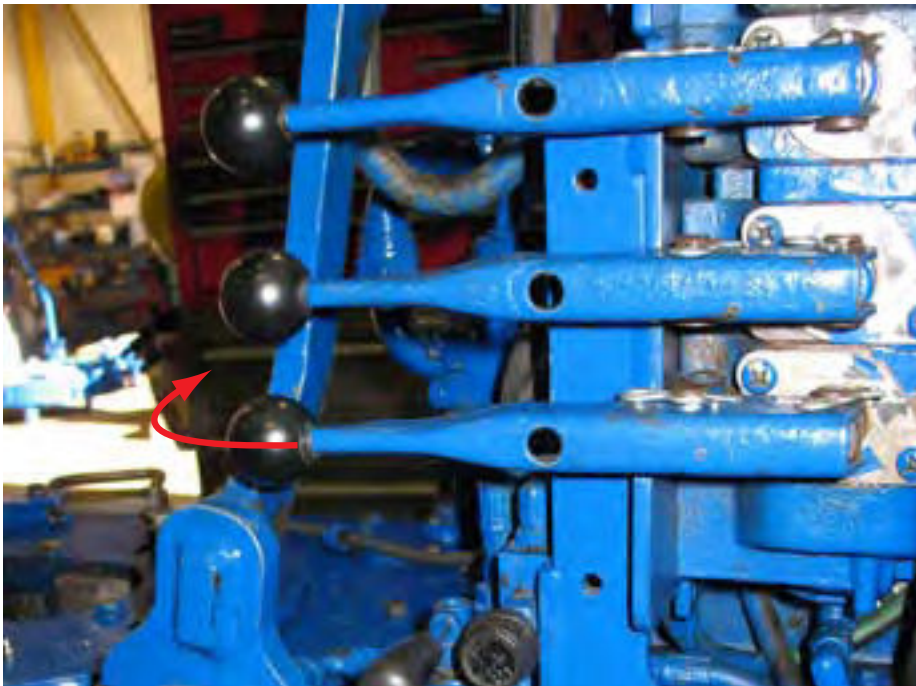
**ILLUSTRATION 2.1.3: BACKUP CONTROL**

Making A Connection (continued):

- d) *Setting backup pressure (continued)*
 - Observe the backup pressure as indicated on the "CLAMP" pressure gauge



ILLUSTRATION 2.1.4: CLAMP PRESSURE GAUGE ON GAUGE PANEL

- Hydraulic pressure on the clamp cylinders must be relieved before the clamping pressure can be adjusted. Relieve pressure by pulling back on the backup control handle enough to actuate the relief, but not enough to retract the cylinder.
- Use the backup pressure control knob to adjust the pressure. Turning the knob clockwise increases clamping pressure, and turning the control knob counter-clockwise decreases clamping pressure.

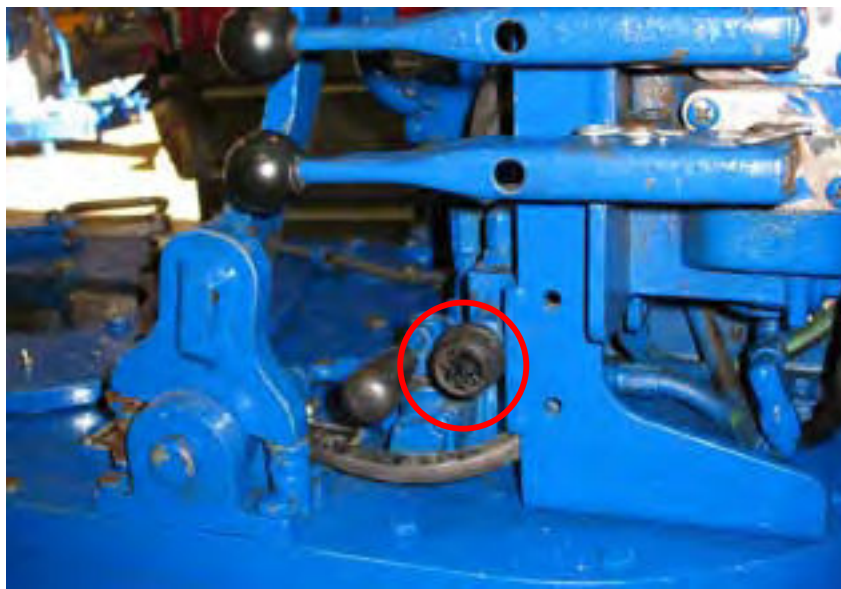

ILLUSTRATION 2.1.5: BACKUP PRESSURE CONTROL VALVE

Turn the knob in small increments i.e. 1/4 turn at a time, and check clamping pressure after every pressure adjustment. Ensure the pressure on the clamp cylinders is relieved before re-adjusting pressure.

Making A Connection (continued):

- d) *Setting backup pressure (continued)*
- *If pressure data from previous jobs is unavailable, McCoy recommends setting the initial backup pressure to 1900 PSI and increase the pressure incrementally if required. If pressure data is available, set the final backup pressure to the pressure required for the job. Due to a wide variety of tubing wall thicknesses it is impossible to recommend optimum backup pressure settings from the factory for each size of tubing.*
 - *Retract clamp cylinders once backup pressure has been satisfactorily set.*
- e) *Open the tong door. If your equipment is equipped with a safety door, opening the door will inhibit rotation of the cage plate.*

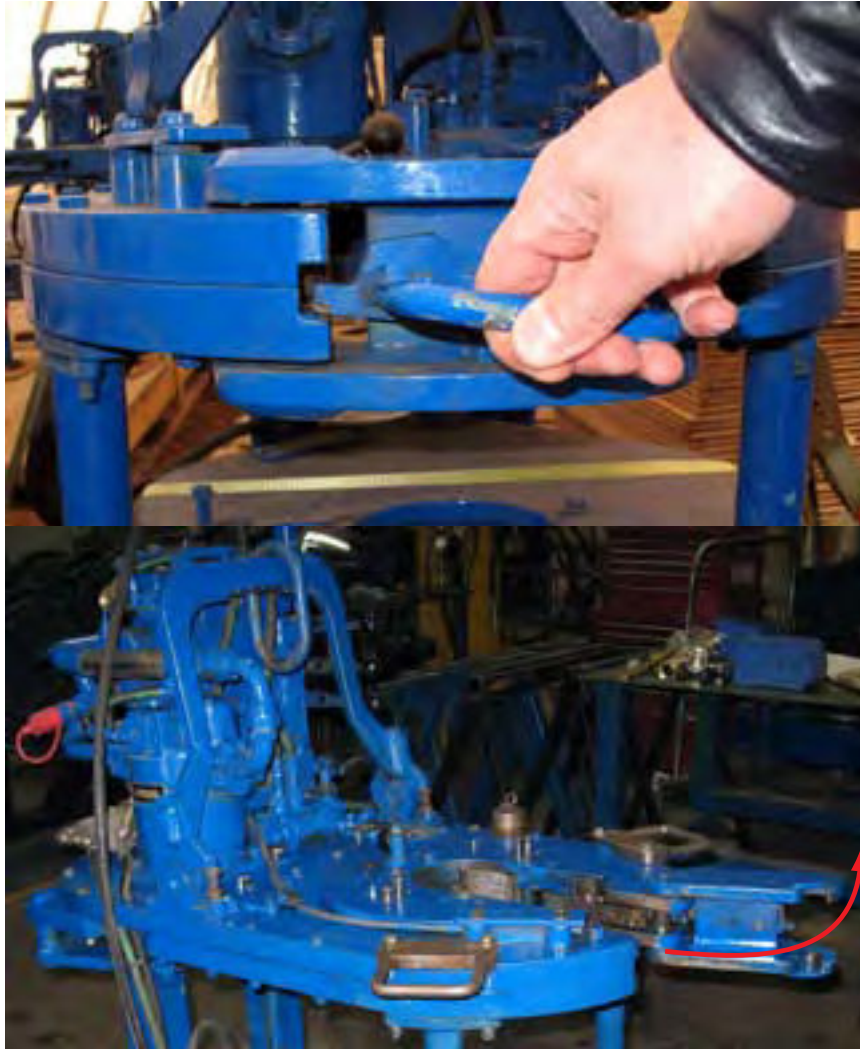

ILLUSTRATION 2.1.6: UNLATCHING & OPENING DOOR

- f) *Manually engage the threads of the tubing connection being made up. Ensure threads are not cross-threaded.*

Making A Connection (continued):

- g) Actuate the lift cylinder control valve to lift the assembly from the drill floor. Pushing the valve toward the center of the tong will retract the lift cylinder to lift the assembly (see illustration 2.1.7 below). Note that rig personnel are required to stabilize the tong and backup as it is being lifted so it does not swing and collide with other rig equipment.



RIG PERSONNEL MUST STABILIZE THE TONG AND BACKUP AS IT IS LIFTED FROM THE DRILL FLOOR

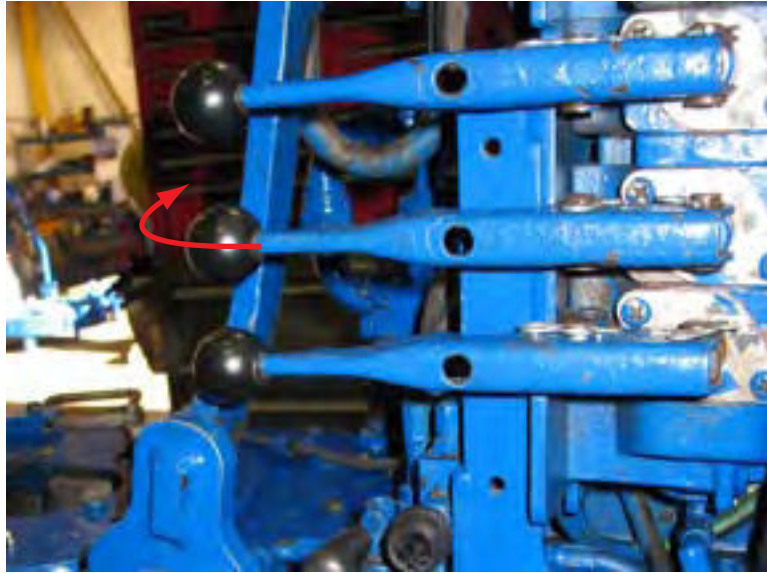
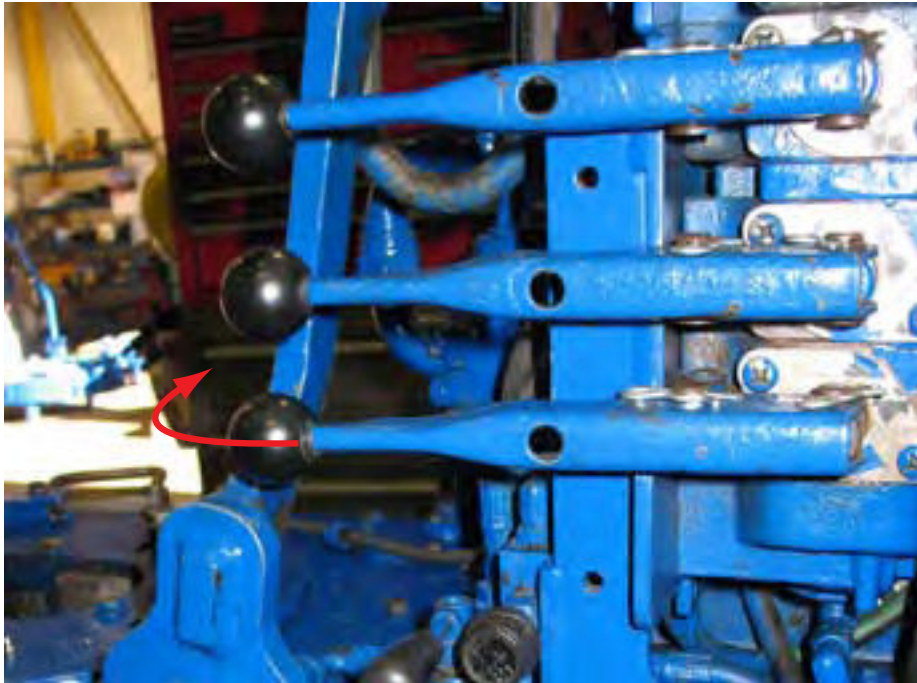
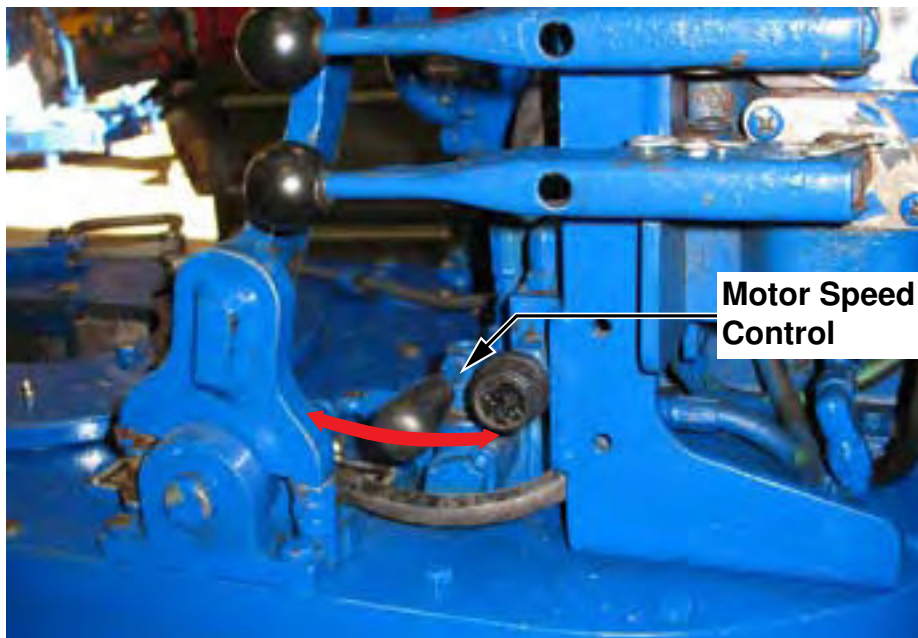

ILLUSTRATION 2.1.7: LIFT CYLINDER CONTROL

- h) Move the tong and backup assembly on to the tubing joint. Use the lift cylinder to ensure the assembly is at the correct height so that the backup jaws are located below the connection point, and the tong jaws are located above the connection joint.
- i) Close the tong door. Ensure the door is securely latched (tug on the door handle to ensure it remains latched).
- j) The "snub line" is a length of wire rope that connects the pad eye on the centre rear of the tong body to a sturdy post on the drill floor. The snub line prevents the tong body from spinning in the opposite direction of the cage plate when torque begins to build in the joint. The wire rope and shackles or connectors that make up the snub line must be appropriately rated for the applied torque - see Section 2.F.1. The snub line connection point on the drill floor must be sturdy enough to absorb all applied torque when making up the joints. When making up joints the snub line is attached to the driller's side of the tong, which is the left side of the tong as seen from the rear.
- k) Ensure tubing is roughly centered within the tong and backup jaws - rig personnel are required to stabilize the tong and backup around the connection until the jaws have been clamped shut. Actuate the backup clamping valve (push it toward the centre of the tong) to clamp the backup jaws on to the tubing below the connection point. Note that the backup control is "clamp and release", meaning that once the backup jaws are clamped, the jaws remain under clamping pressure until the operator manipulates the backup control handle to release pressure (see Illustration 2.1.8).

Making A Connection (continued):**ILLUSTRATION 2.1.8: BACKUP CONTROL**

- l) The motor speed control valve may be in one of three positions:
- UP - High speed selected
 - MIDDLE - Neutral position
 - DOWN - Low speed selected

**ILLUSTRATION 2.1.9: MOTOR SPEED CONTROL**

If not already in the "high speed" position grasp the motor speed control valve and firmly lift up until it "latches" into its detent position. Gently push the rotation control valve toward the centre of the tong to slowly rotate the cage plate until the tong jaws grip the tubing (see Illustration 2.1.10 next page).

Making A Connection (continued):

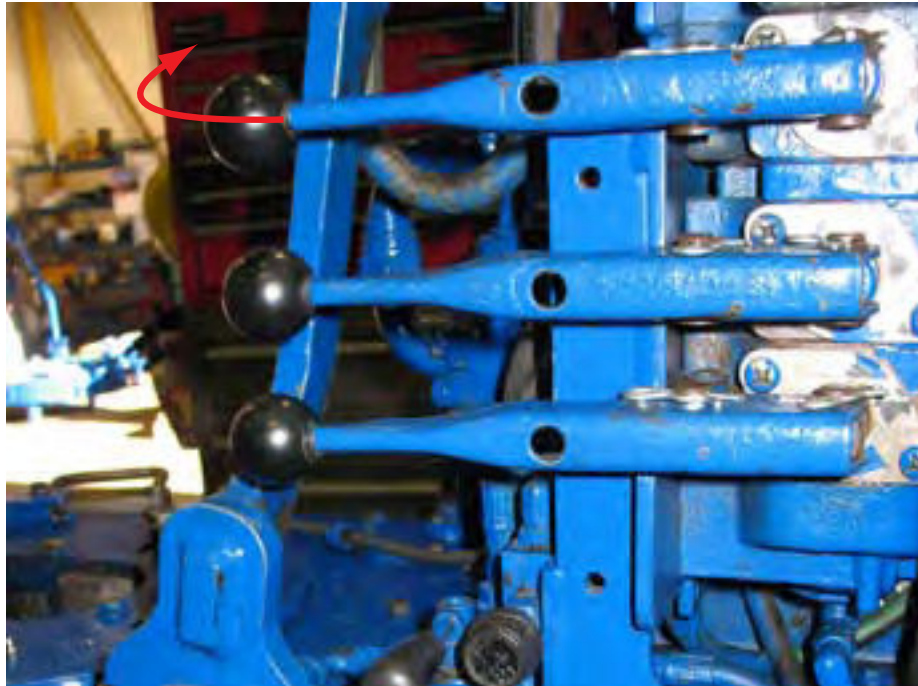

ILLUSTRATION 2.I.10: ROTATION CONTROL - MAKEUP

- m) When the tong jaws grip the tubing push the rotation control handle all the way in to thread the connection together at high speed. As the joint becomes fully made up the increasing torque demand will stall the motor, and system pressure and displayed torque will increase.



ILLUSTRATION 2.I.11: TORQUE & SYSTEM PRESSURE GAUGES ON GAUGE PANEL

Making A Connection (continued):

- n) When system pressure and torque begin to rise, switch to low speed:
- Do not release the rotation control
 - Grasp the speed control knob and firmly push it down to the low speed setting. Motor speed decreases by 50 percent, and available torque doubles.



ILLUSTRATION 2.I.12: SWITCHING MOTOR SPEED SWITCH TO LOW SPEED

- o) Observe the tubing in the backup as the joint approaches the specified make-up torque. If the tubing begins to slip in the backup, increase the backup pressure in 50 psi increments until the tubing stops slipping. Makeup torque must be reached without any tubing rotation in the backup. When that has been achieved record the backup pressure for future reference. As you gain experience with your equipment make up a "pressure vs. tubing size" chart that can be referred to when making future connections, ensuring proper backup pressure settings without risking crushed tubing.
- p) When proper makeup torque has been reached reverse the rotation control valve to release the tong jaws from the tubing.

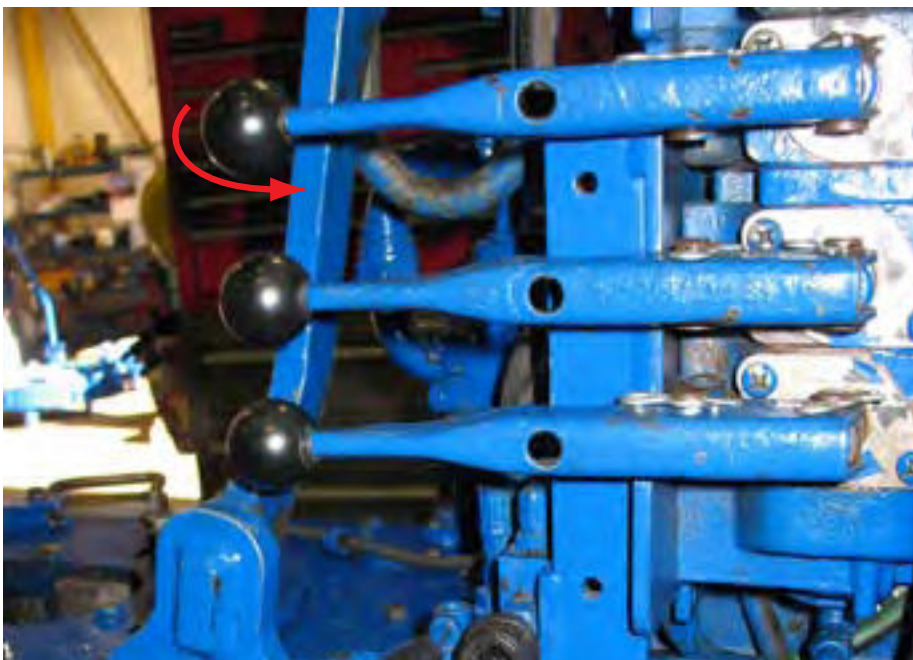

ILLUSTRATION 2.I.13: REVERSING ROTATION TO FREE TONG JAWS

Making A Connection (continued):

- q) When tong jaws are free release the backup jaws by pulling the backup clamp control handle away from the tong toward the operator.



ILLUSTRATION 2.1.14: UN-CLAMPING BACKUP JAWS

- r) Unlatch and open the tong door to free the assembly from the tubing. Note that rig personnel may be required to stabilize the equipment as it completely releases from the tubing. Guide the assembly away from the string and use the lift cylinder control to lower it to the drill floor.

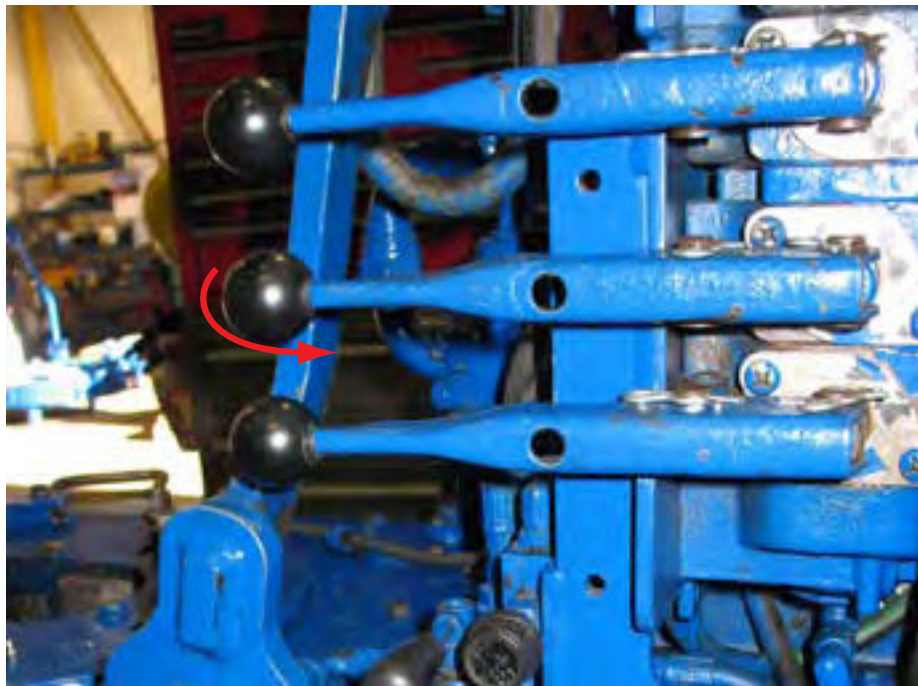

ILLUSTRATION 2.1.15: LOWERING ASSEMBLY USING LIFT CYLINDER CONTROL

- s) Repeat steps "e" through "r" until the desired number of connections are made up.

2. Breaking A Connection

- a) Ensure hydraulic power supply to the tong and backup is energized. The master link on the rigid sling must be used to suspend the tong. Do not suspend the tong directly from the rigid sling. See Illustration 2.I.1.
- b) Set the backing pin for "breakout" operation. Lift up on the backing pin and rotate it to the "breakout" position, which is 2 o'clock as seen from the front of the tong. The opening in the rotary gear must be aligned with the tong door opening in order to properly set the backing pin.



**Backing pin shown
in the break-out
position**

ILLUSTRATION 2.I.16: SETTING BACKING PIN TO "BREAK-OUT" MODE

- c) Pre-set the backup pressure before beginning your job. See Step 1 - d) of these operating procedures for detailed instructions for setting backup clamping pressure.
- d) Ensure the load cell is configured for break-out operation. See Section 2.F.3 of the SL-4500 Technical Manual for detailed instructions for configuring the load cell on your equipment.
- e) Transfer the snub line to the off-driller's side of the tong (the right-hand side as seen from the rear).
- f) Unlatch and open the tong door (see Illustration 2.I.6).
- g) Actuate the lift cylinder control valve to lift the assembly from the drill floor. Pushing the valve toward the center of the tong will retract the lift cylinder to lift the assembly (see illustration 2.I.7). Note that rig personnel are required to stabilize the tong and backup as it is being lifted so it does not swing and collide with other rig equipment.



RIG PERSONNEL MUST STABILIZE THE TONG AND BACKUP AS IT IS LIFTED FROM THE DRILL FLOOR

- h) Move the tong and backup assembly on to the tubing joint. Use the lift cylinder to ensure the assembly is at the correct height so that the backup jaws are located below the connection point, and the tong jaws are located above the connection joint.
- i) Close the tong door. Ensure the door is securely latched (tug on the door handle to ensure it remains latched).

Breaking A Connection (continued):

- j) Ensure tubing is roughly centered within the tong and backup jaws - rig personnel are required to stabilize the tong and backup around the connection until the jaws have been clamped shut. Actuate the backup clamping valve (push it toward the centre of the tong) to clamp the backup jaws on to the tubing below the connection point. Note that the backup control is "clamp and release", meaning that once the backup jaws are clamped, the jaws remain under clamping pressure until the operator manipulates the backup control handle to release pressure (see Illustration 2.1.8).
- k) The motor speed control valve may be in one of three positions:
 - UP - High speed selected
 - MIDDLE - Neutral position
 - DOWN - Low speed selected

Breakout torque is only available in the low-speed mode. If the motor speed control is not already in the "low speed" position grasp the motor speed control valve and firmly push down until it "latches" into its detent position. Gently pull the rotation control valve toward the operator to slowly rotate the cage plate until the tong jaws grip the tubing.

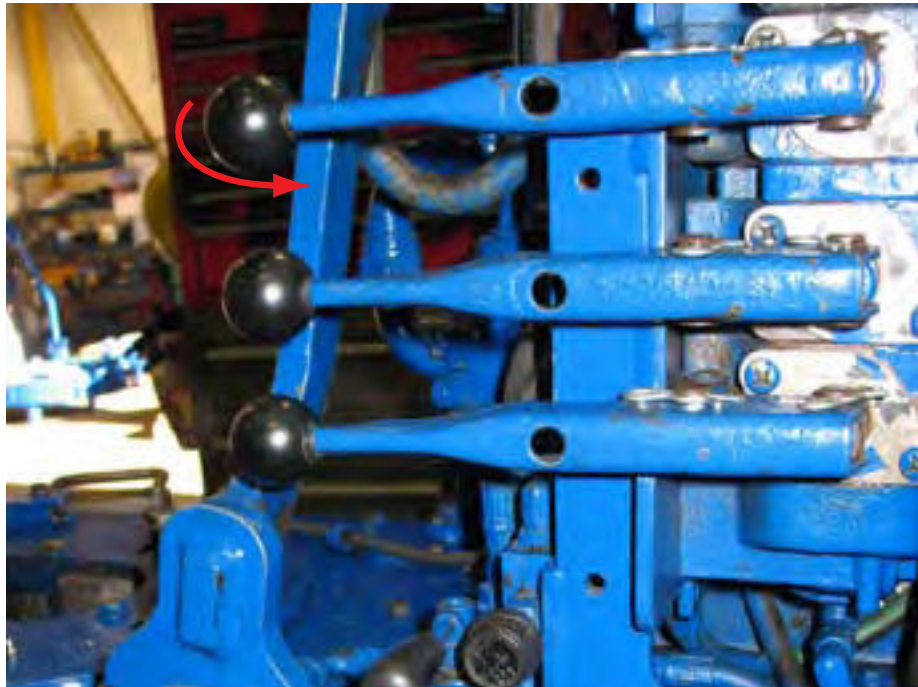

ILLUSTRATION 2.1.17: ROTATION CONTROL - BREAK-OUT

- l) Pull the rotation control handle all the way out to ensure full breakout torque is being delivered to the joint. When the joint releases, switch to high speed to completely un-thread the connection:
 - Do not release the rotation control
 - Grasp the speed control knob and firmly pull it all the way up to the high speed setting (see Illustration 2.1.18).
 Release the rotation control handle when the connection completely un-threads.

Breaking A Connection (continued):



ILLUSTRATION 2.I.18: SWITCHING MOTOR SPEED CONTROL TO HIGH SPEED

- m) Release the jaws from the tubing after the connection has been broken and un-threaded. Push the rotation control handle toward the centre of the tong to rotate the cage plate in the "makeup" direction and release the jaws from the tubing.

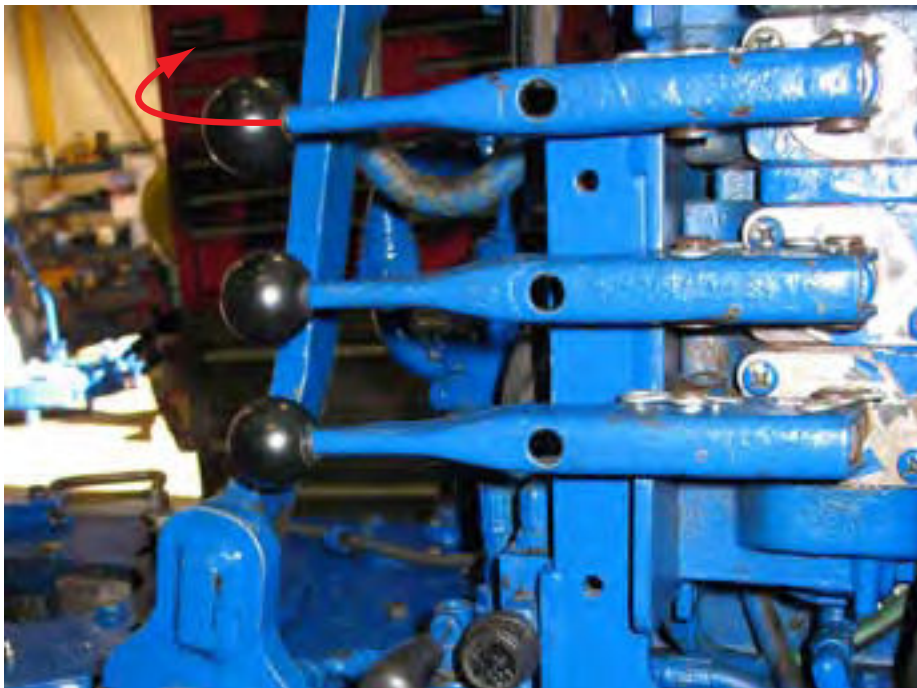

ILLUSTRATION 2.I.19: RELEASING TONG JAWS FOLLOWING BREAK OUT & UN-THREADING

Breaking A Connection (continued):

- n) When tong jaws are free release the backup jaws by pulling the backup clamp control handle away from the tong toward the operator.



ILLUSTRATION 2.1.20: UN-CLAMPING BACKUP JAWS

- o) Unlatch and open the tong door to free the assembly from the tubing. Note that rig personnel may be required to stabilize the equipment as it completely releases from the tubing. Guide the assembly away from the string and use the lift cylinder control to lower it to the drill floor.

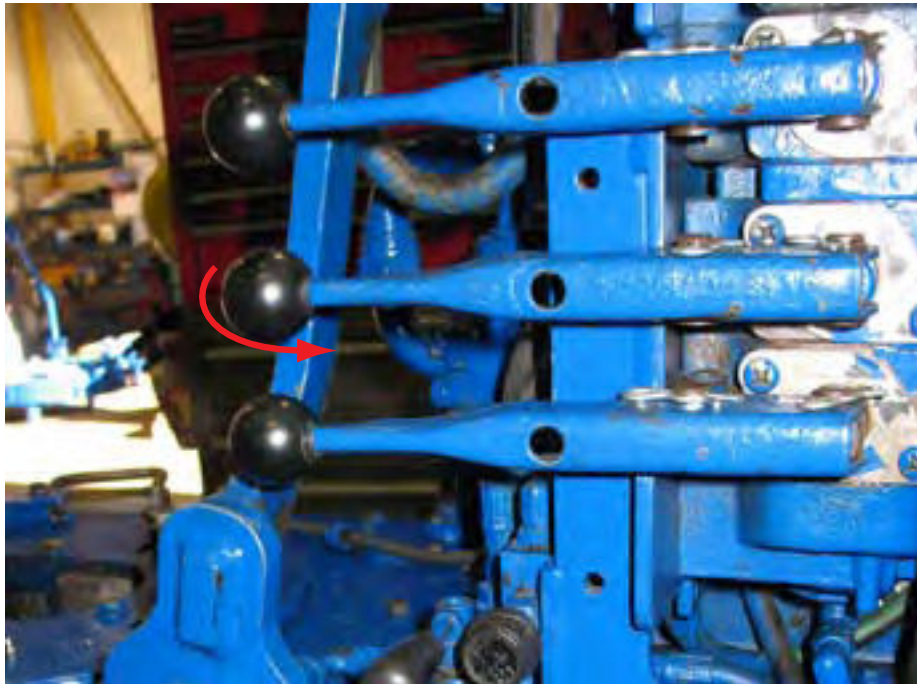

ILLUSTRATION 2.1.21: LOWERING ASSEMBLY USING LIFT CYLINDER CONTROL

- p) Use your rig's standard pipe handling procedures to remove and rack the freed tubing stand.
- q) Repeat steps "g" through "p" as many times as necessary to breakout and un-thread the desired number of connections.



***This page intentionally
left blank***

McCoy Completions & Drilling recognizes that minor on-site repairs and modifications are required to maintain peak operating condition of your equipment, or to match your equipment with the operating environment. Examples of minor repairs are

- replacement of damaged hydraulic hoses and fittings.
- replacement of malfunctioning pressure gauges and valves.
- replacement of door cylinders
- replacement of fasteners

Any replaced component must be an identical component supplied by McCoy Completions & Drilling. Replaced fasteners must be Grade 8 or equivalent, or whatever fastener is specified by McCoy.

A. GENERAL MAINTENANCE SAFETY PRACTICES

The practices identified here are intended as a guideline. All personnel are responsible for performing their tasks in a manner that ensures worker, equipment, and environmental safety, and may require taking additional steps that are not identified in this section.

Equipment maintenance shall be performed only by designated qualified maintenance personnel. Wear approved eye wear and footwear, and follow all of your company's safety guidelines. Do not begin a maintenance task without the proper tools or materials on hand, or the proper drawings and documentation necessary.

Schedule planned maintenance with operators to avoid conflicts, unnecessary downtime, and the danger of accidental equipment activation. Notify operations when maintenance procedures are complete and equipment functionality is restored.

Isolate the location of the maintenance under way to prevent unaware personnel from inadvertently exposing themselves to a hazard. Use tape, rope, or signage to clearly indicate "off-limits" area.

Replacement of large, heavy individual parts and/or heavy structural components must be performed using an approved lifting device of sufficient lifting capacity. Use care when attaching the lifting device, and safeguard area to avoid endangering personnel or equipment.

All spare parts must meet or exceed OEM specifications in order to maintain equipment integrity, especially protective equipment

McCoy recommends that disconnection of hydraulic connectors be performed with the power unit off and the hydraulic circuit depressurized.

Your equipment uses materials that may be harmful to the environment if improperly disposed of (hydraulic fluid, grease, etc.). Dispose of all materials according to your company's proscribed environmental protection regulations.

B. CLEANING

Clean tong thoroughly cleaned with a good petroleum-based cleaning agent after each job, prior to storage. Farr recommends that the motor and valve assembly be periodically removed, along with the top tong plate, so that guides, rollers and gears can be properly cleaned. Ensure that cleaning solvents and chemicals are captured to prevent environmental contamination, and dispose of all materials according to your company's proscribed environmental protection regulations.

C. PREVENTIVE MAINTENANCE PRACTICES

Regular maintenance programs are necessary, and must be established to assure safe, dependable operation of your Hydraulic Tubular Connection System and to avoid costly breakdown maintenance. The following maintenance procedures provide information required to properly maintain your equipment. Your equipment may require more, or less maintenance depending upon the frequency of use and the field conditions under which your equipment operates. McCoy has also provided recommended maintenance checklists. The intervals in the maintenance checklists are designed for equipment operating at 10°C to 35°C ambient temperature for 10 hours per day. McCoy recommends that the inspection and maintenance procedures in this section be performed as recommended in the maintenance checklists, or in conjunction with your maintenance foreman's experience and best estimate of when your equipment is due for this maintenance.

Purchased components included with your hydraulic tubular connection equipment (for example: motors, valves, etc.) may specify maintenance tasks and intervals over and above what McCoy recommends as part of their recommended procedures. Users of this equipment may choose to perform or ignore these additional tasks at their discretion.

Premature fouling of particulate filters within your prime mover or ancillary hydraulic power unit requires immediate hydraulic fluid laboratory analysis to prevent premature wear of hydraulic system due to high levels of wear metals in the fluid.

McCoy Completions & Drilling recommends tracking all maintenance activity including the lubrication schedule. This may be a simple as keeping a paper log, or using a software-based maintenance tracking utility. A maintenance log is a valuable tool that can be used for easily retrieving maintenance history or identifying trends that require correction.

D. LUBRICATION

Use a quality multipurpose bearing lubricant that will remain within its viscosity range at expected operating temperatures. In addition, Farr recommends the following lubrication procedure at the completion of each job prior to storage.

1. Cage Plate Rollers

The cage plate cam followers are sealed units, and do not require lubrication. However, the cage plate and rotary gear grooves in which the cam followers ride should be lightly greased. When the cage plate is rotated as a unit, the cam followers are exposed, and can be greased. Continue rotating the cage plate assembly until all cam followers, top and bottom, are greased.

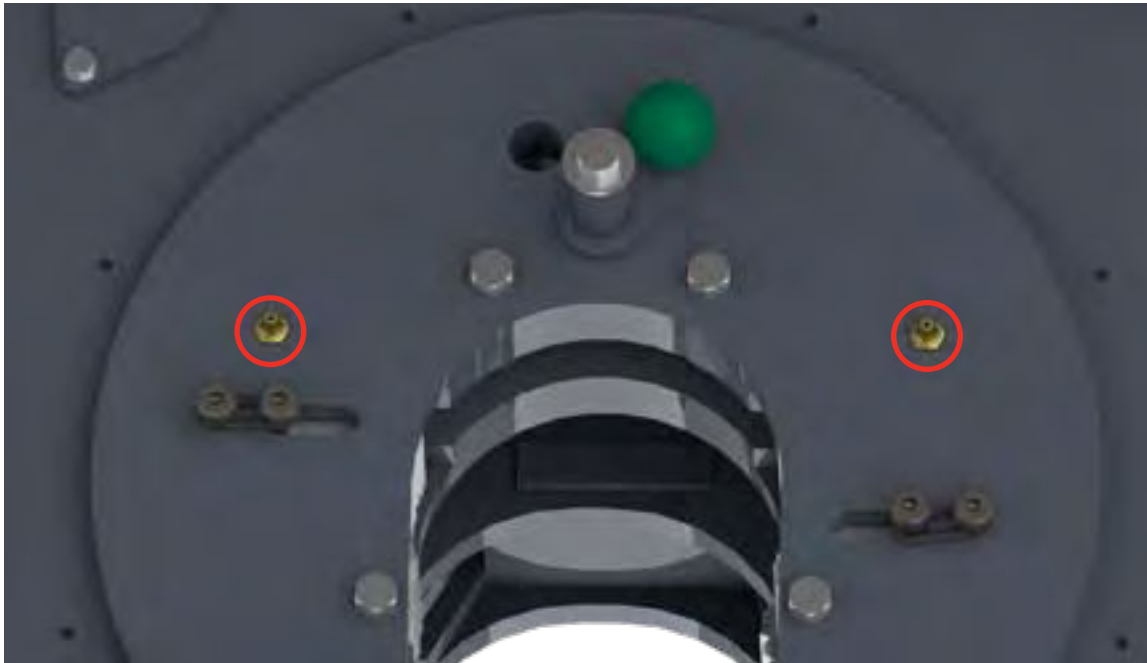

ILLUSTRATION 3.D.1: CAGE PLATE ROLLER LUBRICATION

2. Idler Shaft Bearings

Apply grease to these bearings through the grease fittings in the ends of the idler shafts, located on the top of the tong to the inside of each rigid sling weldment (3 locations total).

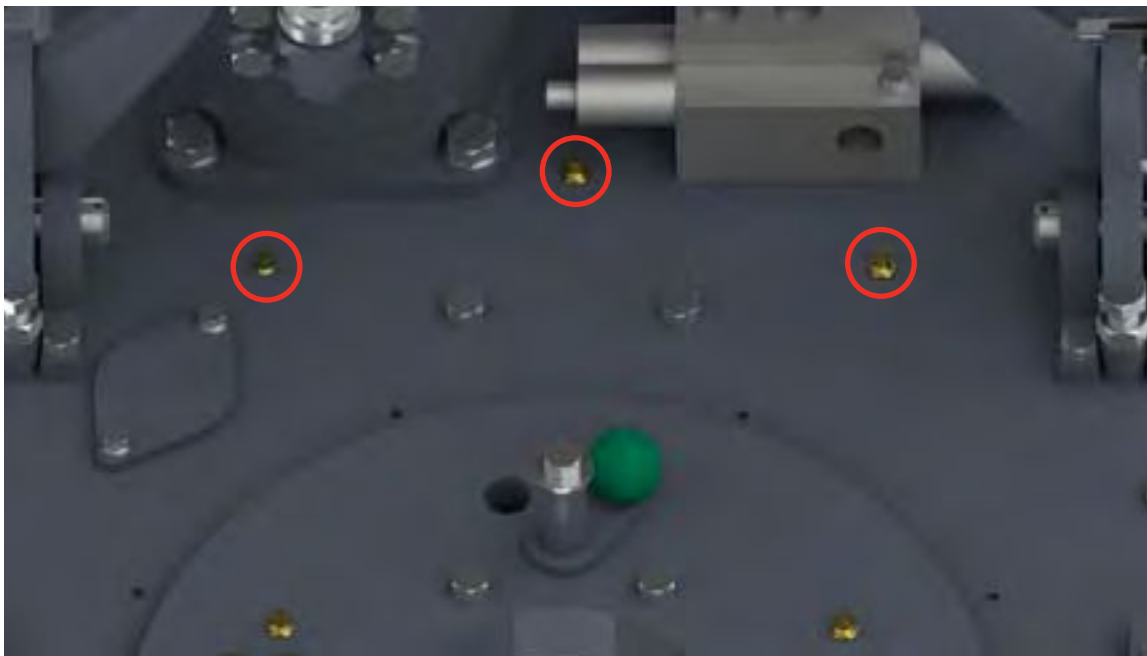

ILLUSTRATION 3.D.2: IDLER SHAFT BEARING LUBRICATION

3. Reduction Gear Bearings

Apply grease to these bearings through the grease fittings in the ends of the reduction gear shafts, located on the top of the tong directly under the main hydraulic support, and behind the motor (2 locations total).

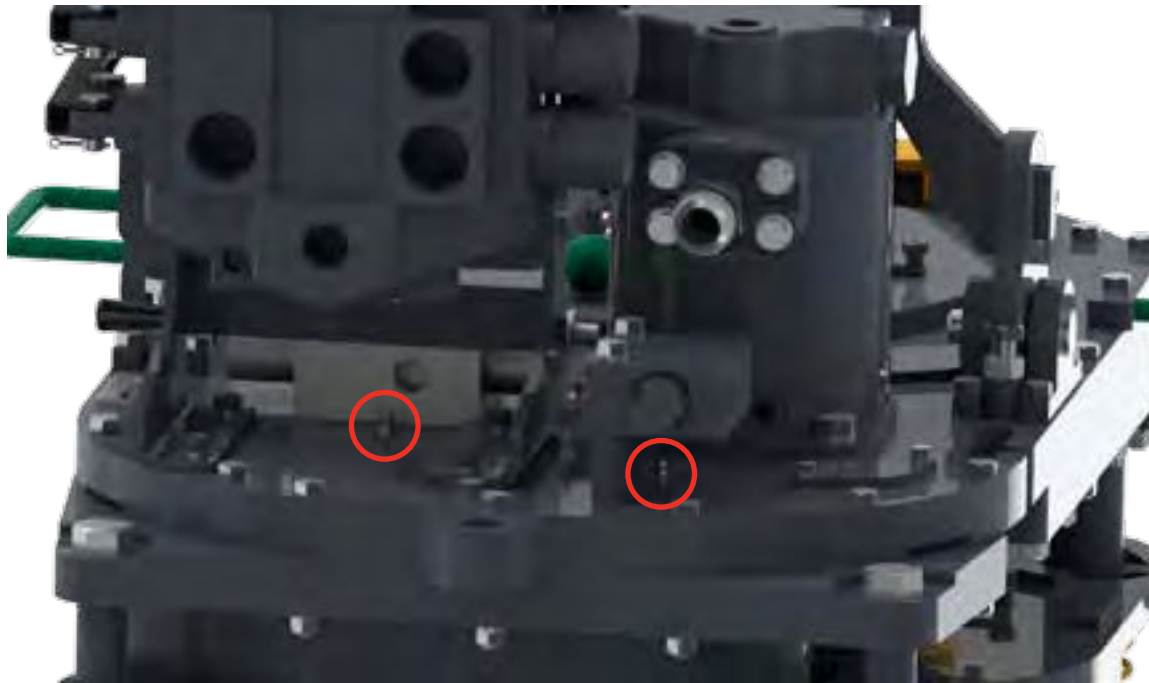

ILLUSTRATION 3.D.3: REDUCTION GEAR BEARING LUBRICATION

4. Tong Door Pivot Shaft

Apply grease to the tong door pivot shaft through the grease fitting in the end of the shaft.



ILLUSTRATION 3.D.4: DOOR PIVOT SHAFT LUBRICATION

5. Tong Door Latch

Apply a thin layer of grease to the tong door latch claws, and the top and bottom of the door latch post to enable smooth latching action.

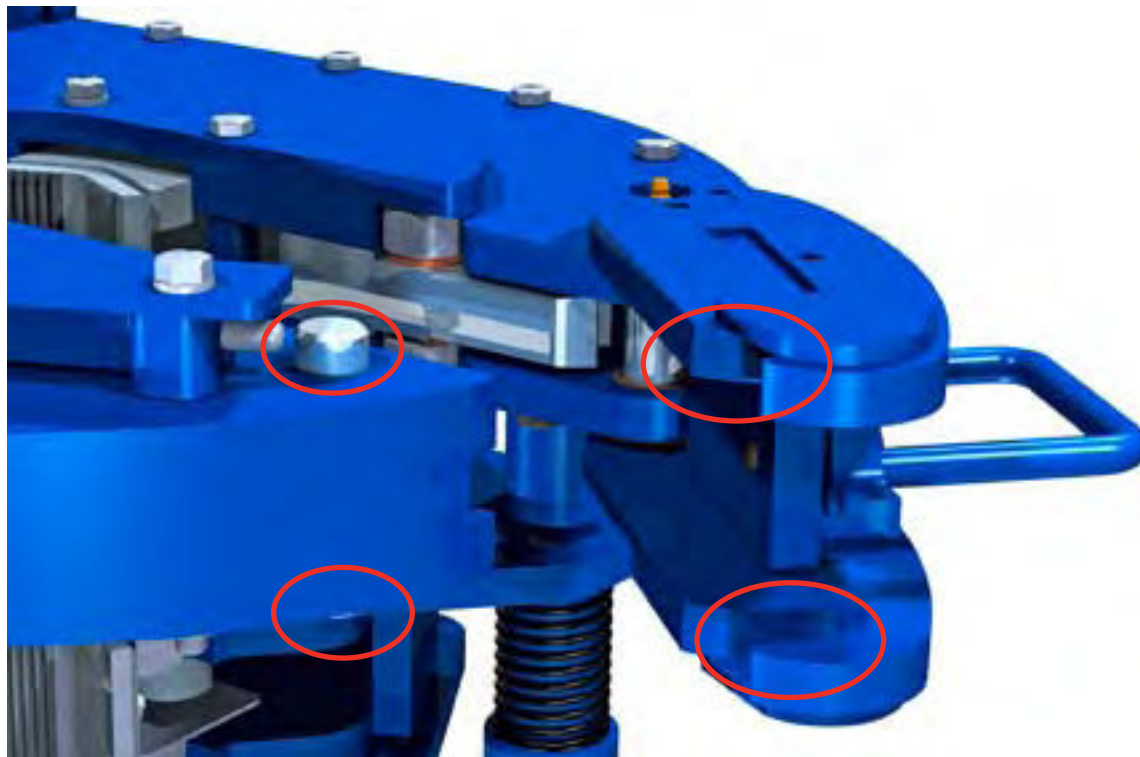

ILLUSTRATION 3.D.5: DOOR LATCH & POST LUBRICATION

6. Jaw Lubrication

Apply a thin layer of grease to the metal-to-metal contact surfaces of the tong and backup jaws to enable them to slide smoothly.

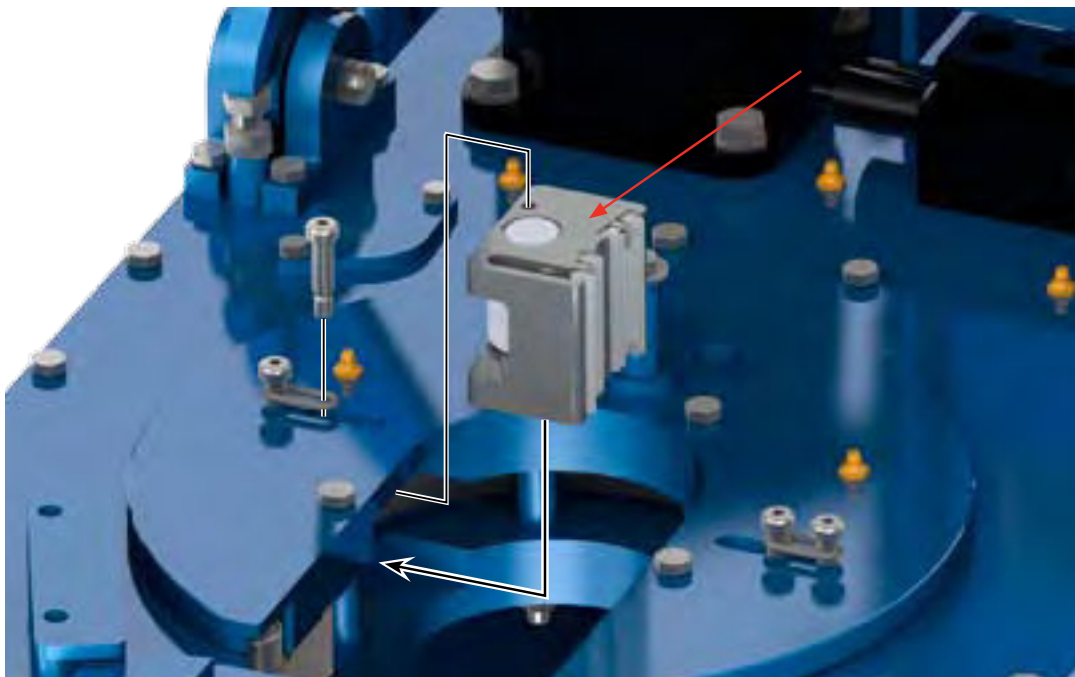

ILLUSTRATION 3.D.6: JAW ASSEMBLY LUBRICATION

7. Backup / Load Cell Lubrication

Grease must be added to both sides of the interface of the load cell and the rear leg of the backup.

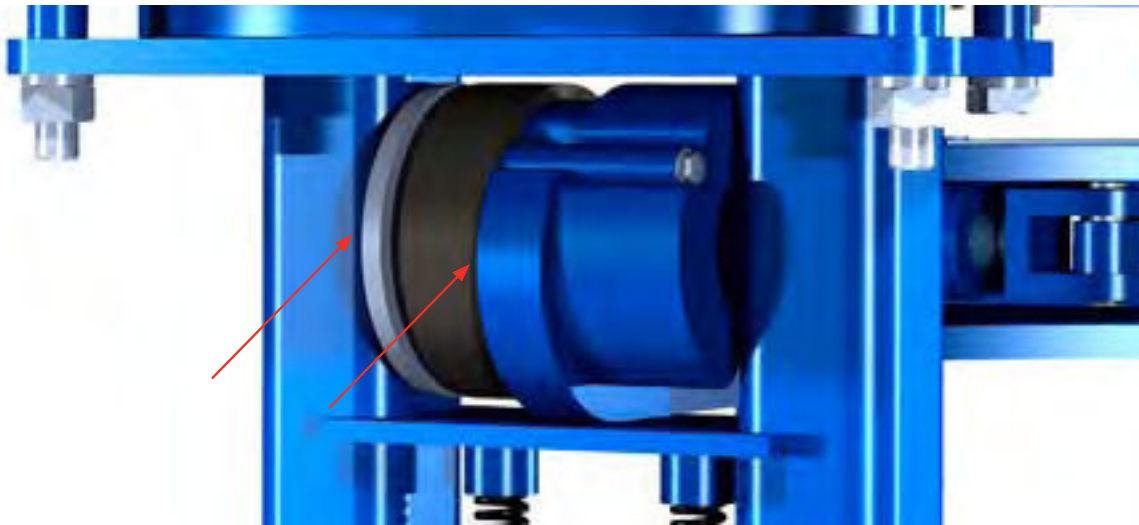

ILLUSTRATION 3.D.7: LOAD CELL LUBRICATION

E. ADJUSTMENTS

1. Brake Band Adjustment (See Illustration 3.E.1):

The brake bands must be periodically adjusted to continue to provide smooth and efficient jaw cam action. If the cage plate turns with the rotary gear, the jaws will not cam properly and, therefore, will not bite on the tubing or casing. Tightening the brake band against the cage plates will increase frictional resistance, allowing jaws to cam properly and grip the casing. Adjust the brake band using the adjustment nut and bolt set as shown in the illustration below. Do not over tighten, as this causes excessive wear to the brake bands.

If excessive tightening is required for tong operation, remove the brake band and inspect for wear or foreign debris/excessive grease. Cleaning may be required to restore the brake lining. Replace the brake band if the thickness is less than .10" (2.5mm) at any effective portion of the brake lining.

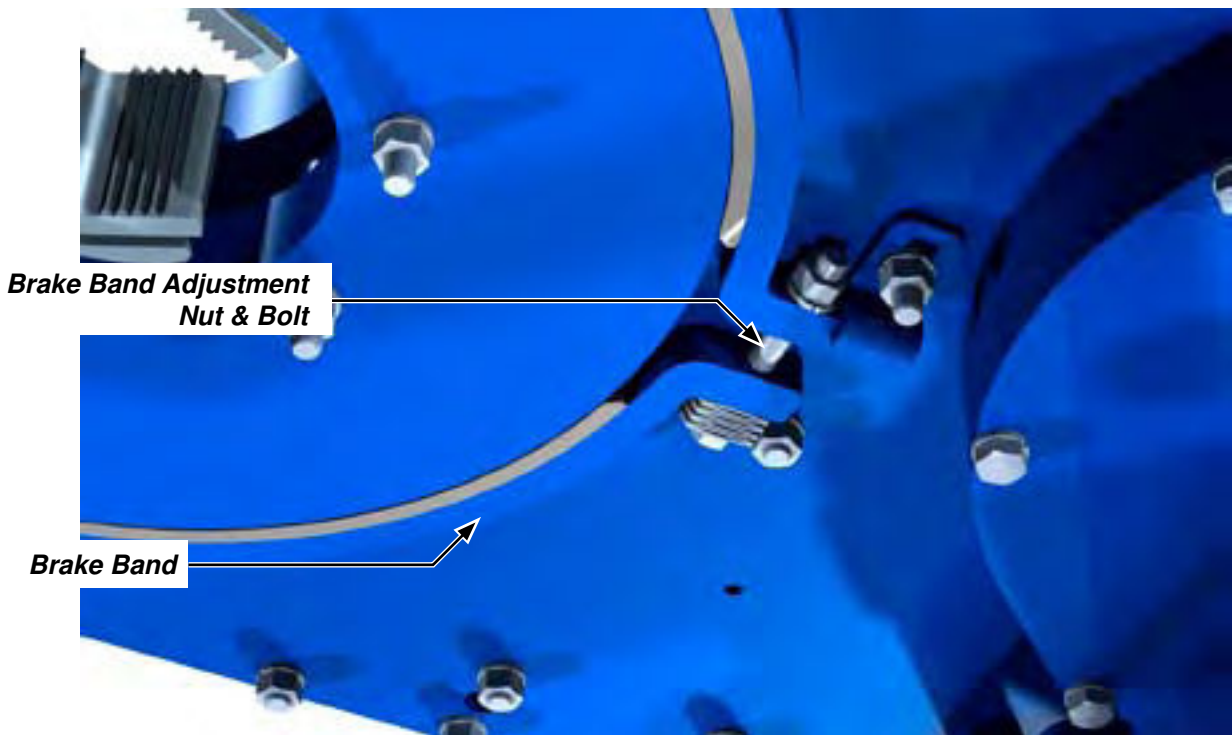

ILLUSTRATION 3.E.1: BRAKE BAND ADJUSTMENT

2. Safety Door Switch Adjustment:

The safety door switch is intended to interrupt hydraulic power to the motor when the tong door is opened, or even slightly ajar. This is a critical safety system, and proper adjustment is necessary to maintain the intended function. If the rotary gear does not immediately and completely stop rotating when the door is opened, remove the tong from service and perform the following adjustments:

1. Set the tong up in a controlled testing environment without connecting hydraulic power.
2. Open the tong door and check operation of the safety door switch plunger. Depress and allow it spring back several times to ensure smooth operation. If the plunger binds or jams, remove the control cable guide mount at the door end, remove the control cable and plunger, and thoroughly clean and lubricate the plunger and control cable before reinstalling.
3. Test the control cable after cleaning and reinstallation. The cable end should spring back when depressed. If the cable does not smoothly spring back, replace the control cable.
4. Following reinstallation the plunger should extend 3/4 of an inch from the end of the control cable guide mount.



ILLUSTRATION 3.E.2: SAFETY DOOR PLUNGER ADJUSTMENT 01

Adjust plunger position using the positioning nut and locking nut on the control cable before proceeding. Loosen the locking nut, and adjust the positioning nut until the plunger extension measures approximately 3/4". When position of the plunger is set, tighten the locking nut. Note that although the following illustration shows the tong door closed, the plunger extension must be performed with the door open.



ILLUSTRATION 3.E.3: SAFETY DOOR PLUNGER ADJUSTMENT 02

Safety Door Switch Adjustment Cont'd:

5. Connect hydraulic power to the tong.
6. Ensure the door is closed and all personnel are clear. Begin rotating the cage plate. Open the tong door - the cage plate should immediately and completely stop.
7. Release all controls, and close the tong door again. Ensure the cage plate rotates with the door closed.
8. If cage plate continues to rotate with the door open, further adjustment of the safety door switch is necessary. Remove hydraulic power from the tong.
9. Adjust the guide block first. Slightly loosen the two mounting bolts, and use a hammer to lightly tap the guide block toward the front of the tong. Adjust the block approximately 1/8" of an inch, and retighten the mounting bolts.

**ILLUSTRATION 3.E.4: SAFETY DOOR PLUNGER ADJUSTMENT 03**

10. Repeat steps 5 through 8.
11. Make another adjustment of the guide block. Once the adjustment block can no longer be adjusted, further adjustment must be made using the cable positioning nuts (see Step 4).
12. Repeat steps 5 through 11 as many times as necessary to properly adjust the safety door switch. Once the switch has been satisfactorily adjusted the tong may be returned to service.

F. RECOMMENDED PERIODIC CHECKS**1. Backing Pin**

Perform a visual inspection of the backing pin after each job. Replace the pin if stress cracks or excessive wear is found, or if either pin is bent.

2. Torque Gauge

Periodic calibration of the torque gauge is recommended to assure accurate torque readings. When having the torque gauge serviced and calibrated, it is critical to note the arm length of the tong, as indicated in the "Specifications" section. Farr recommends that the torque gauge assembly be calibrated yearly.

G. OVERHAUL PROCEDURES

The tong may be overhauled following the disassembly instructions in the following procedure. Access to the gear train is possible by removing the top plate of the tong.



ALL MAINTENANCE AND OVERHAUL SHOULD BE PERFORMED FROM THE TOP. THE BOTTOM PLATE OF THE TONG IS TYPICALLY WELDED TO THE SIDE BODY AND CANNOT BE REMOVED.



REPLACEMENT FASTENERS (BOLTS, NUTS, CAP SCREWS, MACHINE SCREWS, ETC.) USED DURING MAINTENANCE OR OVERHAUL MUST BE GRADE 8 OR EQUIVALENT.

1. Disconnect all hydraulic lines from the hydraulic valve assemble, including main motor lines, backup, safety door, and drains.
2. Remove the four 3/8" hex cap screws securing the valve assembly to the top plate, and lift valve assembly away.
3. If not already done, disconnect and remove load cell and load cell spacer weldment.

REMOVAL OF BACKUP

4. Construct a support that will support the entire weight of the backup assembly.
5. Lift the tong and backup and lower onto structure constructed in step 1 until the weight of the backup is completely removed from the front leg and rear support springs.
6. Free the front leg springs by removing the 3/8" hex cap screw that supports the bottom spring spacers. Remove the cotter pins securing the rear leg support rod, and remove the support rod.
7. Lift the tong, and front and rear legs, up and away from the backup. Use caution not to lose the springs and top spring washers, which will come loose from the front legs when the tong is lifted.

REMOVAL OF LEG ASSEMBLIES

8. Set the tong and leg assembly onto a flat surface. Ensure that the majority of the weight remains supported by the rigid sling and the crane. Remove the two 3/4" x 5" hex bolts, lock washers, and 3/4" nuts securing the rear of the rear leg assembly, and the two 3/4" x 3-1/2" hex bolts and lock washers securing the front of the rear leg assembly.
9. Remove the fasteners securing each front leg mount to the bottom plate.
10. Lift the tong up and away from the legs - ensure that none of the leg assemblies or weldments topple over when the tong is lifted away. Place the tong on a suitable surface that will support the entire weight of the tong and allow access to the bottom of the tong.
11. Remove the two eight 3/8" x 3-1/2" cap screws, lock washers, and nuts securing the rigid sling assembly to the top plate (four per side). The entire rigid sling assembly may now be lifted away from the tong.

REMOVAL OF TOP PLATE

12. If not already done, complete the disconnection of all hydraulic lines from the motor. Remove the four 1/2" cap screws securing the motor to the top plate, and lift the motor and motor gear away.
13. If not already done, remove the two jaw assemblies from the tong.
14. Remove the two external snap rings from the door pivot shaft. Remove the door pivot shaft - if necessary, use a hammer and a soft metal drive to tap the shaft out. Remove the door assembly.
15. Remove the door latch shaft the same way the pivot shaft was removed.
16. Ensure the safety door push-pull cable has been freed at the hydraulic valve end. Remove the fasteners securing the safety door actuator and push-pull assembly to the top plate, and remove the entire actuator assembly.



THE CAGE PLATE BOLTS ARE THE ONLY ITEMS FASTENING THE BOTTOM CAGE PLATE TO THE TONG. SUPPORT THE BOTTOM CAGE PLATE FROM BELOW PRIOR TO REMOVING CAGE PLATE BOLTS IN ORDER TO PREVENT DAMAGE TO THE BOTTOM CAGE PLATE OR PERSONAL INJURY TO THE MECHANIC

17. Remove the four cage plate bolts, washers, and nuts, and the four cage plate spacers. The cage plates may now be removed. There is no need to remove the backing pin assembly from the top cage plate unless maintenance on the backing pin is required.
18. Remove the two 3/8" x 3-1/2" bolts from the center of the tong, just behind the cage plate opening. Note that one of these two bolt sets secures the brake band retainer to the bottom plate.
19. Remove the three 3/8" x 5" hex bolts, 3/8" lock washers, and 3/8" hex nuts that secure the bottom gearbox cover to the top plate.

Overhaul Procedures (continued):

20. Remove the remainder of the 3/8" nuts and bolts from around the perimeter of the tong. Once the bolts are removed the top and bottom plate may be split apart - use caution to pull the top plate straight up from the bottom plate so that there is no binding on the dowel pins used for positioning.
21. For additional access to the gear train, the bottom gearbox cover may be removed by removing the remaining fasteners securing it to the bottom plate.

H. ASSEMBLY PROCEDURES

Assembly of Farr Hydraulic Power Tongs is simple, and can be accomplished without the use of special tools. The instructions on this page are presented as a guide only, and are similar to the assembly sequence our technician would use while assembling the tong in our plant.

REFER TO THE FOLLOWING TORQUE SPECS WHEN TIGHTENING HEX BOLTS AND HEX HEAD CAP SCREWS.

TIGHTENING TORQUE GUIDE			
SAE GRADE 8 - FINE THREAD			
SIZE	CLAMP LOAD	PLAIN	PLATED
1/4 - 28 (.250)	3,263	14 ft. lbs.	10 ft. lbs.
5/16- 24 (.3125)	5,113	27 ft. lbs.	20 ft. lbs.
3/8 - 24 (.375)	7,875	49 ft. lbs.	37 ft. lbs.
7/16 - 20 (.4375)	10,650	78 ft. lbs.	58 ft. lbs.
1/2 - 20 (.500)	14,400	120 ft. lbs.	90 ft. lbs.
9/16 - 18 (.5625)	18,300	172 ft. lbs.	129 ft. lbs.
5/8" - 18 (.625)	23,025	240 ft. lbs.	180 ft. lbs.
3/4 - 16 (.750)	33,600	420 ft. lbs.	315 ft. lbs.
7/8" - 14 (.875)	45,825	668 ft. lbs.	501 ft. lbs.
1 - 12 (1.000)	59,700	995 ft. lbs.	746 ft. lbs.
1 - 14 (1.000)	61,125	1019 ft. lbs.	764 ft. lbs.
1 1/8 - 12 (1.125)	77,025	1444 ft. lbs.	1083 ft. lbs.
1 1/4 - 12 (1.125)	96,600	2012 ft. lbs.	1509 ft. lbs.
1 3/8 - 12 (1.375)	118,350	2712 ft. lbs.	2034 ft. lbs.
1 1/2 - 12 (1.500)	142,275	3557 ft. lbs.	2668 ft. lbs.
SAE GRADE 8 - COARSE THREAD			
SIZE	CLAMP LOAD	PLAIN	PLATED
1/4 - 20 (.250)	2,850	12 ft. lbs.	9 ft. lbs.
5/16- 18 (.3125)	4,725	25 ft. lbs.	18 ft. lbs.
3/8 - 16 (.375)	6,975	44 ft. lbs.	33 ft. lbs.
7/16 - 14 (.4375)	9,600	70 ft. lbs.	52 ft. lbs.
1/2 - 13 (.500)	12,750	106 ft. lbs.	80 ft. lbs.
9/16 - 12 (.5625)	16,350	153 ft. lbs.	115 ft. lbs.
5/8" - 11 (.625)	20,325	212 ft. lbs.	159 ft. lbs.
3/4 - 10 (.750)	30,075	376 ft. lbs.	282 ft. lbs.
7/8" - 9 (.875)	41,550	606 ft. lbs.	454 ft. lbs.
1 - 8 (1.000)	54,525	909 ft. lbs.	682 ft. lbs.
1 1/8 - 7 (1.125)	68,700	1288 ft. lbs.	966 ft. lbs.
1 1/4 - 7 (1.125)	87,225	1817 ft. lbs.	1363 ft. lbs.
1 3/8 - 6 (1.375)	103,950	2382 ft. lbs.	1787 ft. lbs.
1 1/2 - 6 (1.500)	126,450	3161 ft. lbs.	2371 ft. lbs.



ALL FASTENERS USED DURING REASSEMBLY OF LOAD-BEARING COMPONENTS (CHAIN SLINGS, RIGID SLINGS, BACKUP LEGS) MUST BE TIGHTENED TO THE CORRECT TORQUE. THREADED FASTENERS USED IN LOAD-BEARING DEVICES MUST BE SECURED WITH RED LOC-TITE™.

NOTE ON INSTALLATION PRACTICES: Ensure all bearings are liberally greased before installing over a shaft or into gears or bearing caps. When inserting a shaft through a support roller assembly ensure shaft is greased. Also ensure all meta-to-metal contact in the gear train is adequately greased.

When graphics are not used in the assembly process, please refer to the relevant exploded diagrams in Section 5.

1. Position the tong body gear case on a suitable stationary support such that the bottom body plate is accessible.
2. Assemble seven inner ring / needle bearing assemblies - press seven inner rings into seven needle bearings.
3. Press one of the bearing assemblies assembled in step 2 into large reduction gear (PN 101-3292) followed by a bearing spacer (PN 101-3812) and a second bearing assembly.
4. Orient the gear assembly from step 3 so that the smaller gear is facing up. Slide gear shaft (PN 101-3296) into the gear assembly, making sure the threaded hole in the top of the shaft is facing up, centering in the gear assembly as best as able.
5. Place a thrust washer (PN 02-E0001) over each end of the gear shaft, and then place the bottom (non-threaded) end of the gear shaft into the gear box cover (PN 101-3317).
6. Place three 3/8" x 3/4" dowel pins in to their respective locations in the side wall of the gearbox cover, and fasten the gearbox cover to the bottom of the bottom plate with four 3/8" NC x 2-1/2" hex cap screws and 3/8" lock washers



ILLUSTRATION 3.H.1: GEARBOX COVER INSTALLATION

7. Press one of the bearing assemblies assembled in step 2 into the smaller reduction gear (PN 101-3291) followed by a bearing spacer (PN 101-3812) and a second bearing assembly.
8. Orient the gear assembly from step 7 so that the smaller gear is facing down. Slide gear shaft (PN 101-3296) into the gear assembly, making sure the threaded hole in the top of the shaft is facing up, centering in the gear assembly as best as able.
9. Place a thrust washer (PN 02-E0001) over each end of the gear shaft, and then place the bottom (non-threaded) end of the gear shaft into the gear box cover (PN 101-3317).
10. Press one bearing assembly assembled in Step 2 into each of the three idler gears (PN 101-3293). Slide an idler gear shaft (PN 101-3297) through each idler gear assembly and center in the gear assemblies as well as able. Slide a thrust washer (PN 02-E0001) over each end, and place the bottom (un-threaded) ends of the shafts through the bottom plate (see Illustration 3.H.2).

Mechanical Assembly Procedures (continued):

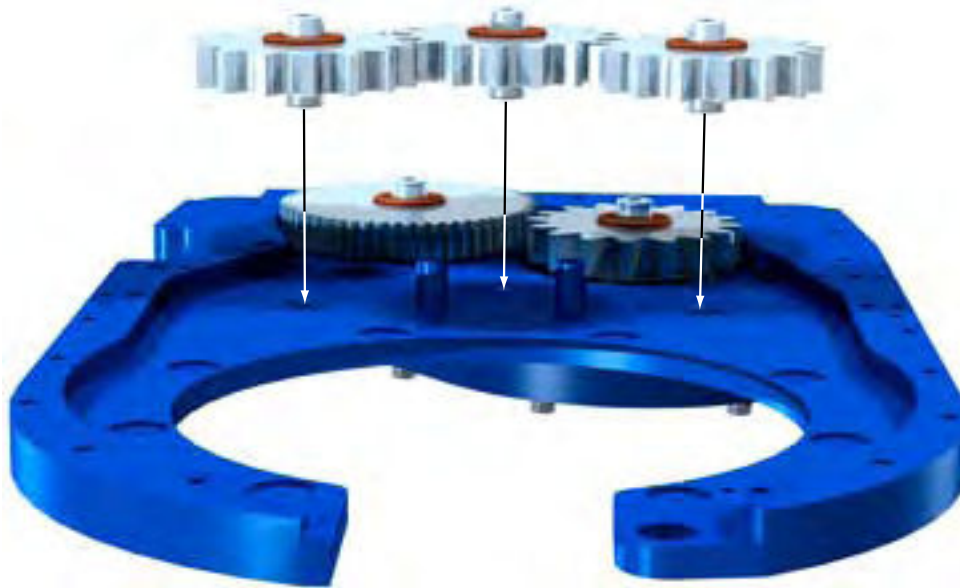

ILLUSTRATION 3.H.2: IDLER GEAR INSTALLATION

11. Assemble rotary gear assembly gear as shown in Illustration 3.H.3. Refer to assembly drawing on page 5.12 for further information.

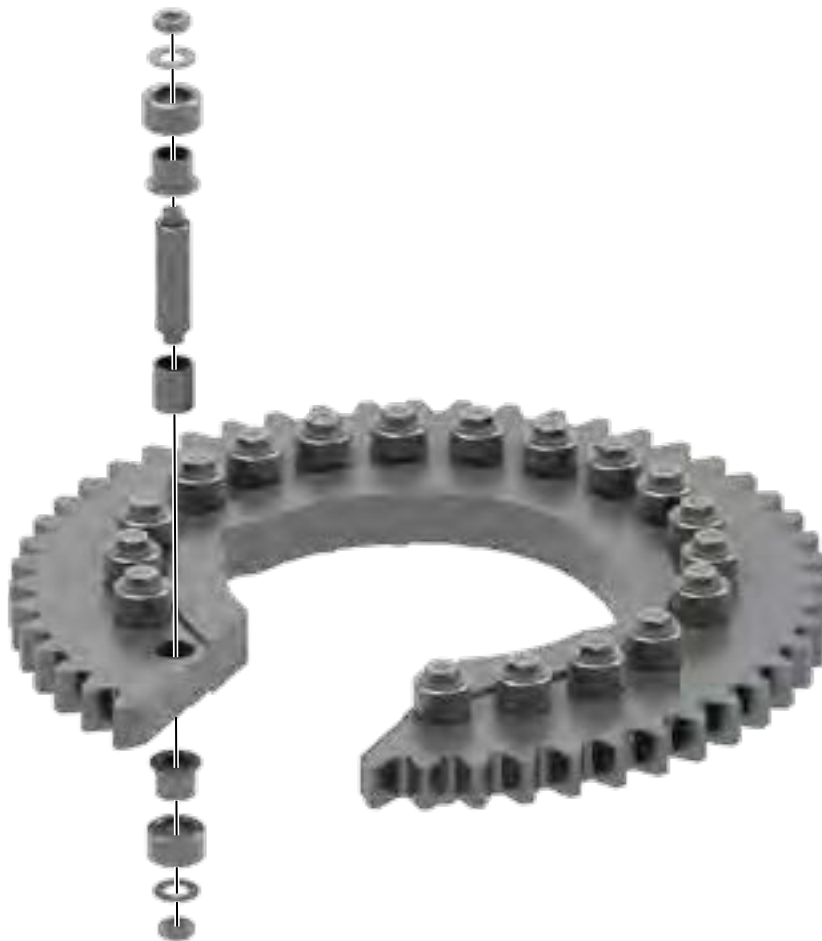

ILLUSTRATION 3.H.3: ROTARY GEAR ASSEMBLY

Mechanical Assembly Procedures (continued):

12. Install eight "button" guides (PN 101-3389) into the bottom plate using one 1/4" NC x 1/2" hex socket flat head machine screw per button. Install the remaining eight "button" guides on the underside of the top plate.

**ILLUSTRATION 3.H.4: "BUTTON GUIDE" INSTALLATION**

13. Install rotary gear assembly over the "button" guides in the lower plate. Ensure the rotary gear is installed with the backing pin slots facing up.
14. Insert three 3/8" x 1" dowel pins into their respective locations in the lower body plate.
15. Lower the top plate into position over the bottom plate. Ensure the plate is lowered as horizontally as possible to prevent binding on the dowel pins.
16. Secure the top plate to the bottom plate and gear box with 3/8" NC x 3" hex cap screws (indicated by green) and 3/8" NC x 5" hex cap screws (indicated by red), and 3/8" NC hex nuts and 3/8" lock washers.

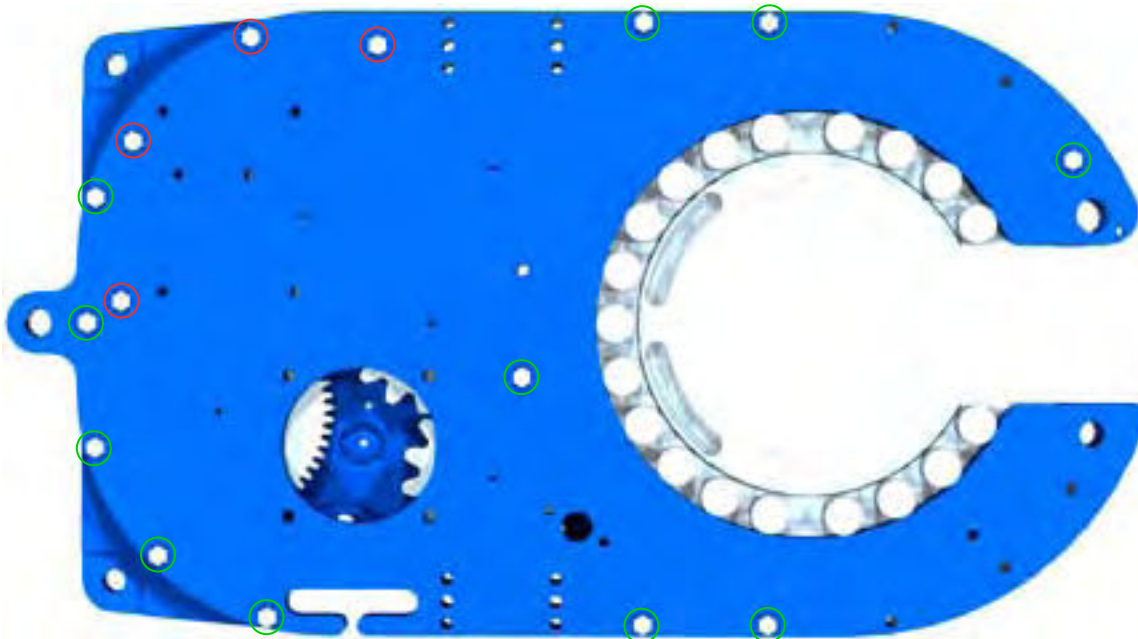
**ILLUSTRATION 3.H.5: MAIN BODY FASTENER PLACEMENT**

17. Position the lower cage plate (PN 101-3304) against the bottom side of the rotary gear assembly, ensuring the groove in the cage plate engages with the lower rollers. Place four cage plate spacers (PN 101-3333) on the inside of the bottom cage plate.

Mechanical Assembly Procedures (continued):

18. Place the top cage plate (PN 101-3303) over the top of the rotary gear assembly, ensuring the groove in the cage plate engages the rollers on the top of the rotary gear. Secure the top and bottom cage plates with four 3/8" NC x 4-1/2" hex cap screws, lock washers, and hex bolts.
19. Attach the motor gear to the motor shaft. Orient the motor gear so that the smaller diameter of the gear is toward the motor rather than the end of the motor shaft. The gear should be positioned 7/16" from the flat end of the motor shaft - secure with two 1/4" NC x 3/8" cone point hex socket head set screws.
20. Slide the motor thrust washer (PN 02-E0009) over the end of the motor shaft. Mount the motor to the top plate - the end of the motor shaft should rest within the circular cutout in the bottom plate. Secure the motor to the top plate with four 1/2" NC x 1-1/2" hex cap screws and 1/2" lock washers.
21. Insert the door latch pin (PN 101-3306) into its location and secure on the insides of the top and bottom plate with two external snap rings (PN 02-E0004).
22. Attach the door latch weldment to the door weldment (see Illustration 3.H.6):
 - i. Insert a positioning 1/4" x 3/4" dowel pin into the front of the door weldment
 - ii. Slide the latch spring (C0460-0050-1125) over the pin welded to the front of the bottom door plate in the door weldment.
 - iii. Attach the latch weldment (PN 101-3530) to the door weldment with a 3/8" x 3/4" hex socket shoulder bolt. Ensure a wave spring (PN 02-9267) is inserted between the latch weldment and the door weldment when the latch weldment is being attached.

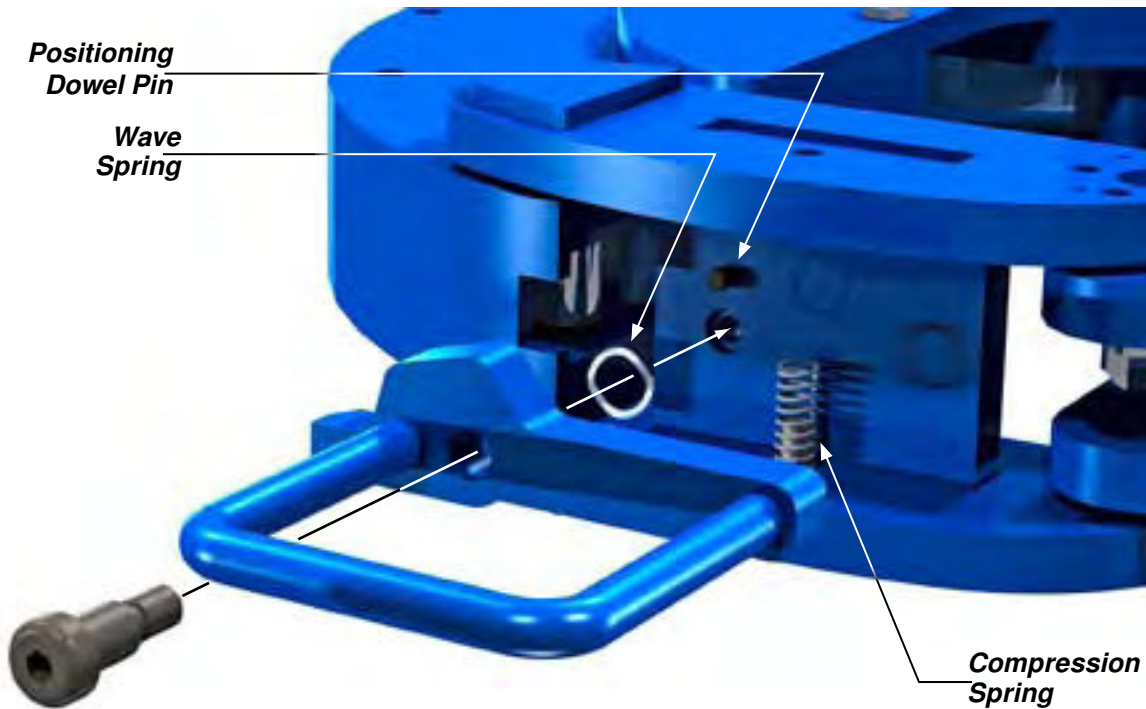
**ILLUSTRATION 3.H.6: DOOR LATCH WELDMENT INSTALLATION**

23. Insert a shoulder bushing (PN 02-E0003) into the top of the top plate, and the bottom of the bottom plate, where the door pin is located.

Mechanical Assembly Procedures (continued):

24. Thread the door detent into the bottom of the top plate until the spring-loaded button protrudes through the top plate. Secure the detent from the bottom with a 3/8" NC hex nut.

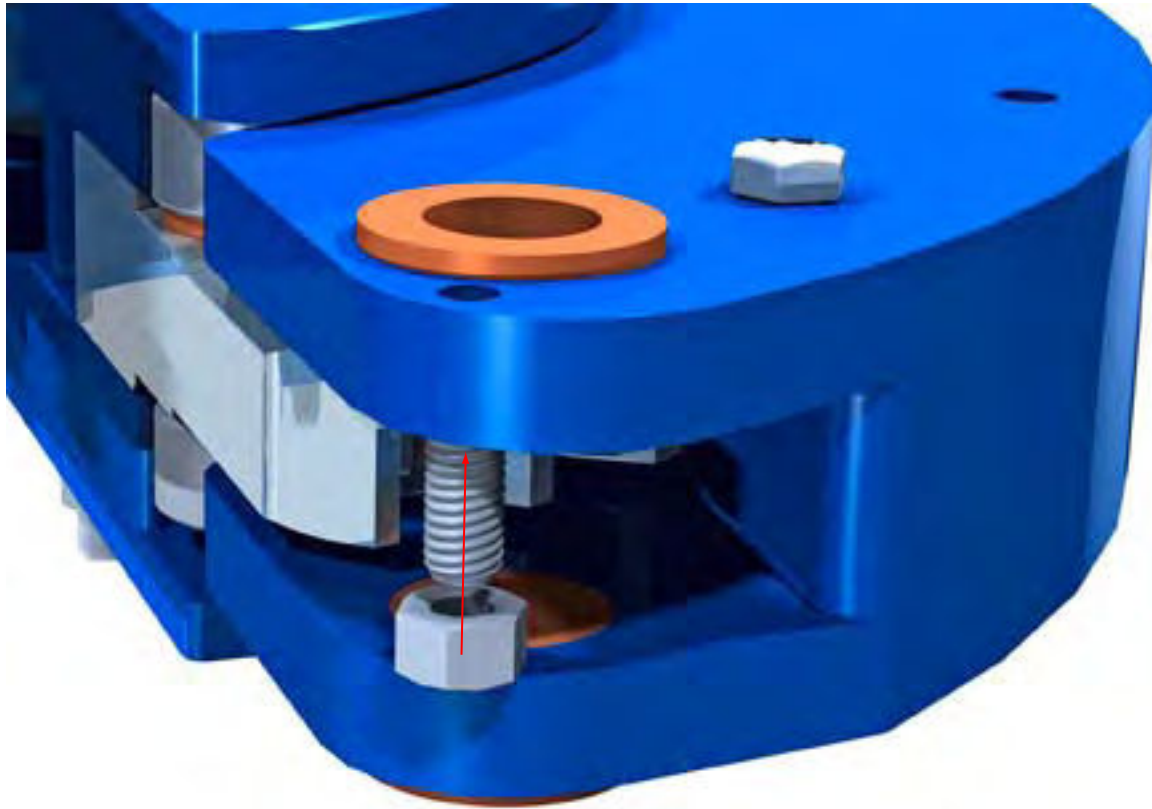

ILLUSTRATION 3.H.7: DOOR DETENT INSTALLATION

25. Position the door & latch assembly assembled in Step 22 in its location, and insert the door pin from the top through the door, the shoulder bushings, and the top and bottom plate. Secure the door pin with two 3/4" external snap rings (PN 02-E0004) to the insides of the shoulder bushings.
26. Attach the safety door cable guide holder (PN 101-4235) and cover (PN 101-4237) to the top plate with one 3/8" NC x 1-3/4" hex cap screw and 3/8" lock washer, and one 3/8" NC x 4-1/2" hex cap screw and lock washer. Note that the second fastener extends through the top and bottom plates and is secured on the bottom with a 3/8" lock washer and 3/8" NC hex nut.
27. Connect the two brake band weldments together, using a 3/8" NC x 3-1/4" hex cap screw, 3/8" lock washer, and 3/8" NC hex nut. Ensure that a Belleville 8-washer assembly (PN 101-3272ASSEM) is placed between the head of the cap screw and the brake band weldment.
28. Secure the brake band assembly to the bottom plate using two 3/8" x 16/25" shoulder bolts at the brake band pivots, and the brake band retainer (101-3975). Secure the brake band retainer to the bottom plate using a 3/8" NC x 3-1/2" hex cap screw, inserted from the top plate, a 3/8" lock washer, and a 3/8" NC hex nut.
29. Secure four rigid sling lifting lugs to the top plate using two 3/8" NC x 3-1/2" hex cap screws, two 3/8" lock washers, and two 3/8" NC hex nuts per lug (secure bolts from underneath the tong).
30. Slide the backing pin retainer (PN 101-4040) over the backing pin center pivot spacer (PN 101-4038), and secure the pivot spacer to the top cage plate using a 3/8" NC x 2-1/2" hex cap screw and 3/8" flat washer.
31. Thread 3/8" NC x 1-1/2" threaded stud (PN 101-4058) into the backing pin (PN 101-4039). Attach the backing pin to the backing pin retainer using the backing pin knob (PN 02-0017).
32. Attach the rigid sling weldment to the rigid sling brackets using one rigid sling pin (PN 02-E0008) per side. Secure each rigid sling pin with a 0.125" x 2.5" hitch pins. Ensure a 3/4" flat washer is installed between the rigid sling weldment and each rigid sling lug (total of four).
33. Set the rear leg weldment (PN 101-3883) on a flat concrete surface, in a clear area as close to the tong assembly as possible. Lift the tong with a crane, and lower it on to the rear leg weldment, ensuring most of the weight remains supported by the crane. Secure the rear leg weldment to the tong using two 3/4" NC x 5" hex bolts, 3/4" lock washers, and two 3/4" hex nuts through the two mounting holes in the rear, one 3/4" NC x 3-1/2" hex bolt and 3/4" lock washer, and one 3/4" NC x 2-1/2" hex bolt and 3/4" lock washer.

Mechanical Assembly Procedures (continued):

34. Attach the front leg weldments to the tong using two 3/8" NC x 3-1/2" hex cap screws, 3/8" lock washers, and 3/8" NC hex nuts per side.
35. Support the backup on a structure that will support its complete weight, at least 16 inches (40 cm) off the floor.
36. Set the tong and leg assembly down over the backup, guiding the front legs through the front leg holes on the backup and guiding the rear "paddle" on the backup between the uprights in the rear leg weldment. Before the front legs reach the floor, slide a large, 1-5/8" washer over the bottom of each leg followed by a front leg spring (PN 02-0920) and a bottom spring support (PN 101-4339). Secure the leg springs with a 3/8" NC x 2" hex cap screw and 3/8" NC hex nut.
37. Insert two backup support plate weldments (PN 101-3885) between the uprights in the rear leg weldment so that they oppose each other (see exploded diagram Pp. 6.28 - 6.29). Insert two rear leg springs (PN 997-13) between the two support plates, and insert the rear leg support rod (PN 101-3891) beneath the two plates. Secure the rod with two small hitch pins.
38. Lift the tong and backup assembly away from any supporting structures and place flat on a sturdy surface.
39. Pre-mount the main valve bank to the valve mount weldment (PN 101-4101) using three 1/2" NC x 4-1/2" hex bolts, 1/2" narrow flat washers, and 1/2" NC thin nylock nuts.
40. Install the valve mount weldment on the top plate to the left of the motor. Secure with four 3/8" NC x 1" hex bolts and 3/8" lock washers.
41. Install grease fittings as follows:
 - i. Install two 1/4" UNF straight thread grease fittings (PN 02-0097) into the top cage plate.
 - ii. Install a 1/4" UNF straight thread grease fitting (PN 02-0097) in the top end of each gear shaft, located on the the top side of the tong (5 locations total).
 - iii. Install a 1/4" UNF straight thread grease fitting (PN 02-0097) in the end of the door pivot shaft.

I. DAILY INSPECTION & MAINTENANCE CHECKLIST (POWER TONG)

Farr recommends that the following inspection and maintenance procedures be performed before each use, and at least once per day when the tong is in steady use, in the order in which they are listed.

1. Rotate cage plate/rotary gear until the opening in the rotary gear faces towards the rear of the tong.



DO NOT PERFORM ANY FURTHER ACTIONS OR MAINTENANCE WHILE THE TONG IS CONNECTED TO ANY HYDRAULIC POWER SUPPLY. FARR RECOMMENDS THAT ALL HYDRAULIC LINES ARE FULLY DISCONNECTED, AND RESIDUAL HYDRAULIC PRESSURE IS BLED OFF. ENSURE ADEQUATE CONTAINMENT IS IN PLACE TO PREVENT ENVIRONMENTAL CONTAMINATION FROM RESIDUAL HYDRAULIC FLUID.

DEPRESSURIZE HYDRAULIC SYSTEM IN PREPARATION FOR MAINTENANCE:

2.
- 1) Rotate the tong to the "open throat" position. Ensure tong and backup doors (if equipped) are closed. Fully extend the lift cylinder
 - 2) De-energize the power unit.
 - 3) Repeatedly actuate the tong motor control valve lever **IN BOTH DIRECTIONS** to dissipate any residual pressure in the valve and motor.
 - 4) Remove the hydraulic SUPPLY line from the equipment.
 - 5) Repeatedly actuate the remaining control valve levers **IN BOTH DIRECTIONS** to dissipate any residual pressure in the remainder of the hydraulic control system.
 - 7) Disconnect the hydraulic RETURN line from the equipment.
 - 8) Disconnect remaining hoses such as case drains, or lines connected to the turns counter.



HYDRAULIC PRESSURES AS HIGH AS OPERATING PRESSURE MAY REMAIN TRAPPED IN SMALL AREAS OF THE EQUIPMENT. ENSURE ALL MAINTENANCE IS CARRIED OUT BY A QUALIFIED SERVICE TECHNICIAN, AND THAT ADEQUATE PERSONAL PROTECTIVE EQUIPMENT IS USED TO GUARD AGAINST PRESSURE INJURIES

3. Perform an initial wash of the tong in order to remove the majority of dirt and grease build-up. Ensure adequate containment is in place to prevent environmental contamination from residual hydraulic fluid and dirty grease.
4. Remove the access panel on the side of the tong directly adjacent to the shifter mechanism.
5. Use a flashlight to perform a visual inspection of the gear train through the access panel and the opening of the rotary gear. If gear damage or chips of metal are seen, the tong should be removed from service and overhauled to avoid further damage. Replace access panel when inspection is complete.
6. Perform a visual inspection of all fasteners and protruding body pieces (example: hydraulic valve mounts, inlet & outlet line supports, tong legs, shifter handle pivot lugs). Tighten or replace loose or missing fasteners. Farr recommends that damaged or missing body parts be repaired or replaced as soon as possible.
7. Inspect the jaws and dies. Inspect the jaw roller pins for signs of damage - replace pins if necessary. If the pins are welded in place, replace the entire jaw assembly. Ensure dies are secure in the jaw - replace worn dies if necessary. Ensure that the jaw rollers rotate freely. Check to ensure the size of the loaded jaws match the size of casing or pipe you are running.
8. Perform a visual inspection of all lifting points - if visible damage is seen, including cracks, broken lugs, distorted metal, etc. replace damaged part(s) before placing tong in service. Also inspect all chains, master links, and turnbuckles - again, if any damage is noted replace the damaged part(s) before placing the tong in service.
9. Inspect tong for signs of premature wear, or moving parts that are rubbing (bare metal where there used to be paint is a good indication of wear).
10. Inspect backing pin(s). If cracked, broken, or bent it (they) must be replaced.
11. Inspect top and bottom brake band linings - replace if necessary. Unequal wear of the brake bands indicates that the brake band tension is not evenly adjusted. Refer to the maintenance section of the manual for instructions on properly adjusting brake bands.
12. Perform a visual inspection of all hydraulic lines. Replace flexible lines if they appear to be cracked, fatigued, or have visible signs of wear from contact with a rigid object.
13. Perform a visual inspection of all hydraulic lines. Replace flexible lines if they appear to be cracked, fatigued, or have visible signs of wear from contact with a rigid object.

- 14. Perform a complete greasing of the tong - refer to Maintenance section of the technical manual
- 15. Ensure main supply and return connections to the tong are fully made up. Re-connect the remainder of the hydraulic lines, and, if applicable, the electrical line to the turns counter.



FAILURE TO ENSURE THAT THE SELF-SEALING SUPPLY AND RETURN LINES ARE FULLY MADE UP MAY RESULT IN CATASTROPHIC EQUIPMENT FAILURE.

If using a stand-alone power unit, start it now - refer to the power unit technical manual for startup procedures. Listen to power unit for a moment to see if there are any unusual mechanical sounds (rubbing, grinding, excessive pump noise). If using a diesel unit, allow sufficient time for the engine to reach operating temperature before increasing engine RPM. Once engine is warm, gradually increase engine RPM until operating speed is reached.

- 16. Ensure that supply pressure is at or above the tong's specified operating pressure, and that the return pressure is less than 350 psi.
- 17. Perform a visual inspection of pressurized hydraulic lines. Document and correct any hydraulic fluid leaks.
- 18. Perform a full functional test of the tong. Report and correct any hydraulic leaks from the hydraulic valve bank, or from any hydraulic cylinders that are used.
- 19. Perform a visual inspection of the load cell. If using a tension load cell, replace any cracked, broken, or distorted components including links and chains. If using a compression load cell, replace any component that has been crushed or otherwise distorted through compression.
- 20. If applicable, inspect the load cell anchor pins (tension load cell only). Replace the anchor pins if cracking or metal distortion is seen.
- 21. If applicable, the weld securing the single load cell anchor to the bridge bar main plate must be inspected (compression load cell only). If the integrity of the weld has been compromised, the tong must be removed from service until the weld is repaired. The load cell beam will need to be disconnected and removed so the weld is visible. Before re-installing the beam, liberally grease the anchor pin before reinserting into the load cell beam.
- 22. Test safety door feature (if equipped). Open the tong door(s), and attempt to rotate the cage plate at low speed (low gear) in both directions (makeup and breakout). If cage plate begins rotating, the safety door mechanism is not functional, and the tong must be removed from service until the safety door mechanism can be repaired. If the safety door is operating correctly, cage plate rotation will not be inhibited once the door is closed and latched.



NEVER OPERATE YOUR EQUIPMENT WITH A BYPASSED OR MALFUNCTIONING SAFETY DOOR

- 23. While rotating the cage plate, ensure that the jaws properly cam. If the jaws do not cam properly, the brake bands need to be tightened. Incrementally adjust both the top and bottom brake bands EQUALLY until proper cam action is achieved.

J. MONTHLY MAINTENANCE CHECKLIST - POWER TONG

The following maintenance checklist is intended as a guideline rather than a definitive maintenance schedule. Your equipment may require more, or less, maintenance depending upon the frequency of use, the percentage of maximum torque that your equipment is routinely subjected to, and the field conditions under which your equipment operates. Farr recommends that the following inspection and maintenance procedures be performed monthly, or in conjunction with your maintenance foreman's experience and best estimate of when your equipment is due for this maintenance.

1. Rotate cage plate/rotary gear until the opening in the rotary gear faces towards the rear of the tong.



DO NOT PERFORM ANY FURTHER ACTIONS OR MAINTENANCE WHILE THE TONG IS CONNECTED TO ANY HYDRAULIC POWER SUPPLY. FARR RECOMMENDS THAT ALL HYDRAULIC LINES ARE FULLY DISCONNECTED, AND RESIDUAL HYDRAULIC PRESSURE IS BLED OFF. ENSURE ADEQUATE CONTAINMENT IS IN PLACE TO PREVENT ENVIRONMENTAL CONTAMINATION FROM RESIDUAL HYDRAULIC FLUID.

DEPRESSURIZE HYDRAULIC SYSTEM IN PREPARATION FOR MAINTENANCE:

- 1) Rotate the tong to the "open throat" position. Ensure tong and backup doors (if equipped) are closed. Fully extend the lift cylinder
- 2) De-energize the power unit.
- 3) Repeatedly actuate the tong motor control valve lever **IN BOTH DIRECTIONS** to dissipate any residual pressure in the valve and motor.
- 4) Remove the hydraulic **SUPPLY** line from the equipment.
- 5) Repeatedly actuate the remaining control valve levers **IN BOTH DIRECTIONS** to dissipate any residual pressure in the remainder of the hydraulic control system.
- 7) Disconnect the hydraulic **RETURN** line from the equipment.
- 8) Disconnect remaining hoses such as case drains, or lines connected to the turns counter.

2.



HYDRAULIC PRESSURES AS HIGH AS OPERATING PRESSURE MAY REMAIN TRAPPED IN SMALL AREAS OF THE EQUIPMENT. ENSURE ALL MAINTENANCE IS CARRIED OUT BY A QUALIFIED SERVICE TECHNICIAN, AND THAT ADEQUATE PERSONAL PROTECTIVE EQUIPMENT IS USED TO GUARD AGAINST PRESSURE INJURIES

3. Clean the exterior of the tool thoroughly, using either water (if using a pressure washer ensure a low-pressure wash wand is used), or an appropriate solvent-based grease-cutting cleaner such as Varsol. Ensure adequate containment is in place to prevent environmental contamination from residual hydraulic fluid, dirty grease, and cleaning agents.
4. Remove the access panel on the side of the tong directly adjacent to the shifter mechanism.
5. Clean the interior of the tong thoroughly, using either water (do not use a pressure washer), or an appropriate solvent-based grease-cutting cleaner such as Varsol. Ensure adequate containment is in place to prevent environmental contamination from residual hydraulic fluid, dirty grease, and cleaning agents. Make a note if any metal shavings or metal pieces are flushed out of the gear train cavity - if shavings or metal pieces are seen the tong must be overhauled before it is returned to service.
6. Inspect all fasteners and fastener safety wires (if equipped). Replace any missing fasteners - use Grade 8 bolts only unless otherwise specified. Re-torque all external fasteners to SAE specifications.
7. Repair or replace any damaged or missing external body parts, such as torque gauge mounts, hydraulic supports, safety door protectors, etc.
8. Perform a visual inspection of all fasteners and protruding body pieces (example: hydraulic valve mounts, inlet & outlet line supports, tong legs, shifter handle pivot lugs). Tighten or replace loose or missing fasteners. Farr recommends that damaged or missing body parts be repaired or replaced as soon as possible.
9. Inspect tong for signs of premature wear, or moving parts that are rubbing (bare metal where there used to be paint is a good indication of wear).
10. Inspect all paint - locations in which the paint has been damaged must be repaired prior to the tong being returned to service. Prepare areas to be painted to ensure they are free of grease, dirt, or solvent. Touch up using a solvent-based acrylic paint - "McCoy Grey" is paint color number RAL7015 (contact Farr sales for paint number for custom paint applications). Allow sufficient time for paint to dry before proceeding.
11. Inspect all external welds. Any weld that is cracked or separating must be repaired and repainted before returning the tong to service.

12.

Perform a visual inspection of all lifting points - if visible damage is seen, including cracks, broken lugs, distorted metal, etc. replace damaged part(s) before placing tong in service. Also inspect all chains, master links, and turnbuckles - again, if any damage is noted replace the damaged part(s) before placing the tong in service. Refer to Section 2A of the technical manual (Sling/Load Bearing Device Safety) for information on recommended testing and recertification. Please note that turnbuckles with part number 101-3086 (short turnbuckles) use a high-strength pin which must be supplied by Farr.



“SHORT” TURNBUCKLES HAVING PART NUMBER 101-3086 EMPLOY HIGH-STRENGTH PINS WHICH MUST BE SUPPLIED BY FARR.

13.

Rotate the gear train by hand, and use a flashlight to perform a visual inspection of the gear train through the access panel and the opening of the rotary gear while the gear train is being rotated. If gear damage or chips of metal are seen, the tong should be removed from service and overhauled to avoid further damage. Replace access panel when inspection is complete.

14.

Inspect all jaws and dies in use for the maintenance interval. Inspect the jaw roller pins for signs of damage - replace pins if necessary. If the pins are welded in place, remove and quarantine the jaw until the weld is repaired. Ensure dies are secure in the jaw - replace worn dies if necessary. Ensure that the jaw rollers rotate freely.

15.

Inspect backing pin(s). If cracked, broken, or bent it (they) must be replaced.

16.

Inspect top and bottom brake band linings - replace if necessary. Unequal wear of the brake bands indicates that the brake band tension is not evenly adjusted. Refer to the maintenance section of the manual for instructions on properly adjusting brake bands.

17.

Inspect door springs. Ensure the springs retain sufficient strength to be able to assist the opening of the door, and to keep the door open. The springs should also help to “snap” the door shut.

18.

Inspect backup springs (if applicable). The rear extension springs should be equally extended, and the front leg springs should be equally compressed. Ensure that neither of the rear backup springs have been over-extended and lack sufficient tension to adequately support the backup. Ensure that neither of the front leg springs have been over-compressed, and still retain enough spring strength to support the front of the backup.

19.

Extend all hydraulic cylinders, and inspect cylinder rods for signs of mechanical damage, flaking, or rust. Farr recommends that damaged cylinders be replaced prior to storage.

20.

Perform a visual inspection of all hydraulic lines. Replace flexible lines if they appear to be cracked, fatigued, or have visible signs of wear from contact with a rigid object. If your tong is equipped with rigid hydraulic lines, replace any line that is dented or appears to be stressed or cracked.

21.

Generously fill the gear train housing with grease through the access panel, and also through the opening in the rotary gear. Perform a full lubrication - refer to Maintenance section of manual to determine lubrication points.

22.

Ensure main supply and return connections to the tong are fully made up. Re-connect the remainder of the hydraulic lines, and, if applicable, the electrical line to the turns counter.



FAILURE TO ENSURE THAT THE SELF-SEALING SUPPLY AND RETURN LINES ARE FULLY MADE UP MAY RESULT IN CATASTROPHIC EQUIPMENT FAILURE.

If using a stand-alone power unit, start it now - refer to the power unit technical manual for startup procedures. Listen to power unit for a moment to see if there are any unusual mechanical sounds (rubbing, grinding, excessive pump noise). If using a diesel unit, allow sufficient time for the engine to reach operating temperature before increasing engine RPM. Once engine is warm, gradually increase engine RPM until operating speed is reached.

23.

Ensure that supply pressure is at or above the tong’s specified operating pressure, and that the return pressure is less than 350 psi.

24.

Perform a visual inspection of pressurized hydraulic lines. If any hydraulic fittings or hoses are leaking they must be repaired or replaced before proceeding.

25.

Rotate tong for one minute, stop, and reverse the direction of rotation for another minute, ending with the opening of the rotary gear facing the gear train. De-energize the power unit, and perform another generous lubrication of the gear train, including the gear housing.

26.

Energize power unit. Rotate tong for one minute, stop, and reverse the direction of rotation for another minute, ending with the opening of the rotary gear facing the gear train.

27.

De-energize the power unit, and perform a third generous lubrication of the gear train, including the gear housing.

28. Re-energize power unit and extend all hydraulic cylinders. Inspect cylinder rods for signs of mechanical damage, flaking, or rust. Farr recommends that damaged cylinders be replaced.
29. Rotate tong in low gear for 5 minutes while monitoring pressurized seals and hydraulic lines. If a seal, line, or fitting begins to leak while tong is rotating, it must be replaced before the equipment is returned to service.
30. Rotate tong in high gear for 5 minutes while monitoring temperature of top and bottom bearing caps. If the bearing caps are hot to the touch (higher than approximately 50°C) replace the applicable bearings. Likewise if the tong is making unusual noises check for damaged bearings (see Maintenance Manual for all bearing locations).
31. Install load cell. If using a tension load cell, perform a visual inspection and replace any cracked, broken, or distorted components including links and chains. If using a compression load cell, replace any component that has been crushed or otherwise distorted through compression.
32. If applicable, inspect the load cell anchor pins (tension load cell only). Replace the anchor pins if cracking or metal distortion is seen.
33. If applicable, the weld securing the single load cell anchor to the bridge bar main plate must be inspected (compression load cell only). If the integrity of the weld has been compromised, the tong must be removed from service until the weld is repaired. The load cell beam will need to be disconnected and removed so the weld is visible. Before re-installing the beam, liberally grease the anchor pin before reinserting into the load cell beam.
34. Inspect load cell for damage or signs of stress. Check oil level in load cell and fill if necessary (refer to technical manual Section 7 or Section 8).
35. While rotating the cage plate, ensure that the jaws properly cam. If the jaws do not cam properly, the brake bands need to be tightened. Incrementally adjust both the top and bottom brake bands EQUALLY until proper cam action is achieved. Refer to the maintenance section of the manual for instructions on properly adjusting brake bands.
36. Perform a full functional test of the tong including, if applicable, backup components, lift cylinder, and float frame components. Report and correct any hydraulic leaks from the hydraulic valve bank, or from any hydraulic cylinders that are used.
37. Test safety door feature (if equipped). Begin rotating the tong at low speed, and open the tong door(s). If rotation does not immediately stop, this is an indication that the safety door mechanism is not operating correctly and the tong must be removed from service until the mechanism is repaired. Repeat the test while operating the tong in the opposite direction. If the safety door is operating correctly, cage plate rotation will not be inhibited once the door is closed and latched.



NEVER OPERATE YOUR EQUIPMENT WITH A BYPASSED OR MALFUNCTIONING SAFETY DOOR

38. Farr recommends that an anti-corrosive agent such as Tectyl® 506 be applied to all external unpainted surfaces (and chain slings) EXCEPT cylinder rods, jaw rollers, and rotary gear camming surfaces. Refer to manufacturer data sheets for proper application and safety information.

Once all of the above maintenance checklist items have been satisfactorily completed the tool may be returned to service.

K. DAILY INSPECTION & MAINTENANCE CHECKLIST (BACKUPS)

Farr Canada recommends that the following inspection and maintenance procedures be performed before each use, and at least once per day when the backup is in steady use, in the order in which they are listed.

Do not perform any maintenance while the tong and backup assembly is connected to any hydraulic power supply. Farr Canada recommends that all hydraulic lines are fully disconnected, and residual hydraulic pressure is bled off. Ensure adequate containment is in place to prevent environmental contamination from residual hydraulic fluid.

ALL UNITS

- 1. Perform an initial wash of the backup in order to remove the majority of dirt and grease build-up.
- 2. Perform an external inspection. Check to ensure there are no loose or missing fasteners - replace if necessary.
- 3. Check to see if backup is parallel to the tong - if the backup is resting at an angle, one of the front leg springs is likely broken or fatigued to the point it must be replaced.

WEDGE BACKUP ONLY

- 4. Remove access cover from top plate. Perform a visual inspection of the interior of the backup - use a flashlight if necessary. Premature wear where there are moving parts (bare metal where there used to be paint, and metal shavings in the grease are good indicators) may show where a component needs to be adjusted, or if necessary, replaced.
- 5. Inspect latch mechanism to ensure the door latch plate completely engages the door. Adjust or replace if necessary.
- 6. Grease UC-300 slider pads, ram guides, door cylinder pivots, and door pivots.

CLINCHER BACKUP ONLY

- 4. Use a flashlight to perform a visual inspection of the interior of the backup - remove one side panel if necessary. Premature wear where there are moving parts (bare metal where there used to be paint, and metal shavings in the grease are good indicators) may show where a component needs to be adjusted, or if necessary replaced. Replace any removed panels when inspection is complete.
- 5. Grease clincher cylinder guides using the grease fittings on the top body plate.
- 6. Ensure the splines on the clincher cylinder faces, and on the rear of the die are clean and free of debris before inserting clincher die. If die are already installed, ensure fasteners in the die retainers are tightly secured.
- 7. Inspect rear spring hanger assembly. Ensure all eye bolts, shackles, and cotter pins are in place and in good condition.
- 8. Inspect clincher cylinders for hydraulic fluid leaks once the system pressure has been restored.

FARR-STYLE BACKUP ONLY

- 4. Inspect cam ring gear for broken teeth.
- 5. Lubricate the cam follower array.
- 6. Inspect the jaws and dies. Inspect the jaw roller pins for signs of damage - replace pins if necessary. If the pins are welded in place, replace the entire jaw assembly. Ensure dies are secure in the jaw - replace worn dies if necessary. Ensure that the jaw rollers rotate freely. Check to ensure the size of the loaded jaws match the size of casing or pipe you are running.
- 7. Inspect front and rear cam cylinder supports. Repair or replace any parts that are broken, cracked, or bent.
- 8. Inspect rear spring hanger assembly. Ensure all eye bolts, shackles, and cotter pins are in place and in good condition.
- 9. Open the backup door and inspect the condition of the latch. Repair or replace damaged latch components. If latch appears to be in good condition, close the door, then tug firmly on it to ensure the door remains latched.

ALL UNITS (AFTER STARTING POWER UNIT)

- 10. Perform a visual inspection of pressurized hydraulic lines - document and correct any hydraulic fluid leaks.
- 11. Perform a full functional test of the backup. Document and correct hydraulic leaks from the hydraulic valve bank, or from any hydraulic cylinders that are in use on the backup.

L. DAILY INSPECTION & MAINTENANCE CHECKLIST (POWER UNIT)

Farr recommends that the following inspections and maintenance procedures be performed before each use, and at least once per day when the equipment is in steady use, in the sequence in which they are listed. Rigorous inspection and maintenance, especially lubrication, is essential in order to ensure that your equipment always meets specifications, and to prevent catastrophic failures that can severely damage your equipment and cause worker injury.

If using a stand-alone power unit, perform the following inspection and maintenance procedures before each use, and at least once per day when the power unit is in steady use:

Do not perform any maintenance while the power unit is energized (electric) or if the engine is running (diesel). Ensure the electrical supply is locked out, or, if using a diesel power supply, ensure that the engine is locked out or the starting mechanism otherwise disabled.

DIESEL ONLY

1. Check engine oil levels - add if necessary
2. Check diesel fuel tank - fill if necessary.
3. Visually inspect all fan belts.
4. Activate mechanical shut-off device - ensure that shut-off switch on engine is engaging when manual shut-off switch is actuated.

ELECTRIC ONLY

1. Visually inspect all electrical lines and visible connections. If your unit is NOT explosion proof, open the electrical enclosure and VISUALLY inspect contacts and connections for signs of corrosion or arcing. Do not open explosion-proof enclosures.



NEVER PLACE HANDS INSIDE AN ELECTRICAL ENCLOSURE UNLESS YOU HAVE CONFIRMED THAT THE POWER HAS BEEN DISCONNECTED AND LOCKED OUT

2. Visually inspect main electrical line between main power source and power unit.

ALL UNITS

5. Perform a visual inspection of all parts. Check to ensure there are no loose or missing fasteners.
6. Check hydraulic fluid level - ensure cold level is approximately half-way up the sight glass on the hydraulic fluid reservoir.
7. Perform a visual inspection to ensure there are no hydraulic fluid leaks - correct if necessary.
8. Check that the main supply and return lines on the hydraulic fluid reservoir are both fully open.
9. Apply grease to any grease fittings that your power unit may have. Apply grease to each fitting until grease is visibly displaced from bearing, or as recommended by your power unit manual.
10. Ensure supply and return connections at the power unit and at the equipment in use are fully made up.



FAILURE TO ENSURE THAT THE SELF-SEALING SUPPLY AND RETURN LINES ARE FULLY MADE UP MAY RESULT IN CATASTROPHIC EQUIPMENT FAILURE.

11. Check hydraulic fluid filter back pressure (must be done while fluid is circulating). If needle on indicator gauge is in the red zone, the filter should be changed the next time the unit is shut down

M. TUBULAR CONNECTION EQUIPMENT DE-COMMISSIONING PROCEDURE

Perform the following decommissioning procedures when removing tubular connection equipment from service, with the intent of short to long-term storage. These procedures are essential for ensuring proper protection of the equipment from environmental attack, and to aid in the quick turnaround when returning the equipment to service.

Store all o-rings, seals, packings, gaskets, etc. in strong moisture proof, airtight containers. Ensure that these items are not crushed, nicked, or otherwise damaged.

Do not perform any further actions or maintenance while the tong is connected to any hydraulic power supply. Farr recommends that all hydraulic lines are fully disconnected, and residual hydraulic pressure is bled off. Ensure adequate containment is in place to prevent environmental contamination from residual hydraulic fluid.

DEPRESSURIZATION PROCEDURE IN PREPARATION FOR STORAGE:

- 1) Rotate the tong so that the opening in the rotary gear faces the gear train (towards the rear of the tong). Ensure tong and backup doors (if equipped) are closed. Fully extend the lift cylinder (if equipped). If mounted in a frame, retract the float cylinders (if equipped).
- 2) De-energize the power unit.
- 3) Repeatedly actuate the tong motor control valve lever IN BOTH DIRECTIONS to dissipate any residual pressure in the valve and motor.
- 4) Remove the hydraulic SUPPLY line from the equipment.
- 5) Repeatedly actuate the remaining control valve levers IN BOTH DIRECTIONS to dissipate any residual pressure in the remainder of the hydraulic control system.
- 7) Disconnect the hydraulic RETURN line from the equipment.
- 8) Disconnect remaining hoses such as case drains, or lines connected to the turns counter.



HYDRAULIC PRESSURES AS HIGH AS OPERATING PRESSURE MAY REMAIN TRAPPED IN SMALL AREAS OF THE EQUIPMENT. ENSURE ALL MAINTENANCE IS CARRIED OUT BY A QUALIFIED SERVICE TECHNICIAN, AND THAT ADEQUATE PERSONAL PROTECTIVE EQUIPMENT IS USED TO GUARD AGAINST PRESSURE-INDUCED INJURIES

1. Perform an initial wash of the tool in order to remove the majority of dirt and grease build-up. Ensure adequate containment is in place to prevent environmental contamination from residual hydraulic fluid and dirty grease.
2. Remove the access panel on the side of the tong directly adjacent to the shifter mechanism.
Clean the interior of the tong thoroughly, using either water (do not use a pressure washer), or an appropriate solvent-based grease-cutting cleaner such as Varsol. Ensure adequate containment is in place to prevent environmental contamination from residual hydraulic fluid, dirty grease, and cleaning agents. Make a note if any metal shavings or metal pieces are flushed out of the gear train cavity - if shavings or metal pieces are seen the tong must be overhauled before it is returned to service.
3. Clean the exterior of the tool thoroughly, using either water (do not use a pressure washer), or an appropriate solvent-based grease-cutting cleaner such as Varsol. Ensure adequate containment is in place to prevent environmental contamination from residual hydraulic fluid, dirty grease, and cleaning agents.
4. Inspect all fasteners and fastener safety wires. Replace any missing fasteners - use Grade 8 bolts only. Re-torque all external fasteners to SAE specifications.
5. Inspect backing pin(s). If cracked, broken, or bent it (they) must be replaced.
6. Repair or replace any damaged or missing external body parts, such as torque gauge mounts, hydraulic supports, safety door protectors, etc.
7. Inspect all paint - locations in which the paint has been damaged must be repaired prior to storage. Prepare areas to be painted to ensure they are free of grease, dirt, or solvent. Touch up using a solvent-based acrylic paint - "McCoy Grey" is paint number RAL7015. Allow sufficient time for paint to dry before proceeding.
8. Perform a liberal lubrication of the equipment - refer to Maintenance section of manual to determine lubrication points. Generously fill the gear train housing with grease through the access panel, and also through the opening in the rotary gear.
9. Connect the equipment to a hydraulic power unit. Ensure all lines are fully made up to prevent equipment damage from excessive back pressure. Do not neglect to connect the motor drain.
10. Energize power unit.
11. Rotate tong for one minute, stop, and reverse the direction of rotation for another minute, ending with the opening of the rotary gear facing the gear train. De-energize the power unit, and perform another generous lubrication of the gear train, including the gear housing.
12. Energize power unit. Rotate tong for one minute, stop, and reverse the direction of rotation for another minute, ending with the opening of the rotary gear facing the gear train.
13.

14. De-energize the power unit, and perform a third generous lubrication of the gear train, including the gear housing.
15. Energize power unit, and rotate the tong for a final time, one minute in one direction, stop, and reverse the direction of rotation for another minute, this time ending with the rotary gear in the "open throat" position.
16. Extend all hydraulic cylinders, and inspect cylinder rods for signs of mechanical damage, flaking, or rust. Farr recommends that damaged cylinders be replaced prior to storage.

17. If you are using a frame-mounted tool, the tong must be lowered onto the backup in order to remove the risk of sudden and catastrophic movement when pressure is removed from the float cylinders. Cover the top of the backup with protective cloth to protect the paint on the backup. Place two wooden beams across the top of the tong, ensuring that the beams have a minimum size of 4" x 4" x the width of the tong. Cover the tops of the wooden beams with more protective cloth to prevent paint damage to the tong. When lowering the tong onto the beams, ensure that the beams come into flat contact with the bottom of the tong, away from bearing caps, brake bands, or other protrusions on the bottom of the tong. Ensure that the tong hanger chains are loose, but not dangling into contact with the hangers or top plate of the tong.

DEPRESSURIZATION PROCEDURE FOR STORAGE:

- 1) Rotate the tong to the "open throat" position.
- 2) Exercise each hydraulic cylinder several times - open the tong and backup doors (if equipped), retract and extend the remote backing pin ramp (if equipped), retract and extend the float cylinders. Leave all cylinders except for the door cylinders in their fully retracted position. The general idea is to have as little of the chrome cylinder rods exposed as possible.
- 3) De-energize the power unit.
- 4) Repeatedly actuate the tong motor control valve lever IN BOTH DIRECTIONS to dissipate any residual pressure in the valve and motor.
- 5) Remove the hydraulic SUPPLY line from the equipment.
- 6) Repeatedly actuate the remaining control valve levers IN BOTH DIRECTIONS to dissipate any residual pressure in the remainder of the hydraulic control system.
- 7) Connect a low-pressure air supply line (10 PSI or less) to the hydraulic supply line, and force a small amount of the remaining hydraulic fluid from the valve assembly - this will allow for thermal expansion of the hydraulic fluid if the equipment is stored or transported in high ambient temperatures. Failure to do this may result in damaged or destroyed seals in the equipment.
- 8) Disconnect the hydraulic RETURN line from the equipment.
- 9) Disconnect remaining hoses such as case drains, or lines connected to the turns counter.

18. If any hydraulic fittings or hoses are leaking they must be repaired or replaced before proceeding.
19. Wipe all excess grease from outside of equipment. Replace the access door panel. Use a solvent-based cleaner on rags to wipe all external surfaces to remove residual grease or hydraulic fluid. Once the outside surfaces have been de-greased, wipe all external surfaces with clean water to remove residual solvent.
20. Farr recommends that chain slings be removed and stored separately. Rigid slings and other rigid suspension devices may remain in place.
21. Apply grease or heavy oil to all exposed cylinder rods.
22. Farr recommends that an anti-corrosive agent such as Tectyl® 506 be applied to all external surfaces EXCEPT cylinder rods (including chain slings). Refer to manufacturer data sheets for proper application and safety information.



DO NOT ALLOW ANTI-CORROSIVE AGENTS TO CONTACT CYLINDER RODS. CYLINDER ROD DAMAGE WILL OCCUR.

23. Allow the anti-corrosive coating ample time to dry - refer to manufacturer data sheets for drying times at room temperature.
24. Wrap entire assembly in 100 gauge (1 mil) corrosion-inhibiting wrap, at least 3 layers thick. Attempt to ensure that the tool is well-sealed within the wrapping, including the bottom.

If possible, store in a sealed, climate controlled environment. If isolated storage is not available, Farr recommends storing your wrapped equipment in a secure, out-of-the-way location, using silica gel desiccant to reduce the humidity within the wrapping. As a guideline, use 125 g. of desiccant for each cubic metre of space, or 3.5 g. per cubic foot.

CALCULATION OF REQUIRED DESICCANT

- 1) Calculate the trapped air volume by measuring the outside dimensions of the tool to be stored, and treat that as the volume to be stored. For example, the external dimensions of a KT20000 20" power tong are 80.25" x 50.5" x 28", which calculates to an approximate volume of 113500 in³, or 66 ft³ (1.87 m³).
- 2) Multiply the calculated air volume, in cubic feet, by the recommended amount of desiccant per cubic foot. Carrying forth the example used in the previous step, the required desiccant charge would be 3.5 g. x 66 ft³, equaling 231 g. Several manufacturers offer silica gel desiccant in packaged quantities of 125 grams per bag, so two packages of desiccant would be required. Please keep in mind that this is a guideline only - more or less desiccant may be required in extreme environmental conditions.

For best corrosion resistance the equipment should be removed from storage and exercised on a regular basis, depending on the storage environment. Farr recommends that for equipment stored in a salt-water maritime or exposed dusty environment, repeat steps 9 through 24 monthly. For equipment stored in isolated storage in a non-maritime environment, repeat steps 9 through 24 quarterly. Replace desiccant packs at this time - depleted desiccant packs may be treated as regular dunnage.

N. TUBULAR CONNECTION EQUIPMENT RE-COMMISSIONING PROCEDURE

Perform the following recommissioning procedures when removing tubular connection equipment from short or long-term storage back into regular service. These procedures are essential for ensuring proper equipment preparation and operation. The following procedures also assume that the decommissioning and storage procedures recommended by Farr have been strictly observed.

1. Remove all protective plastic wrapping. If there are desiccant packs with the assembly, they may be disposed of with the regular garbage.
2. Remove the access panel on the side of the tong directly adjacent to the shifter mechanism.
3. Wipe excess grease or heavy oil from exposed cylinder rods.
If applicable, re-connect chain sling to lifting lugs. Perform a visual inspection of all lifting points - if visible damage is seen, including cracks, broken lugs, distorted metal, etc. replace damaged part(s) before placing tong in service. Also inspect all chains, master links, and turnbuckles - again, if any damage is noted replace the damaged part(s) before placing the tong in service. If your company requires yearly certification of lifting equipment, ensure that the most recent test date falls within the past year. Perform recertification if necessary.
4. Perform a liberal lubrication of the equipment - refer to Maintenance section of manual to determine lubrication points. Generously fill the gear train housing with grease through the access panel, and also through the opening in the rotary gear.
5. Connect the equipment to a hydraulic power unit. Ensure all lines are fully made up to prevent equipment damage from excessive back pressure. Do not neglect to connect the motor drain.



FAILURE TO ENSURE THAT THE SELF-SEALING SUPPLY AND RETURN LINES ARE FULLY MADE UP MAY RESULT IN CATASTROPHIC EQUIPMENT FAILURE.

7. Energize power unit.
8. Ensure that supply pressure is at or above the tong's specified operating pressure, and that the return pressure is less than 350 psi.
9. Perform a thorough inspection of pressurized hydraulic lines and fittings. Any leaking hydraulic fluid lines or fittings must be replaced before the equipment is returned to service.
10. Perform a thorough inspection of all seals. Any seal that is leaking or "weeping" must be replaced before the equipment is returned to service.
11. Rotate tong in low gear for 5 minutes while monitoring pressurized seals and hydraulic lines. If a seal, line, or fitting begins to leak while tong is rotating, it must be replaced before the equipment is returned to service. Finish this step with the rotary gear opening facing the gear train. De-energize the power unit.
12. Inspect all flexible hydraulic lines for signs of wear, blistering, or any other signs of potential failure - replace if signs of potential failure are identified.
13. Inspect the gear train housing. If the amount of grease is inadequate, liberally grease the gear train through the access panel, and through the opening in the rotary gear.
Inspect top and bottom brake band linings - replace if necessary. Unequal wear of the brake bands indicates that the brake band tension is not evenly adjusted. Refer to the maintenance section of the manual for instructions on properly adjusting brake bands. Ensure that all grease is wiped from brake band linings and the parts of the cage plates that come into contact with the brake band linings
14. Re-install access panel. Install a set of pre-inspected jaws that are the correct size for the pipe or casing being run.
15. Install load cell. If using a tension load cell, perform a visual inspection and replace any cracked, broken, or distorted components including links and chains. If using a compression load cell, replace any component that has been crushed or otherwise distorted through compression.
16. If applicable, inspect the load cell anchor pins (tension load cell only). Replace the anchor pins if cracking or metal distortion is seen.
If applicable, the weld securing the single load cell anchor to the bridge bar main plate must be inspected (compression load cell only). If the integrity of the weld has been compromised, the tong must be removed from service until the weld is repaired. The load cell beam will need to be disconnected and removed so the weld is visible. Before re-installing the beam, liberally grease the anchor pin before reinserting into the load cell beam.
17. Re-energize power unit.

20. Perform a full functional test of the equipment including, if applicable, backup components and float frame components. Report and correct any hydraulic leaks from the hydraulic valve bank, or from any hydraulic cylinders that are used.
21. If using a frame-mounted tong and backup system, raise the tong off the beams that it is resting upon. Remove the beams and protective cloths - inspect the paint on top of the backup and the bottom of the tong to ensure it has not been damaged by the beam.
22. Test safety door feature (if equipped). Open the tong door(s), and attempt to rotate the cage plate at low speed (low gear) in both directions (makeup and breakout). If cage plate begins rotating, the safety door mechanism is not functional, and the tong must be removed from service until the safety door mechanism can be repaired. If the safety door is operating correctly, cage plate rotation will not be inhibited once the door is closed and latched.



NEVER OPERATE YOUR EQUIPMENT WITH A BYPASSED OR MALFUNCTIONING SAFETY DOOR

23. While rotating the cage plate, ensure that the jaws properly cam. If the jaws do not cam properly, the brake bands need to be tightened. Incrementally adjust both the top and bottom brake bands EQUALLY until proper cam action is achieved.
24. When all of the previous steps are completed, you may return your re-commissioned equipment to service.



***This page intentionally
left blank***

Adequate maintenance and proper fluid selection is essential for minimizing hydraulic-related failures. All troubleshooting must be performed by a technician trained in hydraulic systems, and familiar with the equipment design, assembly and operation.

The following troubleshooting instructions are intended to be guidelines only. Any faults not solved through the use of this guide should be referred to our engineering department for their evaluation and recommendations.

A. TONG WILL NOT DEVELOP SUFFICIENT TORQUE

1. *Malfunctioning relief valve on tong hydraulic circuit.*
 - a. *POSSIBLE PROBLEM: Relief pressure set too low.*
SOLUTION: Increase setting. To check, block the oil line beyond the relief valve and determine pressure with a gauge.
 - b. *POSSIBLE PROBLEM: Relief valve is stuck.*
SOLUTION: Check for contamination of oil that may inhibit the way the valve actuates. Remove valve and clean, ensuring that the valve spring operates smoothly.
 - c. *POSSIBLE PROBLEM: Relief valve is leaking.*
SOLUTION: Check valve seat for scouring. Check oil seals. Check for particles stuck under the valve system.
2. *POSSIBLE PROBLEM: Directional valve is leaking.*
SOLUTION: Check directional valve. Neutral position should return fluid directly to the reservoir. Replace or repair valve to ensure correct operation.
3. *POSSIBLE PROBLEM: Power unit is malfunctioning.*
SOLUTION: Troubleshoot power unit (see user's manual for your particular unit).
4. *POSSIBLE PROBLEM: Poor hydraulic pressure at the tong despite adequate pressure at the power unit, or excessive back pressure in the return line.*
SOLUTION: Restrictions exist in line between power unit and tong. Inspect integrity of self-sealing couplings to ensure they are allowing full fluid flow. Check to ensure no other restrictions exist (contaminated catch screens or filters, for example).
5. *POSSIBLE PROBLEM: Fluid viscosity is not appropriate (too high or too low).*
SOLUTION: Ensure hydraulic fluid being used is the viscosity recommended by McCoy Drilling & Completions. Power unit pump may not prime if fluid is too heavy, and the hydraulic system will overheat if fluid is too light. Replace with proper viscosity fluid.
SOLUTION: Hydraulic fluid viscosity is affected by environmental conditions. Ensure the fluid being used is suitable for high or low temperatures. Replace with proper viscosity fluid for the operating conditions if necessary.
6. *POSSIBLE PROBLEM: Worn or damaged tong motor causing slippage.*
SOLUTION: Replace or repair worn or damaged motor.
7. *POSSIBLE PROBLEM: Damaged bearings or gears causing excessive drag.*
SOLUTION: Replace or repair worn or damaged gears or bearings.
8. *POSSIBLE PROBLEM: Jaws slipping on pipe.*
SOLUTION: Ensure jaw dies are not worn to the point that they cannot grip. Ensure the correct sized jaws are in use.
9. *POSSIBLE PROBLEM: Torque gauge is indicating incorrectly*
SOLUTION: Incorrect gauge is being used. Ensure gauge is the proper range, and has been properly calibrated for the arm length of the equipment in use.
SOLUTION: Gauge has been damaged. Check gauge operation and calibration on independent system.
10. *POSSIBLE PROBLEM: Load cell is measuring incorrectly.*
SOLUTION: Incorrect load cell is being used.
SOLUTION: Air is trapped in torque measuring circuit (load cell, hydraulic line, or gauge. Refer to torque measurement troubleshooting in Section 6 of this manual.
SOLUTION: Load cell has been damaged. Replace load cell, or return to McCoy for repair and re-calibration.

TONG WILL NOT DEVELOP SUFFICIENT TORQUE Cont'd:

11. *POSSIBLE PROBLEM: Incorrect motor speed selected.*
SOLUTION: Maximum torque can only be developed when motor is in the lowest speed. Ensure motor is in low speed.

12. *POSSIBLE PROBLEM: Incorrect tong gear selected.*
SOLUTION: Maximum torque can only be developed when tong is in low gear. Ensure tong is in low gear.



FARR CANADA CORP. GUARANTEES CALIBRATION OF A LOAD CELL/TORQUE GAUGE ASSEMBLY FOR A PERIOD OF ONE YEAR. FARR CANADA CORP. SUGGESTS THAT THE LOAD CELL/TORQUE GAUGE ASSEMBLY BE RETURNED TO THE FACTORY FOR RE-CALIBRATION ON A YEARLY BASIS.

B. FAILURE OF JAWS TO GRIP PIPE

1. *POSSIBLE PROBLEM: Dies have become too dull to provide adequate grip.
SOLUTION: Replace dies.*
2. *POSSIBLE PROBLEM: Incorrect jaws are being used.
SOLUTION: Double-check jaw size to ensure they are rated for the diameter of pipe or casing being run.*
3. *POSSIBLE PROBLEM: Incorrect dies are being used
SOLUTION: Ensure dies loaded in the jaws are appropriate for the type of pipe or casing being run.*
4. *POSSIBLE PROBLEM: Brake band(s) is (are) insufficiently adjusted, not allowing jaws to cam properly.
SOLUTION: Adjust brake bands to give proper resistance to cage plates.*
5. *POSSIBLE PROBLEM: Jaw roller broken or worn.
SOLUTION: Remove jaw assembly and inspect. Replace rollers that are visibly "flat-spotted" or otherwise damaged.*

C. TONG RUNNING TOO SLOWLY

1. **POSSIBLE PROBLEM:** Obstruction in tong hydraulic circuit preventing adequate flow.
SOLUTION: Inspect self-sealing couplings to ensure they are properly engaged.
SOLUTION: The main hydraulic lines (supply and discharge) to the tong are obstructed. Remove and clean if required.
2. **POSSIBLE PROBLEM:** Power unit is not producing adequate flow or pressure.
SOLUTION: Troubleshoot power unit (see user's manual for your particular unit).
3. **POSSIBLE PROBLEM:** Tong motor is excessively worn and is leaking hydraulic fluid past the vanes.
SOLUTION: Replace motor, or rebuild as per Section 7 of this manual.
4. **POSSIBLE PROBLEM:** Bearings in gear train and rotary section are excessively worn.
SOLUTION: Overhaul tong. See Section 3 of this manual for tong overhaul procedures.
5. **POSSIBLE PROBLEM:** Shifter has malfunctioned and the tong is not shifting to high gear.
SOLUTION: Inspect and repair shift mechanism as necessary.
6. **POSSIBLE PROBLEM:** Two-speed hydraulic motor (if equipped) is not set to correct speed.
SOLUTION: Check motor, and set to the correct speed if required.
7. **POSSIBLE PROBLEM:** Safety door system is not properly adjusted - hydraulic fluid leak past Deltrol valve.
SOLUTION: Check and adjust safety door system.
8. **POSSIBLE PROBLEM:** Hydraulic fluid viscosity too high.
SOLUTION: Ensure hydraulic fluid meets McCoy Drilling & Completions specifications.
SOLUTION: Ensure hydraulic fluid is appropriate for climatic conditions, especially during cold-weather operation..
9. **POSSIBLE PROBLEM:** By-pass valve not functioning.
SOLUTION: Check and repair.

D. GENERAL COMMENTS

The following factors generally contribute to poor hydraulic operation and premature wear of equipment:

- 1. Contaminated hydraulic fluid due to overuse, overheating, or inadequate fluid filtration.*
- 2. Unsuitable hydraulic fluid, especially in extreme climatic conditions.*
- 3. Defective packing or seals in components of the hydraulic system.*
- 4. Poor or incomplete hydraulic system training. Users must be fully qualified to operate the equipment, and have complete understanding of the hydraulic system.*

If your hydraulic troubleshooting procedures involve flow and pressure tests at the power unit, McCoy Completions & Drilling recommends construction of a test rig that can easily be connected to the main suction and discharge ports of the power unit.



***This page intentionally
left blank***

Parts & Assemblies

Model 80-2001-8 Shown



Model 80-2001-10 Shown

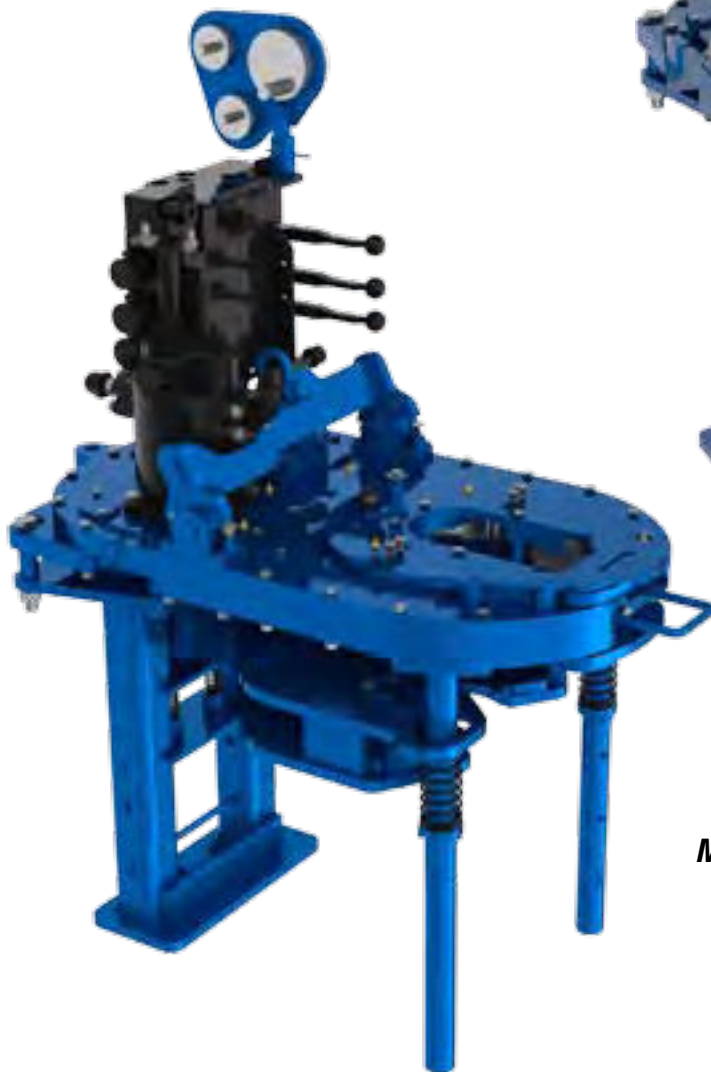

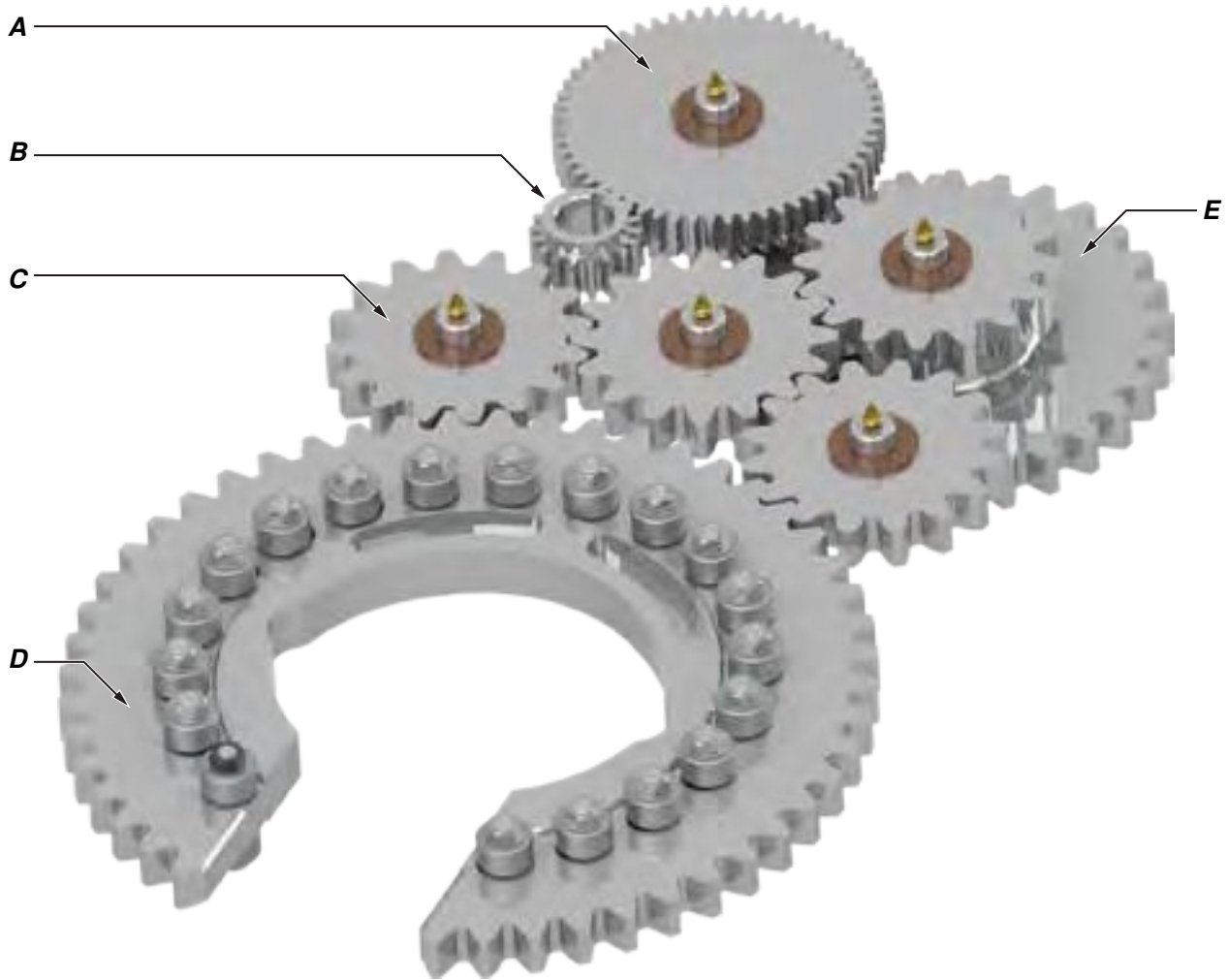

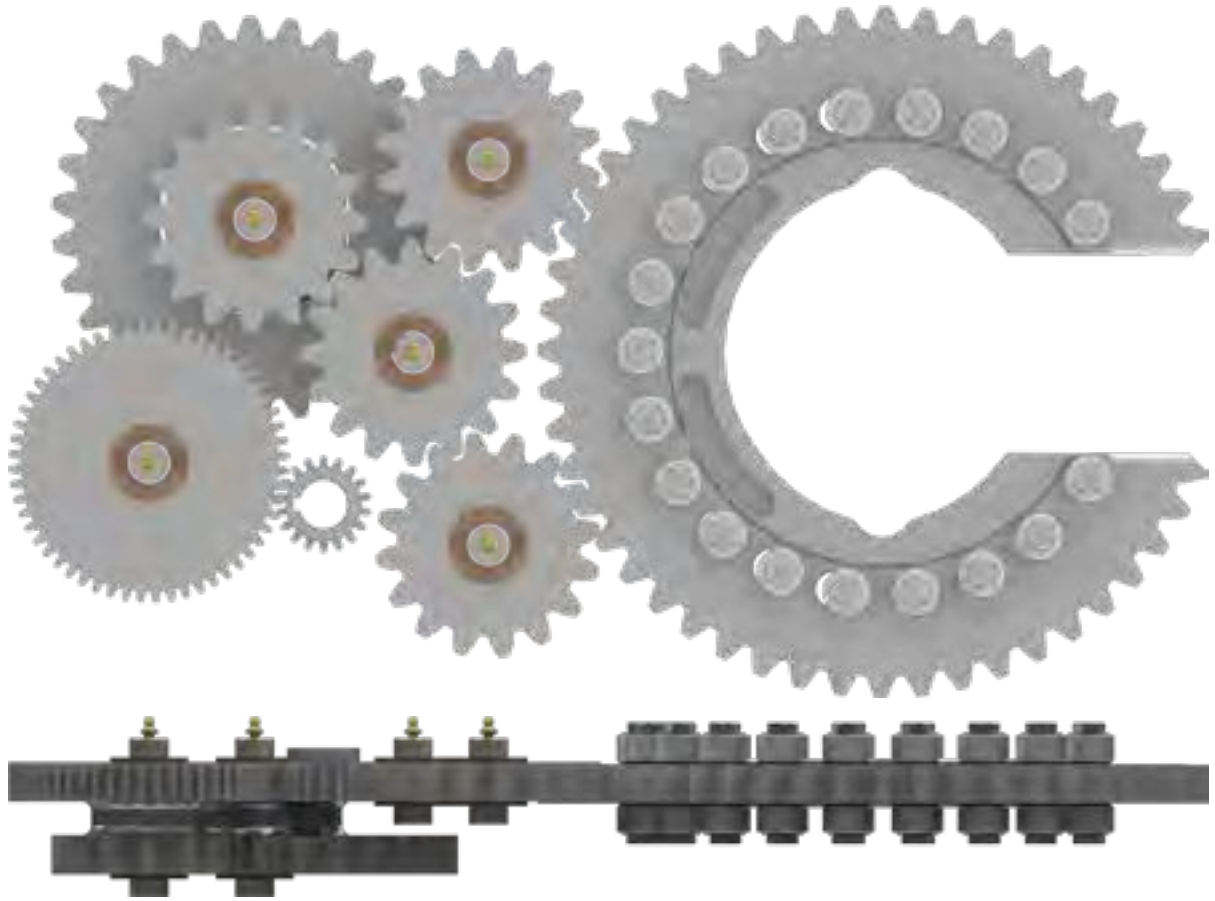

Item	Type	Description	Qty	Part Number
A	Part	Rotary Gear Assembly (See Pp. 5.12 - 5.13)	1	
B	Assembly	Idler Gear Assembly (See Pp. 5.4 - 5.5)	3	
C	Part	Motor Gear	1	101-4011
D	Assembly	Reduction Gear Assembly (See Pp. 5.6 - 5.7)	1	
E	Assembly	Reduction Gear Assembly (See Pp. 5.8 - 5.9)	1	

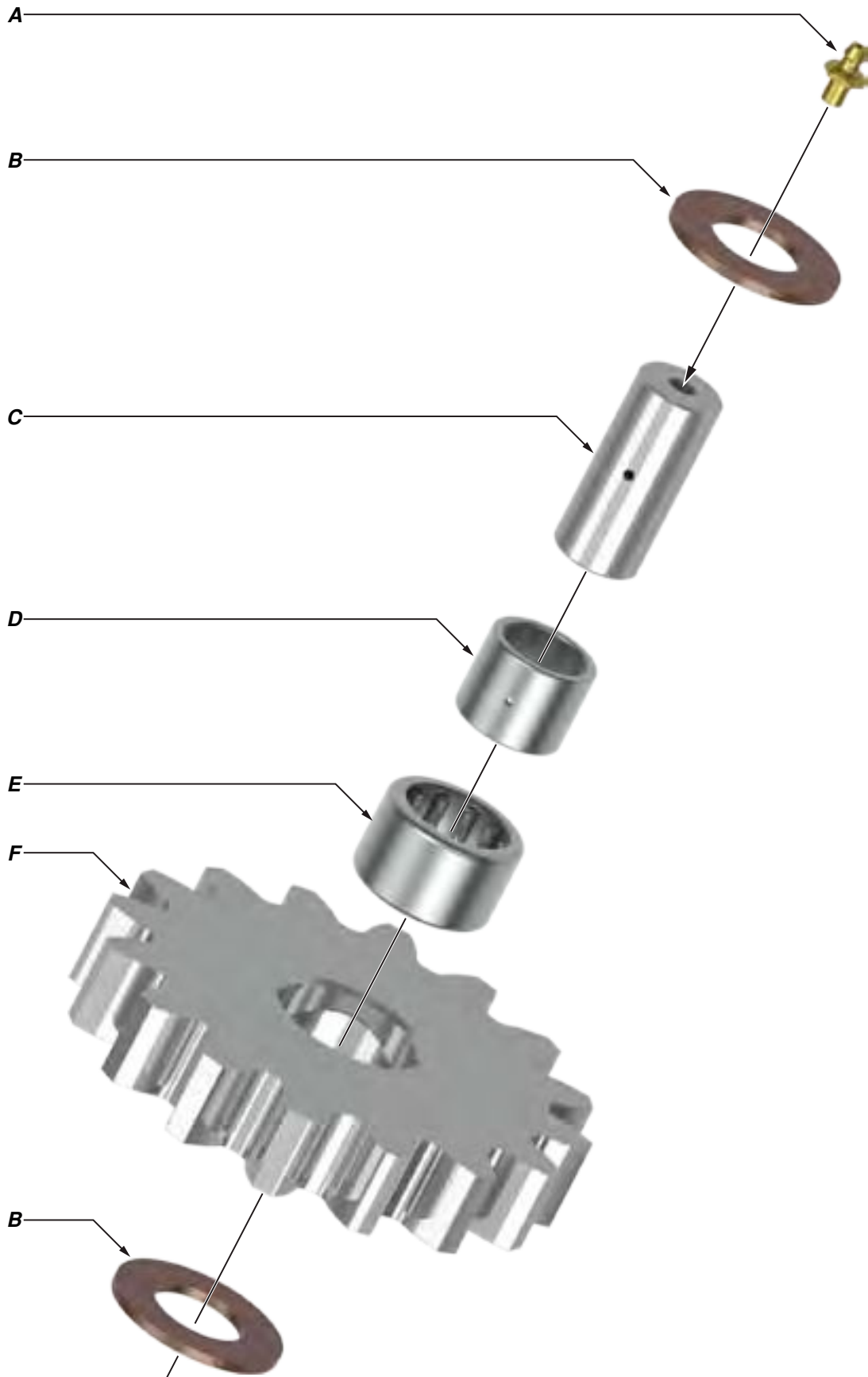



Item	Type	Description	Qty	Part Number
A	Part	Grease Fitting, 1/4" straight thread	1	02-0097
B	Part	Thrust Washer	2	02-E0001
C	Part	Shaft	1	101-3297
D	Part	Inner Ring 1" x 1-1/4" x 1-3/35"	1	02-9027
E	Part	Needle Roller Bearing Drawn Cup 1-1/4" x 1-5/8" x 1-5/55"	1	02-9009
F	Part	Idler Gear	1	101-3293

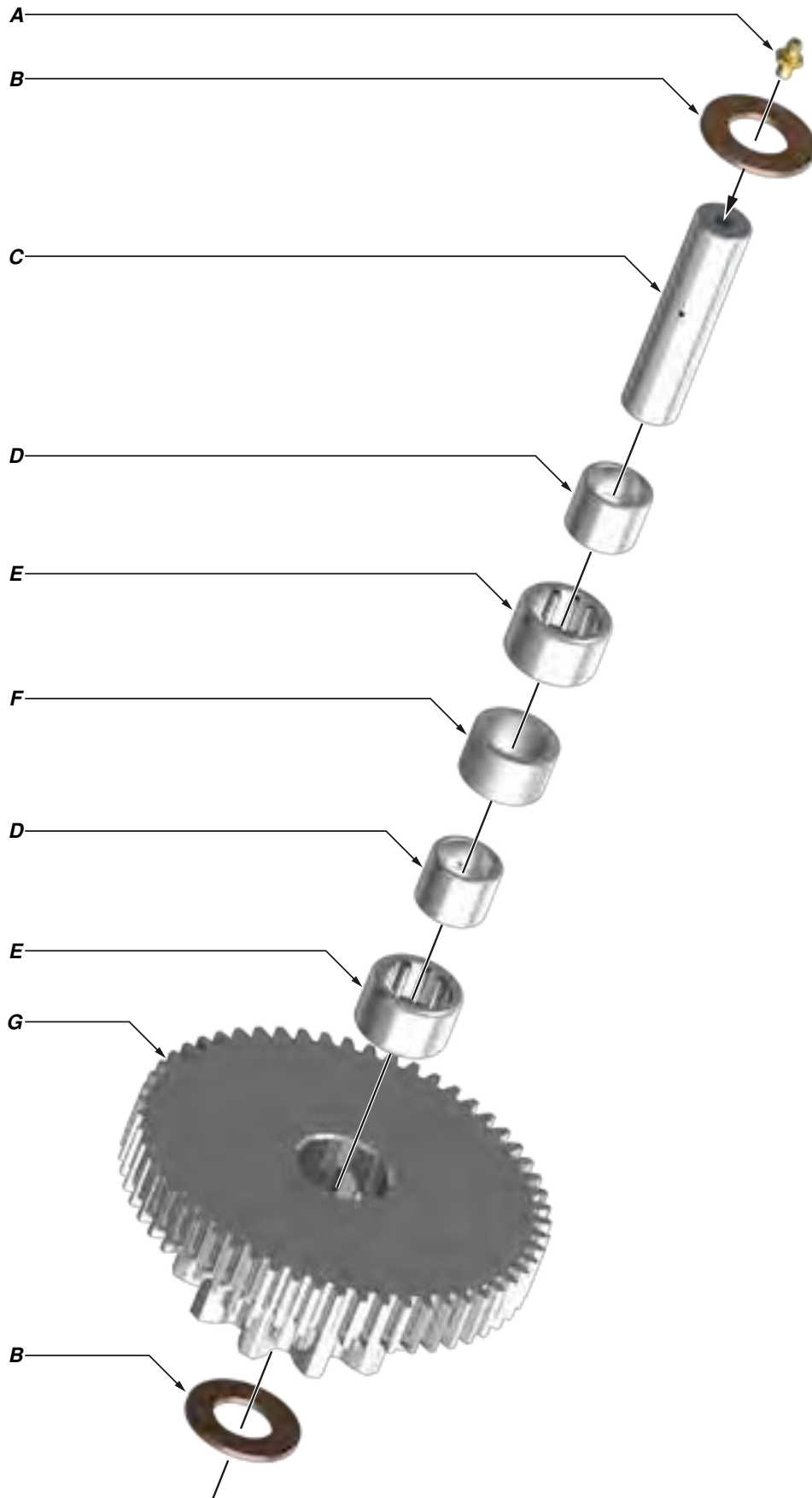



<i>Item</i>	<i>Type</i>	<i>Description</i>	<i>Qty</i>	<i>Part Number</i>
A	Part	Grease Fitting, 1/4" straight thread	1	02-0097
B	Part	Thrust Washer	2	02-E0001
C	Part	Gear Shaft	1	101-3296
D	Part	Inner Ring 1" x 1-1/4" x 1-3/35"	2	02-9027
E	Part	Needle Roller Bearing Drawn Cup 1-1/4" x 1-5/8" x 1-5/55"	2	02-9009
F	Part	Bearing Spacer	1	101-3812
G	Part	Reduction Gear	1	101-3291

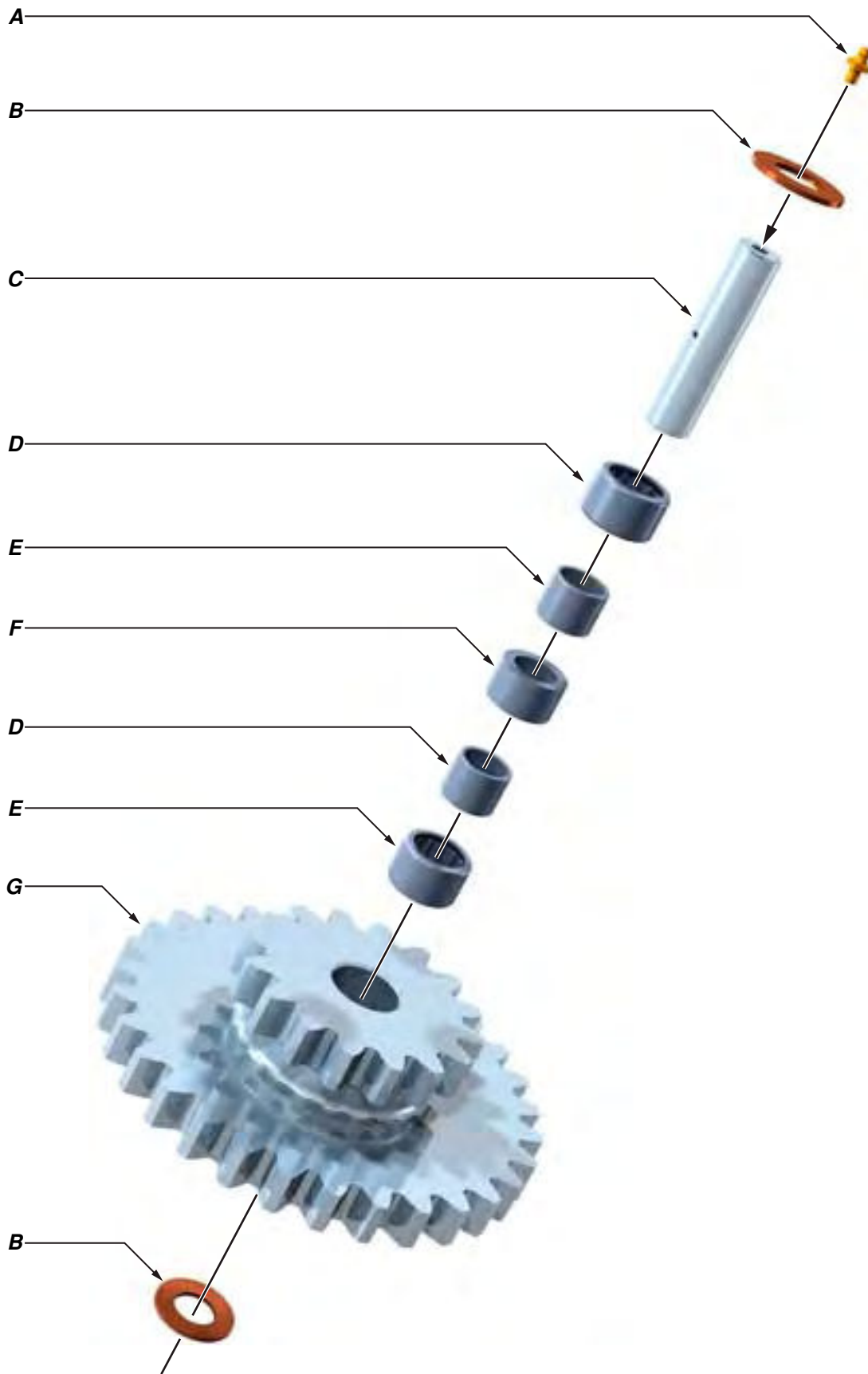



Item	Type	Description	Qty	Part Number
A	Part	Grease Fitting, 1/4" straight thread	1	02-0097
B	Part	Thrust Washer	2	02-E0001
C	Part	Gear Shaft	1	101-3296
D	Part	Needle Roller Bearing Drawn Cup 1-1/4" x 1-5/8" x 1-5/55"	2	02-9009
E	Part	Inner Ring 1" x 1-1/4" x 1-3/35"	2	02-9027
F	Part	Bearing Spacer	1	101-3812
G	Part	Reduction Gear	1	101-3292

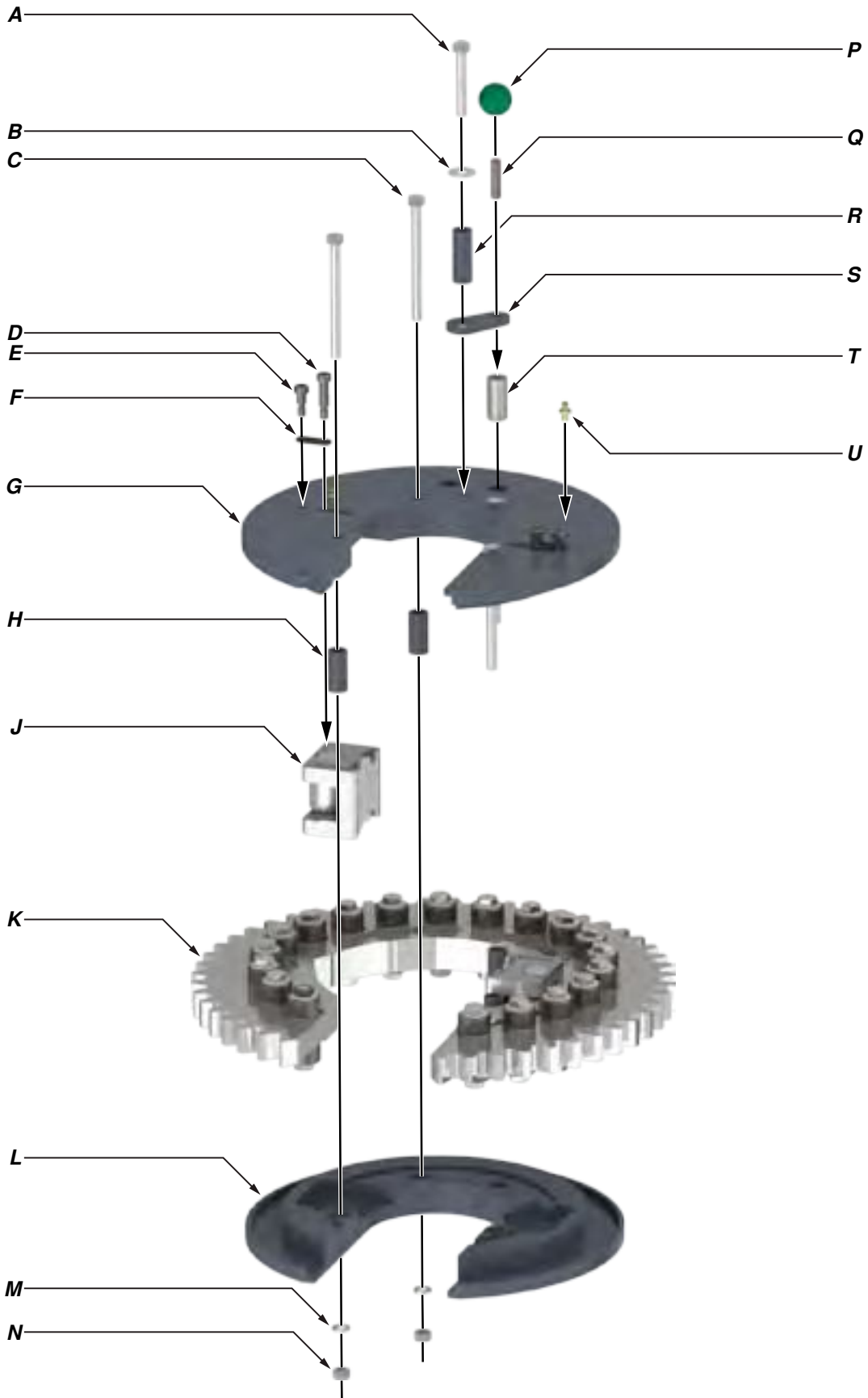



Item	Type	Description	Qty	Part Number
A	Part	3/8" UNC x 2-1/2" Hex Cap Screw	1	09-1056
B	Part	3/8" Flat Washer	1	09-5006
C	Part	3/8" UNC x 4-1/2" Hex Cap Screw	4	09-1064
D	Part	3/8" X 1" UNC Shoulder Bolt	2	09-1118
E	Part	3/8" X 1/2" UNC Shoulder Bolt	2	09-9179
F	Part	2-211 O-Ring	2	02-0340
G	Part	Top Cage Plate	1	101-3303
H	Part	Cage Plate Spacer	4	101-3333
J	Assembly	Jaw Die Kit (2-3/8" shown - see Pg. 2.8)	2	
K	Assembly	Rotary Gear Assembly (See Pp. 5.12 - 5.13)	1	
L	Part	Bottom Cage Plate	1	101-3304
M	Part	3/8" Lock washer	6	09-5106
N	Part	3/8" UNC Hex Nut	4	09-5806
P	Part	Knob	1	02-0017
Q	Part	3/8" UNC Stud	1	101-4058
R	Part	Backing Pin Bolt Spacer	1	101-4038
S	Part	Backing Pin Retainer	1	101-4040
T	Part	Backing Pin	1	101-4039
U	Part	1/4" Straight Thread Grease Fitting	2	02-0097

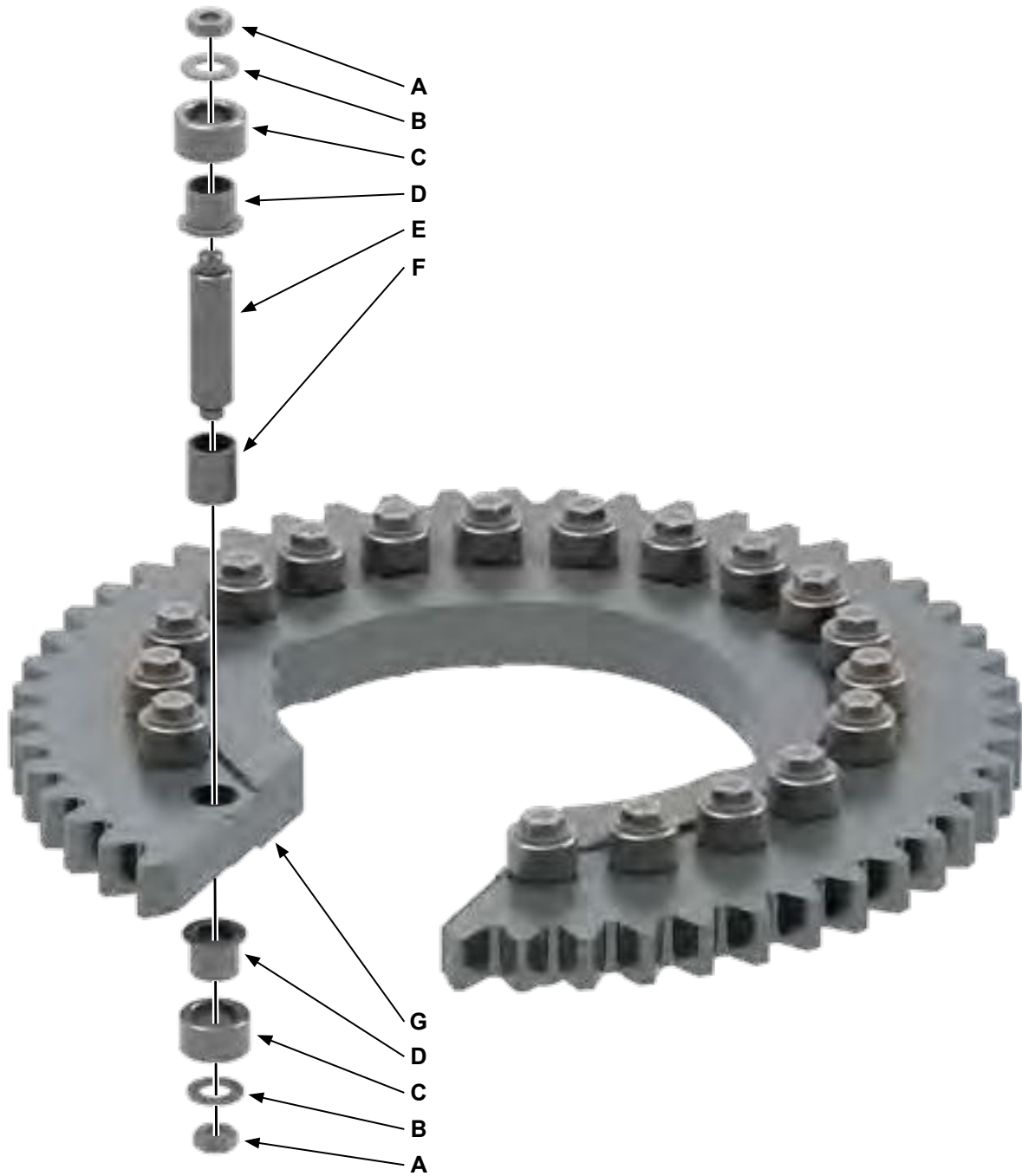



<i>Item</i>	<i>Type</i>	<i>Description</i>	<i>Qty</i>	<i>Part Number</i>
A	Part	7/16" Hex Jam Nut	38	02-E0005
B	Part	PTFE Thrust Washer	38	02-E0073
C	Part	Cam Roller	38	101-4019
D	Part	PTFE Shoulder Bushing	38	02-E0075
E	Part	Roller Shaft	19	101-4655
F	Part	Plain Bushing	19	02-E0074
G	Part	Rotary Gear	1	101-3301

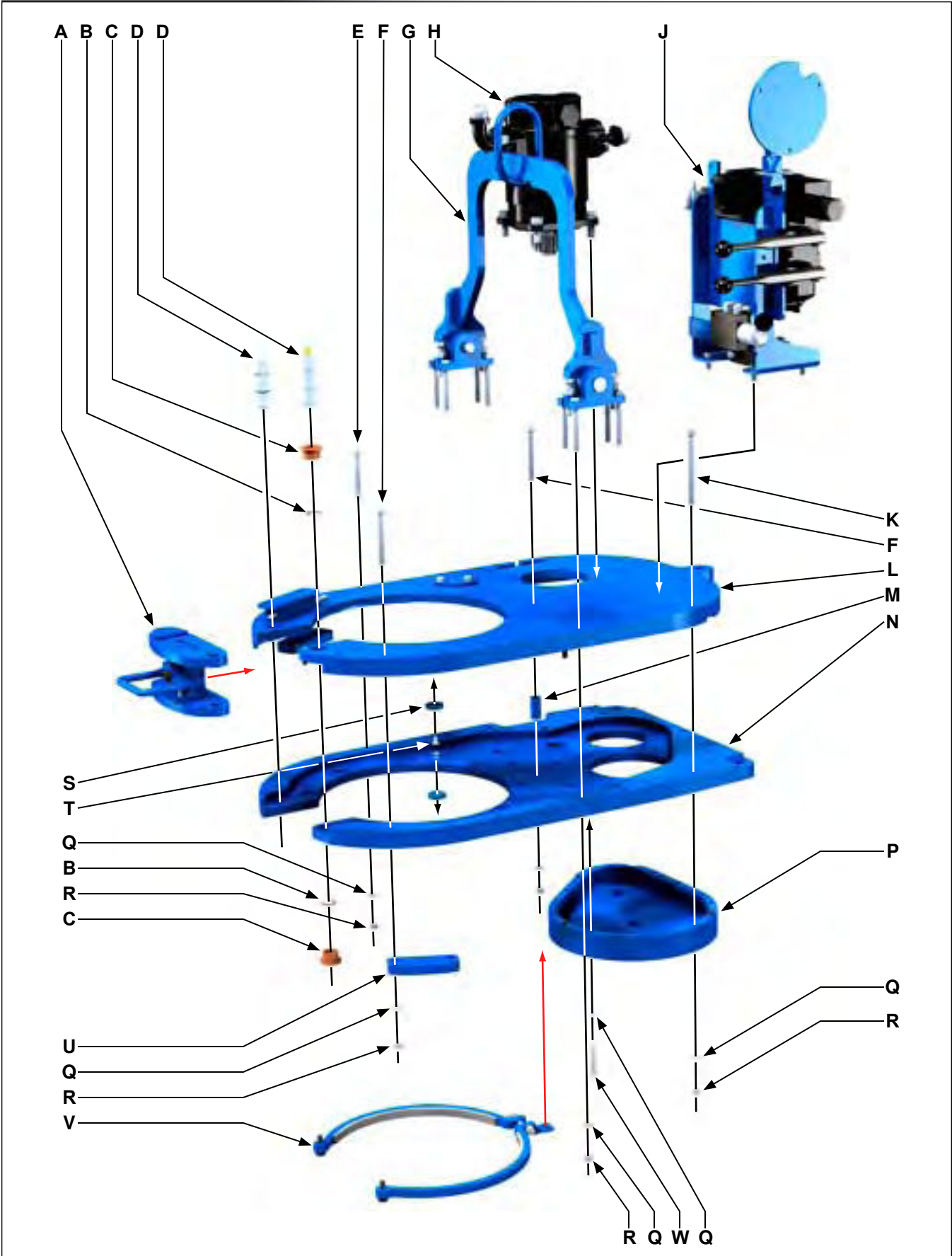



Item	Type	Description	Qty	Part Number
A	Assembly	Door Assembly (See Pp. 5.22 - 5.23)	1	
B	Part	External Snap Ring	4	02-E0004
C	Part	Shoulder Bushing	2	02-E0003
D	Part	Door Post	2	101-3306
E	Part	3/8" NC x 3" Hex Cap Screw	15	09-1058
F	Part	3/8" NC x 3-1/2" Hex Cap Screw	11	09-1060
G	Assembly	Rigid Sling Assembly (See Pp. 5.24 - 5.25)	1	
H	Assembly	Motor Assembly (See Pp. 5.18 - 5.19)	1	
J	Assembly	Hydraulic Valve Assembly (See Pp. 5.16 - 5.17)	1	
K	Part	3/8" NC x 5" Hex Cap Screw	4	09-1066
L	Part	Top Plate	1	101-3361
M	Part	Body Spacer	2	101-3333
N	Part	Bottom Plate	1	101-3362
P	Part	Gearbox Cover	1	101-3317
Q	Part	3/8" Lock washer	44	09-5106
R	Part	3/8" NC Hex Nut	30	09-5806
S	Part	Wear Button	16	101-3389
T	Part	1/4" NC x 1/2" Hex Socket FHCS	16	09-4003
U	Part	Leg Plate (typ. welded to front leg weldment - shown for illustration)	2	101-4034
V	Weldment	Lined Brake band Weldment (See Pp. 5.20 - 5.21)	2	101-3393
W	Part	3/8" NC x 2-1/2" Hex Bolt	4	09-1056

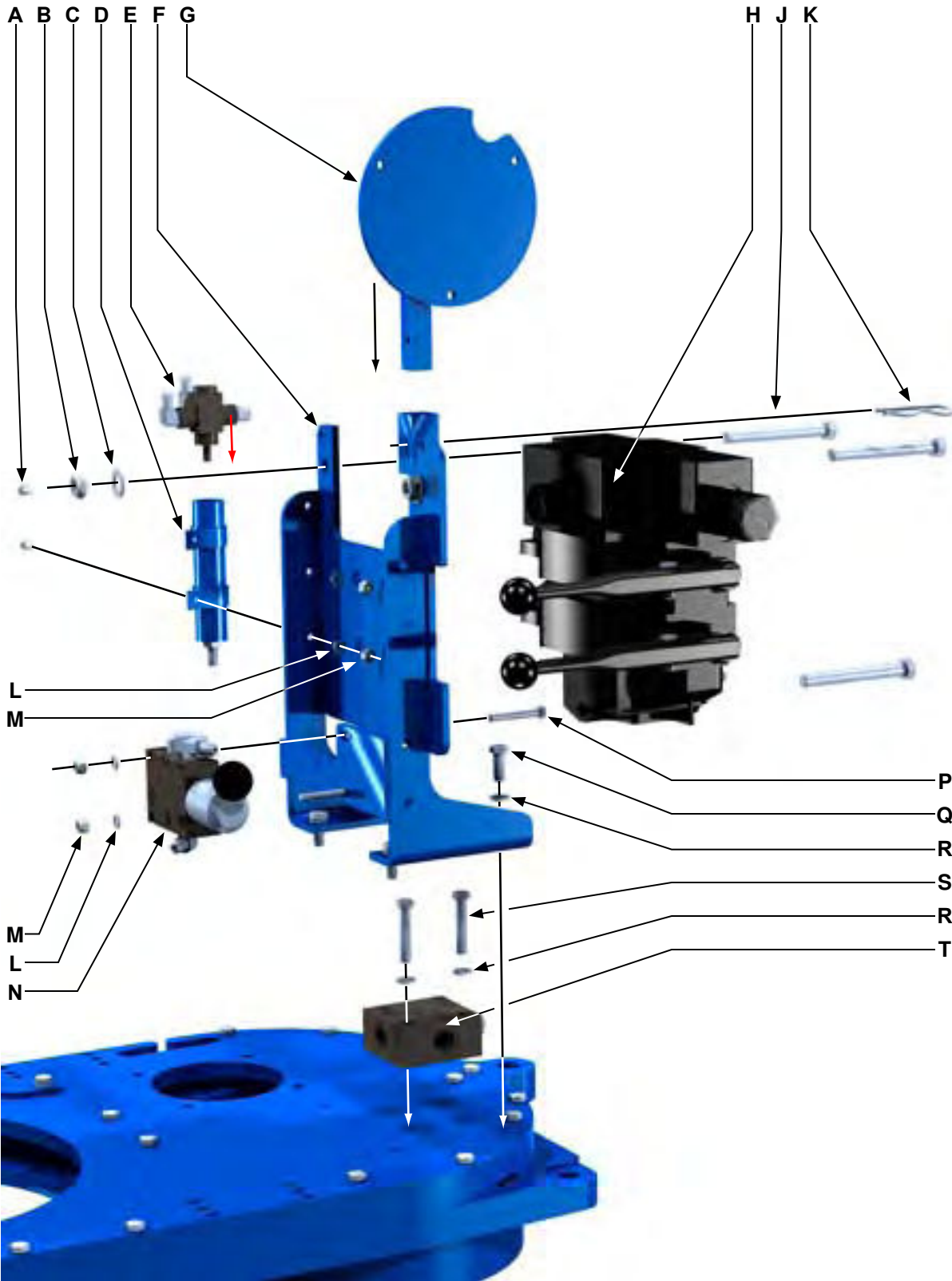

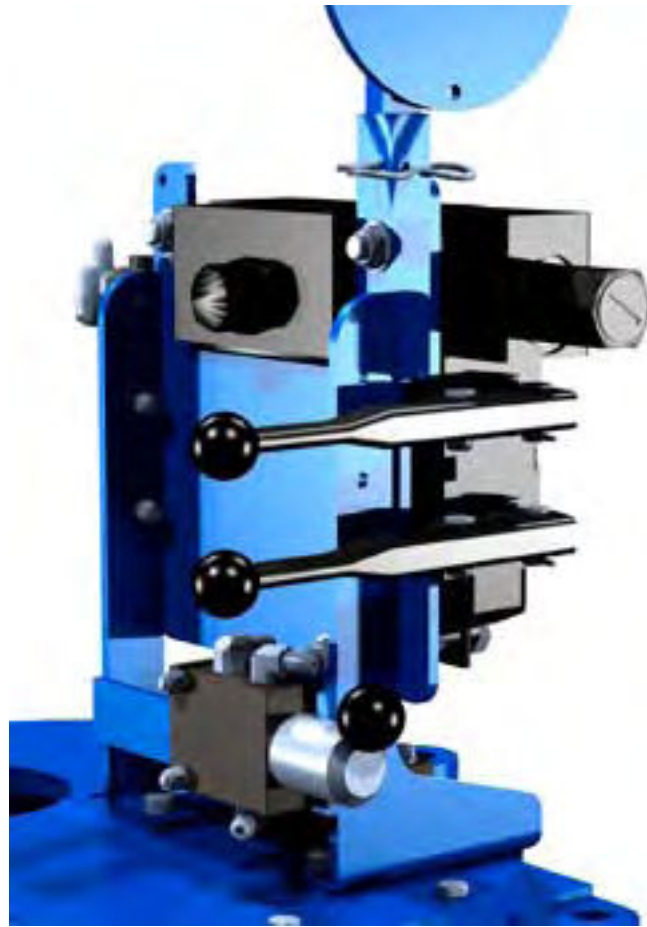

Item	Type	Description	Qty	Part Number
A	Part	1/4" NC x 3/4" Hex Cap Screw	2	09-1005
B	Part	1/2" NC Thin Nylock Nut	3	09-5610S
C	Part	1/2" Narrow Washer	3	09-5119
D	Part	Cable Guide Holder	1	101-4236
	Part	Cable Guide Holder Retainer	2	02-E0025
E	Part	Safety Door Valve	1	08-0337
	Part	1/4" NPT 90 Degree Fitting	6	08-0284
F	Weldment	Valve Mount	1	101-4101
G	Weldment	Torque Gauge Mount	1	101-4403
H	Assembly	DVA35 Valve Assembly	1	VARIABLES
J	Part	1/2" NC x 4-1/2" Hex Cap Screw	3	09-1184
K	Part	HITCH PIN .148 X 2.938:1	1	
L	Part	1/4" Narrow Washer	4	09-1119
M	Part	1/4" NC Nylock Nut	4	09-5701
N	Part	Valve	1	10-9024A
P	Part	1/4" NC x 2" Hex Cap Screw	2	09-1015
Q	Part	3/8" NC x 1" Hex Cap Screw	4	09-1046
R	Part	3/8" Lock washer	6	09-5106
S	Part	3/8" NC x 2" Hex Cap Screw	4	09-1054
T	Part	Valve Body	1	08-1327

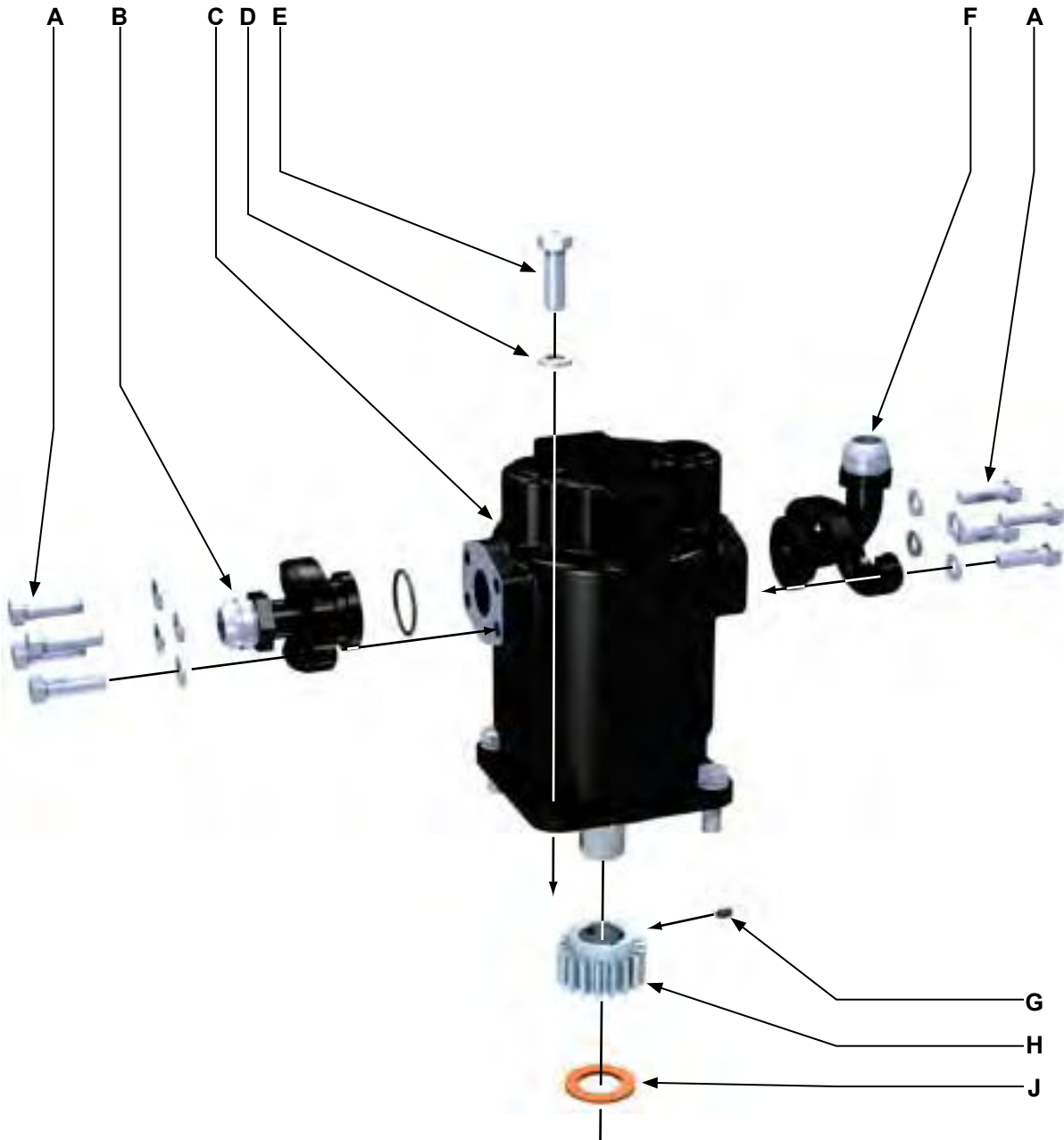



Item	Type	Description	Qty	Part Number
A	Part	#20 (1-1/4") Split Flange Kit	2	02-9217
	Part	O-Ring	2	
	Part	#20 (1-1/4") Split Flange	4	
	Part	7/16" Lock washer	8	
	Part	7/16" NC x 1-1/2" Hex Bolt	8	
B	Part	Flange Fitting	1	02-E0022
C	Part	RINEER GA 15-13/6.5 (2 SPEED) Hydraulic Motor	1	87-0008
D	Part	1/2" Lock washer	4	09-5110
E	Part	1/2" NC x 1-1/2" Hex Cap Screw	4	09-1170
F	Part	90 Degree Flange Fitting	1	02-9216
G	Part	1/4" NC x 3/8" Hex Socket Set Screw	2	09-0107
H	Part	Motor Gear	1	101-4011
J	Part	Thrust Washer	1	02-E0009
K	Part	Square Motor Key 5/16" x 5/16" x 1-3/4" (Not Shown)	1	

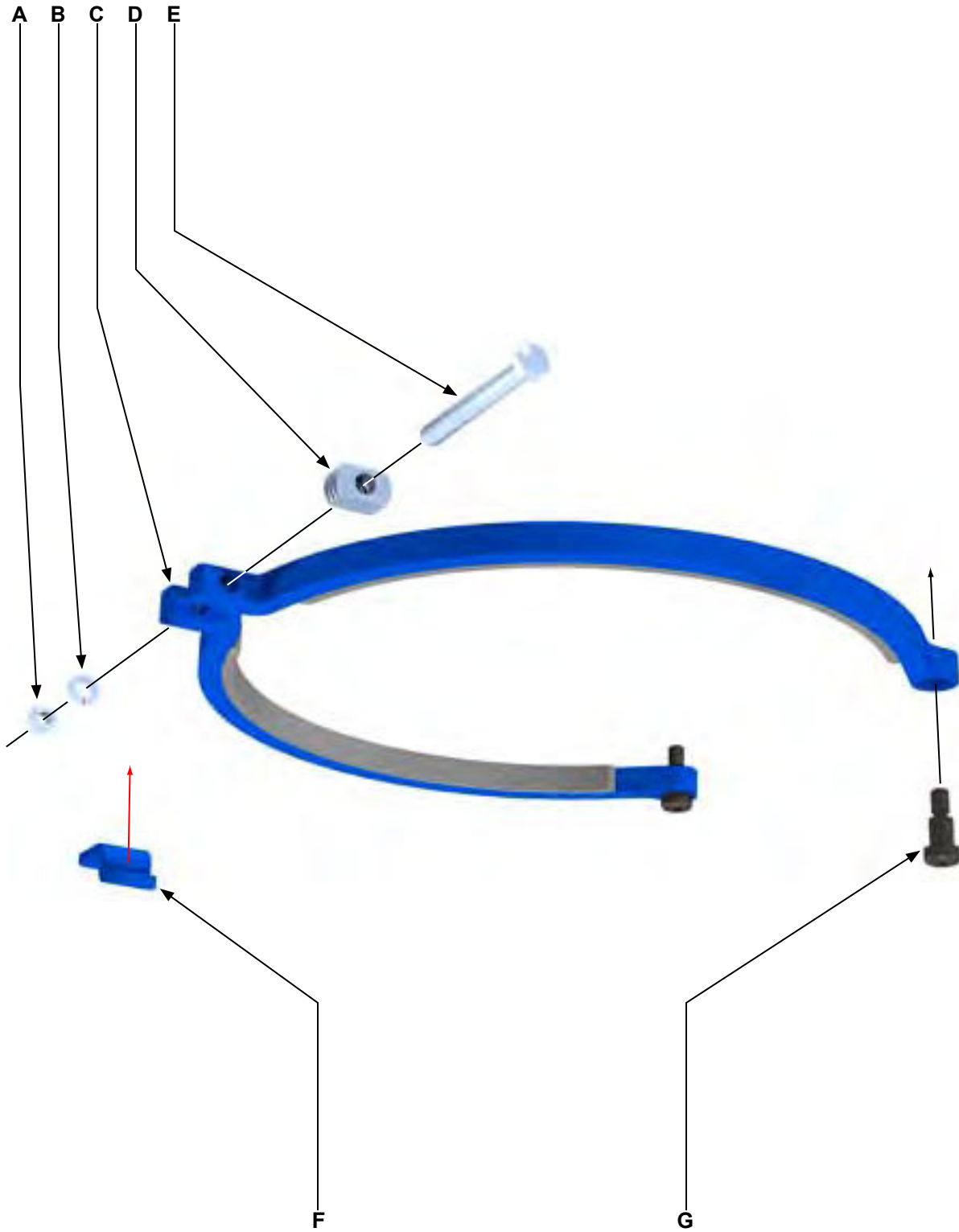

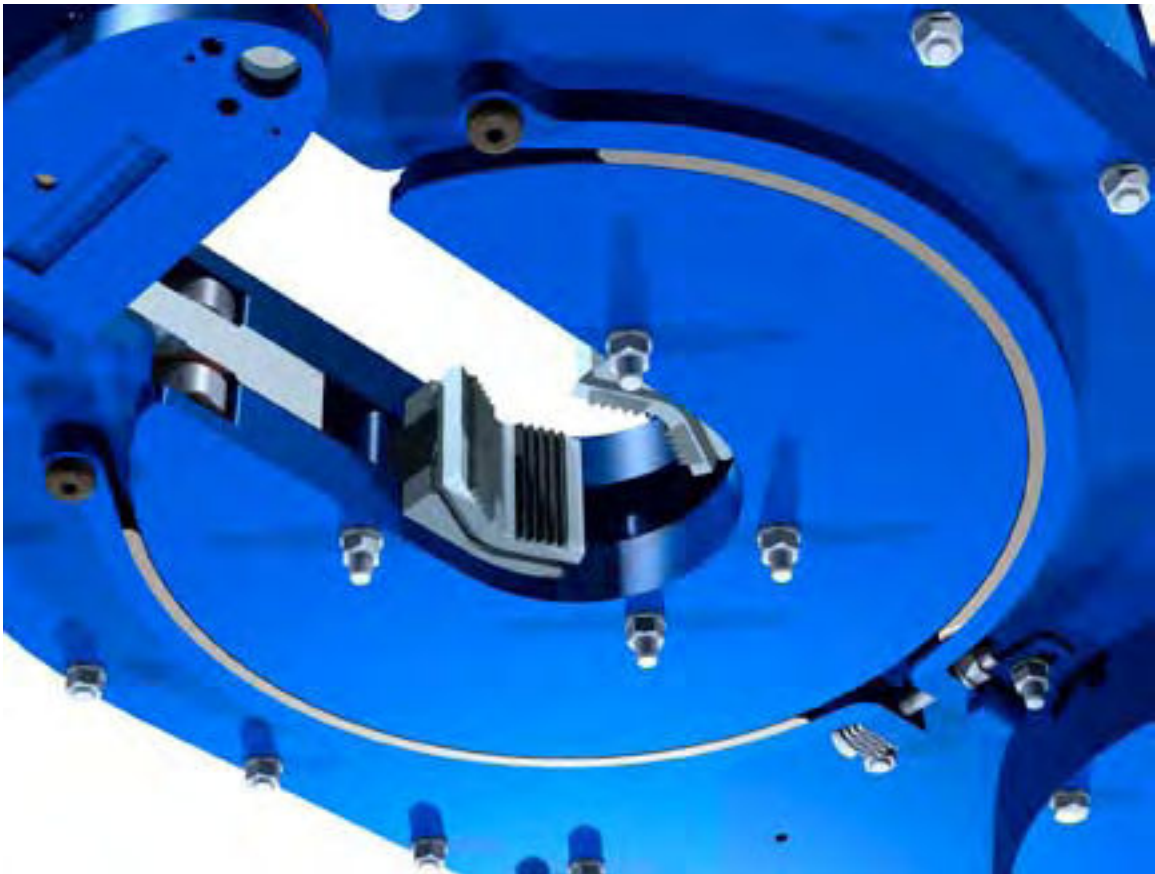

<i>Item</i>	<i>Type</i>	<i>Description</i>	<i>Qty</i>	<i>Part Number</i>
A	Part	3/8" NC Hex Nut	1	09-5806
B	Part	3/8" Lock washer	1	09-5106
C	Weldment	Lined Brake band Weldment	2	101-3393
D	Assembly	Belleville Washer Assembly	8	101-3272
E	Part	3/8" NC x 3-1/4" Hex Cap Screw	1	09-1059
F	Part	Brake band Retainer	1	101-3975
G	Part	3/8" x 5/8" Shoulder Bolt	2	02-E0045

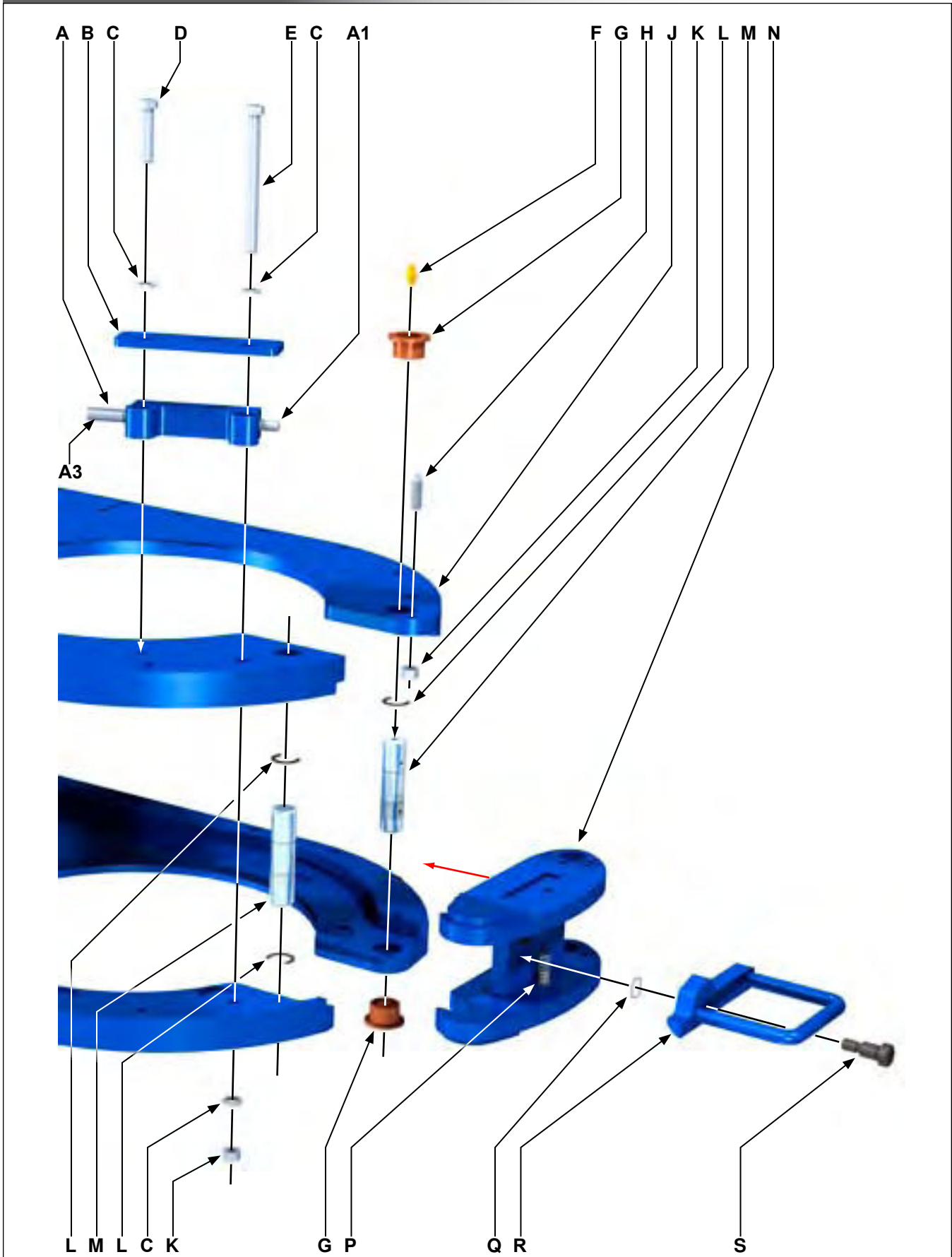

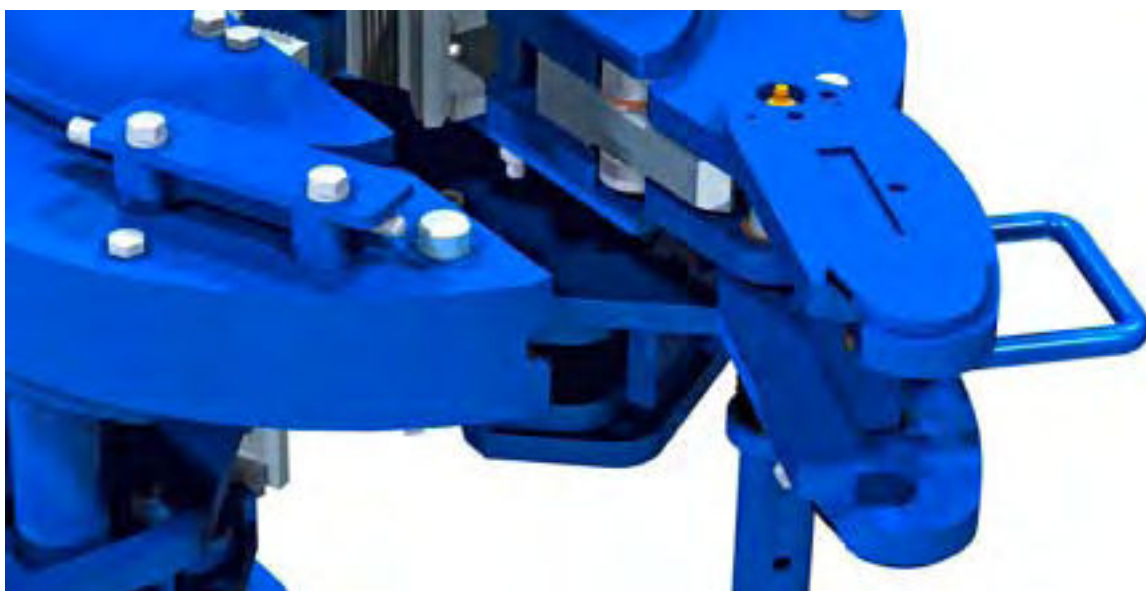

Item	Type	Description	Qty	Part Number
A	Part	Cable Guide Holder	1	101-4235
A1	Part	Safety Door Plunger	1	101-4360
A2	Part	Push-Pull Control Cable	1	02-E0026
A2	Part	7/16" UNF Hex Jam Nut	1	09-5508
B	Part	Cable Guide Guard	1	101-4237
C	Part	3/8" Lock washer	2	09-5106
D	Part	3/8" NC x 1-3/4" Hex Cap Screw	1	09-1557
E	Part	3/8" NC x 4-1/2" Hex Cap Screw	1	09-1064
F	Part	1/4" Straight Thread Grease Fitting	1	02-0097
G	Part	Shoulder Bushing	2	02-E0003
H	Part	Detent c/w button	1	02-0899
J	Part	Top Plate (shown for illustration)	1	101-3361
K	Part	3/8" NC Hex Nut	2	09-5806
L	Part	External Snap Ring	4	02-E0004
M	Part	Door Post	2	101-3306
N	Weldment	Door Weldment	1	101-4300
P	Part	Compression Spring	1	C0460-0050-1125
Q	Part	Wave Spring	1	02-9267
R	Part	Latch Weldment	1	101-3530
S	Part	3/8" x 3/4" Shoulder Bolt	1	09-0223

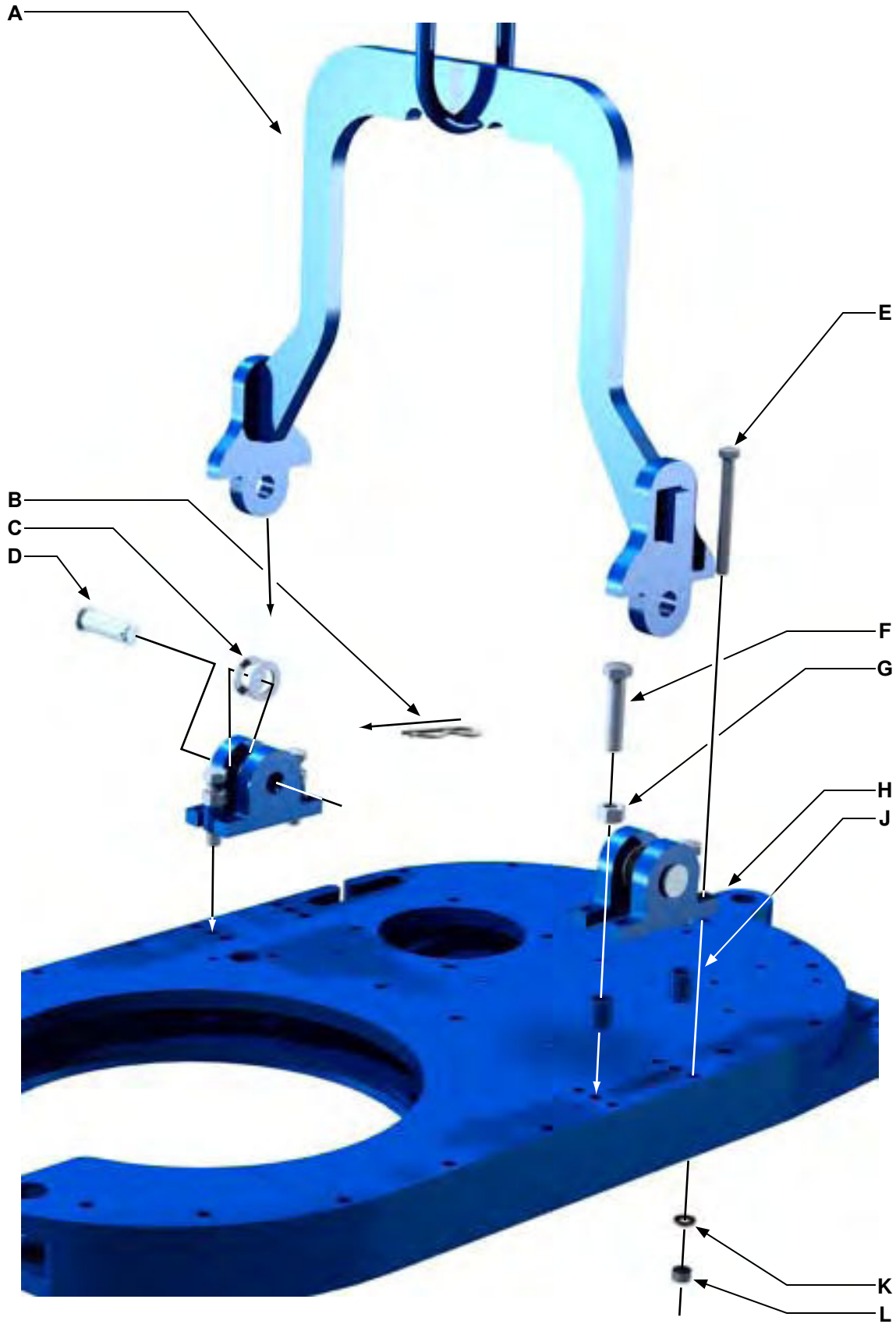



Item	Type	Description	Qty	Part Number
A	Weldment	Rigid Sling Weldment	1	101-4137
B	Part	0.148" x 2.938" Hitch Pin	2	02-0028
C	Part	3/4" Narrow Washer	4	09-5013
D	Part	Rigid Sling Pin	2	02-E0008
E	Part	3/8" NC x 3-1/2" Hex Cap Screw	8	09-1060
F	Part	Rigid Sling Leveling Bolt	4	02-E0038
G	Part	1/2" NC Hex Nut	4	09-9124
H	Part	Rigid Sling Lifting Lug	4	101-3337
J	Part	Rigid Sling Adjustment Bolt Spacer	4	101-4138
K	Part	3/8" Lock washer	8	09-5106
L	Part	3/8" NC Hex Nut	8	09-5806

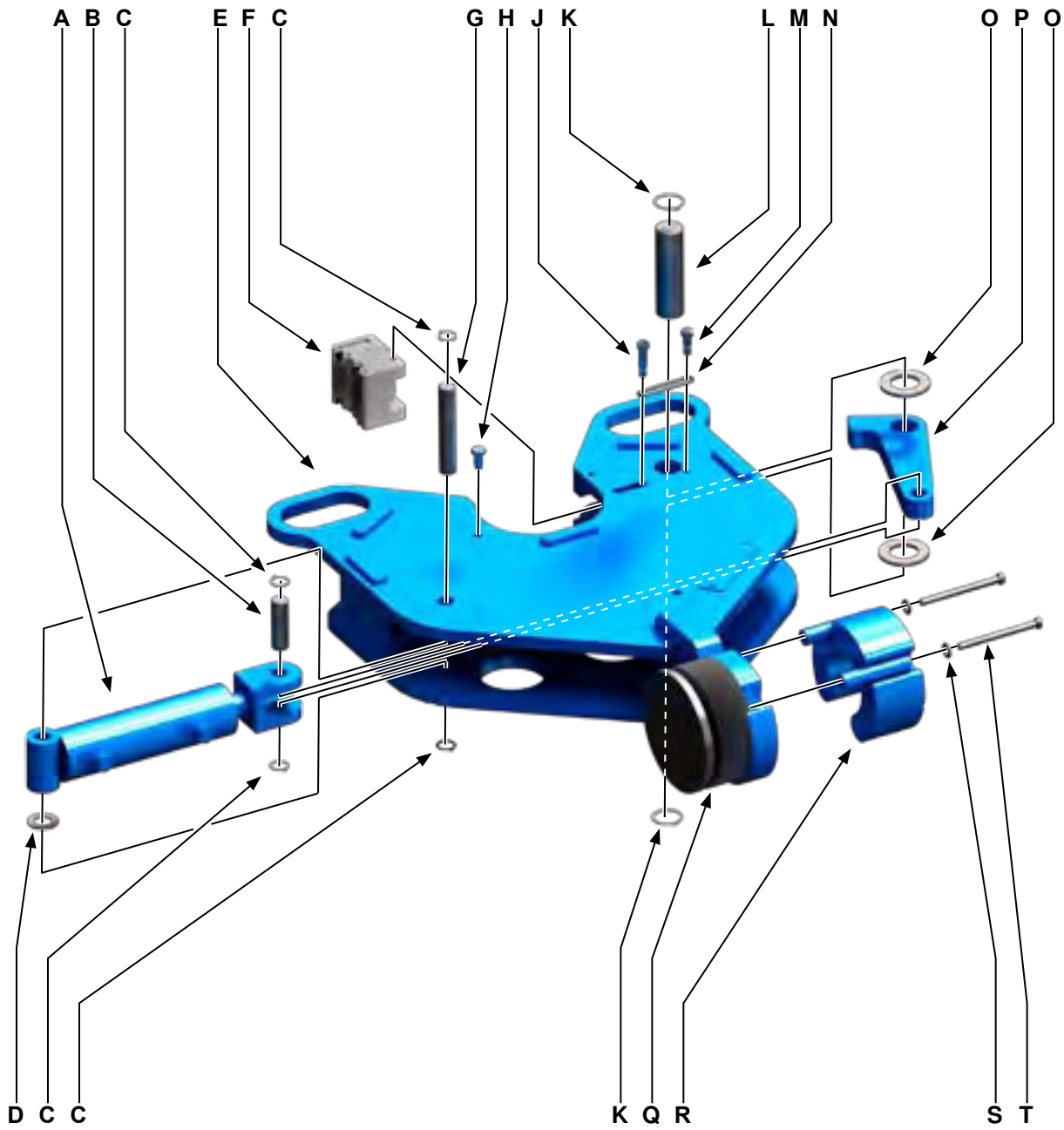



Item	Type	Description	Qty	Part Number
A	Assembly	Hydraulic Cylinder Assembly	1	101-4336
B	Part	Cylinder Pin	1	101-3676
C	Part	External Retaining Ring	4	02-E0036
D	Part	3/4" Narrow Flat washer	1	09-5013
E	Weldment	Backup Body Weldment	1	101-4337
F	Assembly	Jaw Die Kit (2-3/8" shown - see Pg. 2.13)	2	
G	Part	Cylinder Pin	1	101-4329
H	Part	Jaw Retainer Bolt	2	101-4264
J	Part	3/8" x 1" UNC Socket Head Shoulder Screw	1	09-1118
K	Part	External Retaining Ring	2	02-E0037
L	Part	Lever Pin	1	101-4330
M	Part	3/8" x 1/2" UNC Socket Head Shoulder Screw	1	09-9179
N	Part	2-213 O-Ring	1	02-0347
O	Part	1-1/4" Plain Narrow Washer	2	02-E0043
P	Part	Cam Arm	1	101-3672
Q	Part	Compression Load Cell, CC-108	1	10-0008C
R	Weldment	Load Cell Holder Weldment	1	101-4340
S	Part	5/16" Narrow Flat washer	2	02-E0044
T	Part	5/16" NC x 4" Hex Cap Screw	2	09-1024

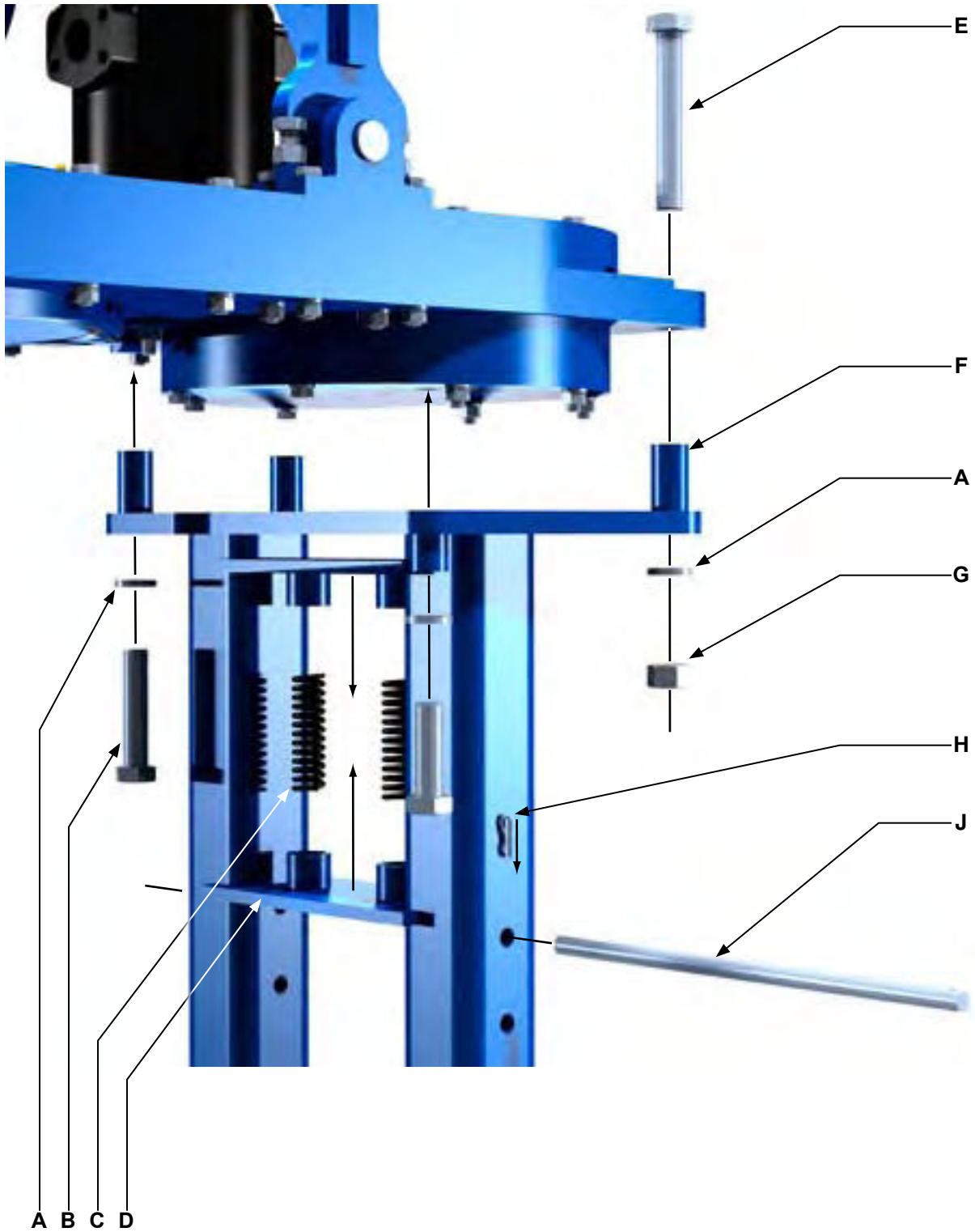



Item	Type	Description	Qty	Part Number
A	Part	3/4" Lock washer	4	09-5118
B	Part	3/4" NC x 3-1/2" Hex Cap Screw	1	09-1300
C	Part	Rear Leg Spring	2	997-13
D	Weldment	Backup Support Plate	2	101-3885
E	Part	3/4" NC x 5" Hex Cap Screw	1	09-1306
F	Weldment	Rear Leg Weldment	1	101-3883
G	Part	3/4" Hex Nut	2	09-5818
H	Part	0.093" x 1.125" Hitch Pin	2	02-E0046
J	Part	Support Rod	1	101-3891

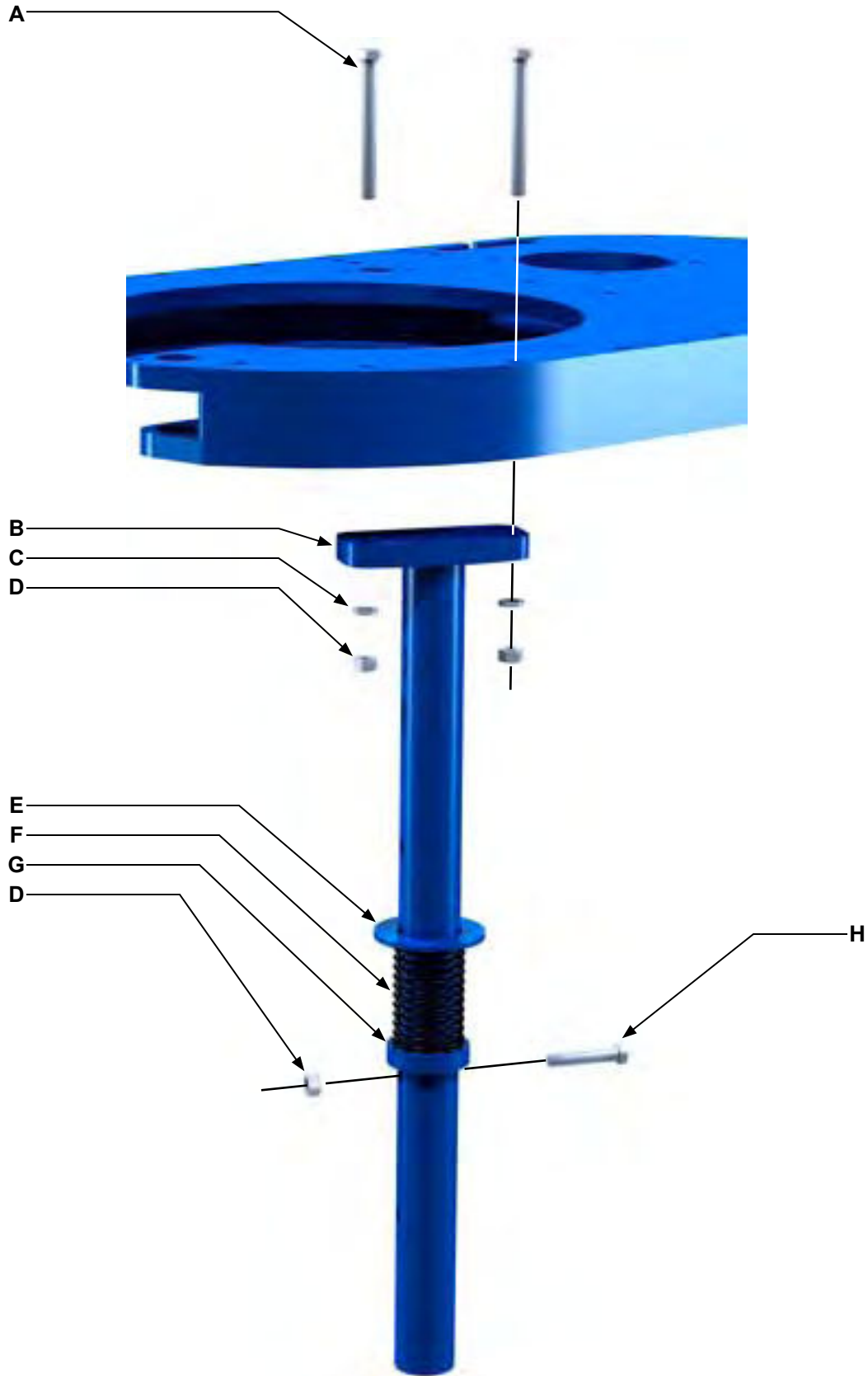



<i>Item</i>	<i>Type</i>	<i>Description</i>	<i>Qty</i>	<i>Part Number</i>
A	Part	3/8" NC x 3-1/2" Hex Cap Screw	4	09-1060
B	Weldment	Front Leg Weldment	2	101-3661
C	Part	3/8" Lock washer	8	09-5106
D	Part	3/8" NC Hex Nut	8	09-5806
E	Part	1-5/8" Plain Narrow Flat washer	2	101-4446
F	Part	Leg Spring	2	02-0920
G	Part	Bottom Spring Support	2	101-4339
H	Part	3/8" NC x 2" Hex Cap Screw	2	09-1054



***This page intentionally
left blank***

A. BASIC TORQUE MEASUREMENT

Basic torque measurements are performed using a simple hydraulic measurement system. A hydraulic load cell connects to a calibrated torque gauge through a reinforced flexible hydraulic hose. The torque gauge is factory-calibrated to display accurate torque measurements for a tong or tong and backup assembly with a particular arm length. The arm length is a measurement from the centre of the pipe or casing to the centre of the force being applied to the load cell.

Two load cell options are available. A tension load cell is typically used with a suspended stand-alone tong. This application requires that the load cell be attached to the rear of the tong as part of the restraint line that opposes the force generated when the tong makes up or breaks out a joint. A compression load cell is used in a tong and backup assembly, and is typically located on the rear of the backup between the backup and a stationary frame. The load cell must be located in the centre of the compression force vector generated between the backup and the frame.

Hydraulic force generated by a load cell is transmitted to the torque gauge via a reinforced flexible hydraulic line. The hydraulic force is displayed as torque in units of Ft.-Lbs. The torque gauge has a red "peak torque" indicator that tracks with the torque gauge needle to the point of highest torque, and remains at the point of highest torque until manually reset. Note that every model of tong and tong and backup assembly has a unique arm length, and the torque gauge must be calibrated for that arm length. Torque gauges that are not calibrated for the arm length of the tool in service will not display correct torque. To ensure correct torque measurement, ensure the arm length or "handle" as displayed on your torque gauge matches the arm length of the tool in service as listed on the specifications page of the technical manual.

The images on this page are for illustration purposes only and may not accurately represent the torque gauge and load cell that have been supplied with your equipment.



THE IMAGES DISPLAYED ARE SUPPLIED FOR ILLUSTRATION PURPOSES ONLY



ILLUSTRATION 6.A.1: TORQUE GAUGE (FOR ILLUSTRATION PURPOSES ONLY)



ILLUSTRATION 6.A.2: TENSION LOAD CELL



ILLUSTRATION 6.A.3: COMPRESSION LOAD CELL

Torque gauges and load cells are supplied as a matched calibrated pair. Substituting one or the other will render the calibration inaccurate even if the actual model numbers appear to be identical. The serial numbers of matching load cell and torque gauges are clearly identified on the calibration certificate. Should you suspect the accuracy of your torque measurements, or wish to replace either component the pair should be returned to the factory for re-calibration before placing into service.



TORQUE GAUGES AND LOAD CELLS ARE FACTORY-SUPPLIED SUPPLIED AS MATCHED CALIBRATED PAIRS. IF REPLACING EITHER COMPONENT THE LOAD CELL AND TORQUE GAUGE MUST BE RETURNED TO THE FACTORY FOR RE-CALIBRATION BEFORE PLACED INTO SERVICE.

BASIC TORQUE MEASUREMENT (Continued:)

The images on the preceding page are for illustration purposes only and may not accurately represent the torque gauge and load cell that have been supplied with your equipment. Please note that the parts listed in the following table are correct for accurate torque measurement while using the equipment for which this manual is supplied.



THE TORQUE GAUGE USED IS FULLY DEPENDANT UPON THE ARM LENGTH AND TORQUE RANGE OF THE EQUIPMENT IN USE. THE PART NUMBERS LISTED IN THE FOLLOWING TABLES ARE CORRECT FOR ACCURATELY MEASURING TORQUE USING THE EQUIPMENT FOR WHICH THIS MANUAL IS SUPPLIED.

Item	Type	Description	Qty	Part Number
	Assembly	24" Arm - 8000 Lbs.-Ft. Torque Gauge / Tension Load Cell Assembly	1	10-0025T
1	Part	24" Arm 8,000 Lbs.-Ft Torque Gauge	1	10-0025G
2	Part	Tension Load Cell, 4.08 in ²	1	10-0008T
3	Part	Hydraulic Hose	1	02-0069

Item	Type	Description	Qty	Part Number
	Assembly	18" Arm - 4K/ 8.5K Torque Gauge / Comp. Load Cell Assembly	1	10-0025C
1	Part	18" Arm 8,500 Lbs.-Ft Torque Gauge	1	10-0025G
2	Part	Compression Load Cell, 8 in ²	1	10-0008C
3	Part	Hydraulic Hose	1	02-0069

Item	Type	Description	Qty	Part Number
	Assembly	Tension Load Cell, 4.08 in ²	1	10-0008T
A	Part	O-Ring	1	02-0800
B	Part	Load Cell Body	1	LC99-104
C	Part	1/4" NC x 1/2" Binding Head Machine Screw	1	09-0045A
D	Part	Stat-O-Seal	1	02-0307
E	Part	O-Ring	1	02-0350
F	Part	O-Ring	1	08-0596
G	Part	Load Cell Piston	1	LC99-101
H	Part	Load Cell End	1	LC99-003
J	Part	Flange Gasket	1	02-0073
K	Part	Load Cell Rod	1	LC99-002
L	Part	Wiper	1	08-1558
M	Part	3/8" NC x 3/8" Cup Point Hex Set Screw	2	09-0106
Seal Kit				Replacement Seal Kit 4.08 in ² Tension Load Cell
				02-4578

This is the standard tension load cell supplied by McCoy Drilling & Completions / Farr. Contact our sales department for information about optional application-specific tension load cells.

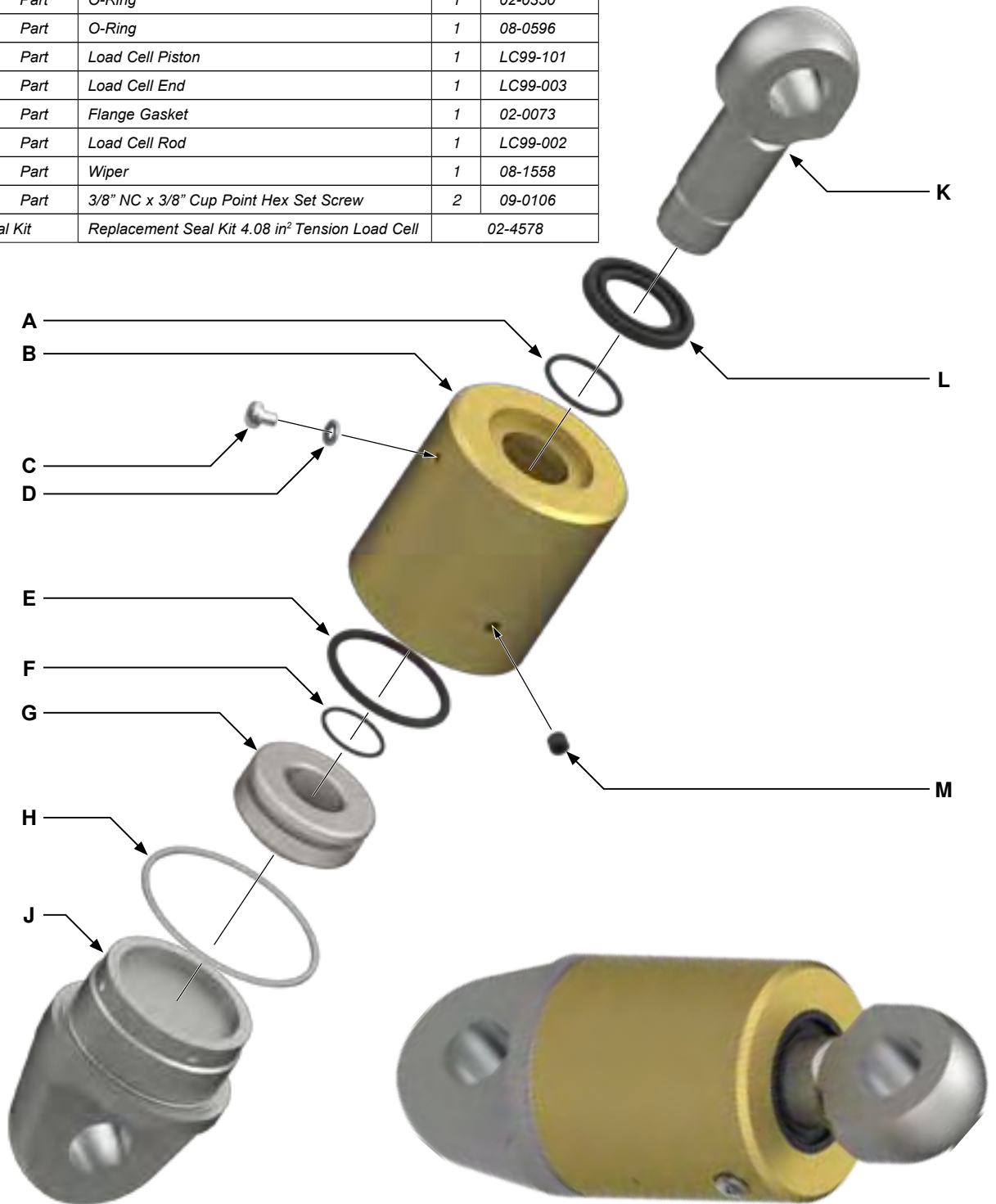

ILLUSTRATION 6.A.4: TENSION LOAD CELL EXPLODED

Item	Type	Description	Qty	Part Number
	Assembly	Compression Load Cell, 8 in ²	1	10-0008C
A	Part	5/16" UNC x 1" Hex Socket Head Cap Screw	1	09-2026
B	Part	Load Plate	1	E360-A
C	Part	5/16" UNC x 3/4" Hex Socket Head Cap Screw	6	09-2024
D	Part	Retainer Ring	1	E360-8
E	Part	Diaphragm	1	E358-2
F	Part	Diaphragm Casing	1	E360-C
G	Part	Street Elbow	1	
H	Part	1/4" NPT Brass Plug	1	

This is the standard hydraulic compression load cell supplied by McCoy Drilling & Completions | Farr. Contact our sales department for information about optional application-specific compression load cells.

Electronic compression load cells are used for some WinCatt™ applications.

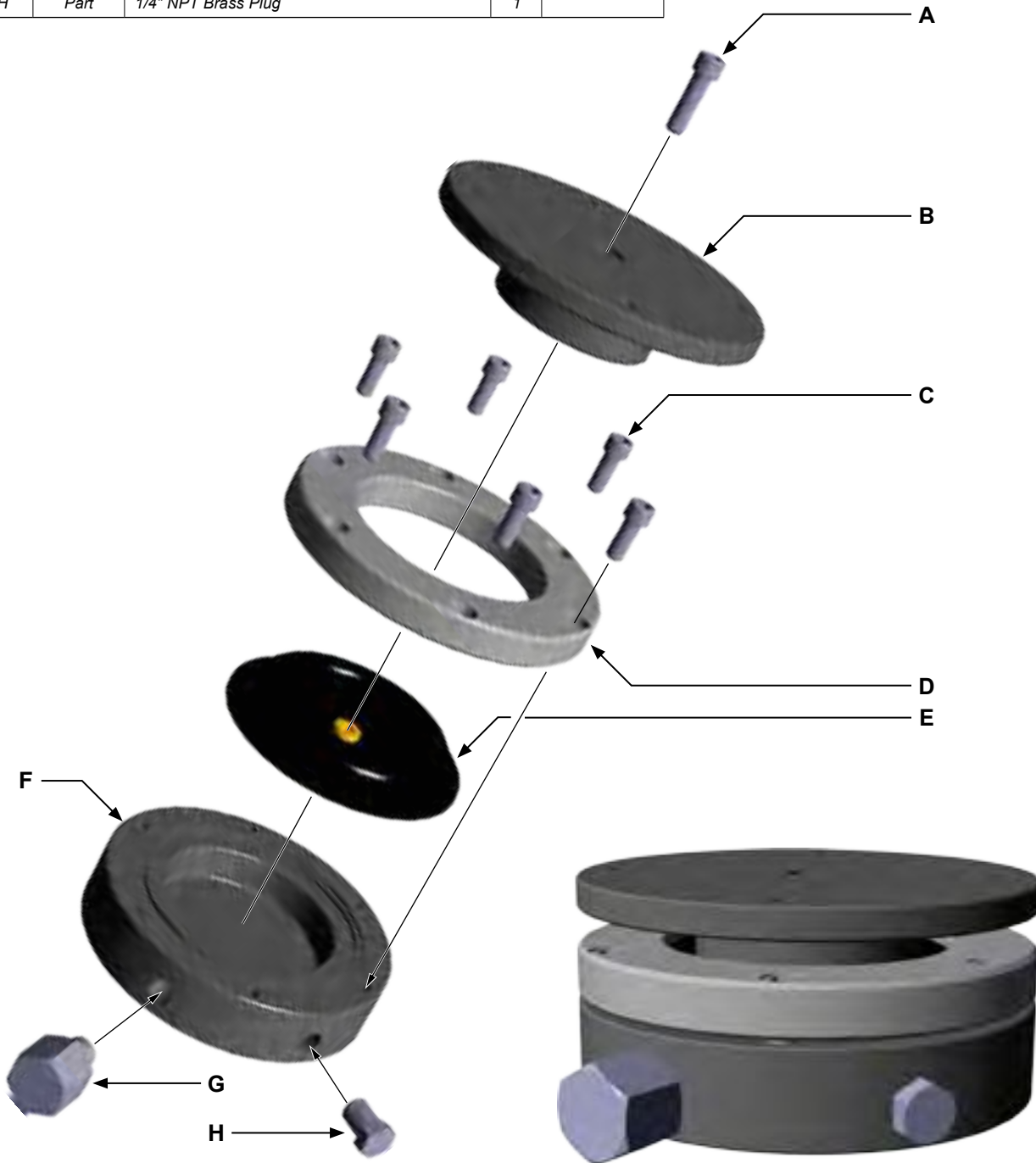
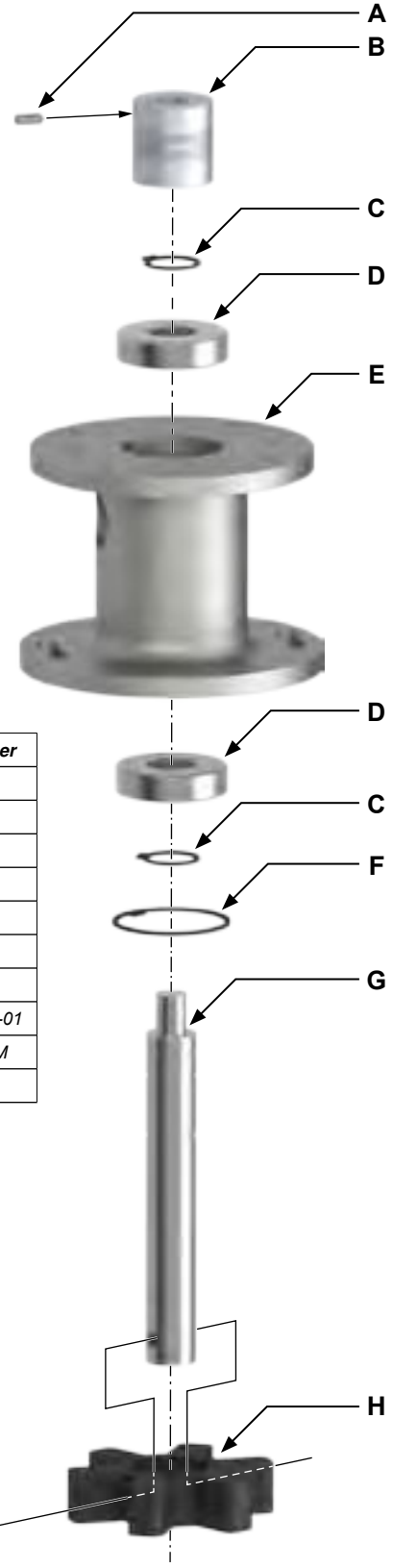

ILLUSTRATION 6.A.5: COMPRESSION LOAD CELL EXPLODED



Item	Type	Description	Qty	Part Number
	Assembly	Standard Turn Counter Encoder Mount	1	60-0001
A	Part	6-32 x 3/8" Hex Socket Head Set Screw	4	
B	Part	Helical Flexible Encoder Shaft Coupling	1	60-0130N
C	Part	Internal Retainer Ring	2	1376-13
D	Part	Bearing	2	1376-05
E	Part	Encoder Housing	1	1392-104A
F	Part	Internal Retainer Ring	1	02-0436
G	Part	Encoder Shaft	1	1392-103A-01
H	Part	Encoder Gear	1	01-0320A-M
J	Part	10-24 x 1-1/4" Hex Socket Head Set Screw	1	

ILLUSTRATION 6.A.6: TURN COUNTER ENCODER MOUNT EXPLODED

B. TROUBLESHOOTING

Under normal operating conditions, and with proper maintenance, the torque gauge and load cell system are designed to give lasting trouble-free performance. Faulty indication on the gauge will very often define a fault within the gauge.



IF TROUBLESHOOTING REVEALS THAT THERE IS INSUFFICIENT FLUID IN THE SYSTEM, BEFORE RECHARGING, CHECK THAT ALL SYSTEM COMPONENTS ARE FREE FROM DAMAGE. THIS WILL ENSURE THAT FLUID LOSS WILL NOT CONTINUE AFTER RELOADING

1. Symptom: No indication on gauge.

Possible Problem: Obstruction in hydraulic hose.

*Solutions: Check hydraulic hose for kinks.
Replace hydraulic hose.*

Possible Problem: Loss of hydraulic fluid.

Solution: Recharge hydraulic fluid (see Section 6.C). NOTE: Ensure any breaches in the hydraulic system between the load cell and torque gauge are repaired to prevent further fluid loss.

Possible Problem: Internal mechanism of torque gauge is damaged.

Solution: Replace gauge.

2. Symptom: Gauge indication unexpectedly high.

Possible Problem: Excessive hydraulic fluid.

Solutions: Completely drain hydraulic fluid from torque gauge/load cell system. Recharge following the procedure in Section 6.C.

Possible Problem: Internal mechanism of gauge is damaged.

Solution: Replace gauge.

Possible Problem: Incorrect torque gauge in use (not part of the original torque gauge/load cell pair).

Solution: Replace gauge with gauge properly calibrated for the load cell in service.

3. Symptom: Gauge indication unexpectedly low

Possible Problem: Insufficient hydraulic fluid.

Solution: Recharge hydraulic fluid (see Section 6.C). NOTE: Ensure any breaches in the hydraulic system between the load cell and torque gauge are repaired to prevent further fluid loss.

Possible Problem: Obstruction in hydraulic hose.

*Solutions: Check hydraulic hose for kinks.
Replace hydraulic hose.*

Possible Problem: Snub line not at right-angle to tong handle.

Solution: Check angle of snub line and correct if necessary.

Possible Problem: Internal mechanism of gauge is damaged.

Solution: Replace gauge.

Possible Problem: Incorrect torque gauge in use (not part of the original torque gauge/load cell pair).

Solution: Replace gauge with gauge properly calibrated for the load cell in service.

4. Symptom: Gauge indication is erratic or sluggish

Possible Problem: Insufficient hydraulic fluid in torque measurement section.

Solution: Recharge hydraulic fluid (see Section 6.C). NOTE: Ensure any breaches in the hydraulic system between the load cell and torque gauge are repaired to prevent further fluid loss.

Possible Problem: Loss of damping fluid in torque gauge.

Solution: Top up or refill damping fluid (NOTE: Ensure leakage points in gauge are identified and repaired to prevent further loss of damping fluid).

Possible Problem: Air bubbles in hydraulic fluid in the torque measurement system.

Solution: Bleed air from load cell and torque gauge and top up fluid (if necessary) as per Section 6.C.

Possible Problem: Internal mechanism of gauge is damaged.

Solution: Replace gauge.

C. PERIODIC INSPECTION AND MAINTENANCE**1. Inspection**

The torque measurement system supplied with your equipment is designed and built to provide years of trouble-free service with minimum maintenance. Periodic inspections of the load cell, hydraulic lines and fittings are recommended in order to keep the system in top operating condition. A thorough inspection should be made at each rig-up.

2. Fluid Recharge

Recharge hydraulic system with W15/16 fluid through the check valve on the torque indicating gauge. Recharging must only be performed when there is no load on the load cell. Refer to the illustrations on pages 6.3 & 6.4 for guidance if required.

- a. Place the torque indicating gauge higher than the load cell. Remove the brass 1/4" cap from the fitting on the check valve on the top of the gauge.
- b. Connect the hand pump to the check valve fitting.
- c. Elevate the load cell so it is higher than the torque gauge and hand pump.



UN-CONTAINED SPILLAGE OF THE HYDRAULIC FLUID IN THIS SYSTEM MAY CONTRAVENE GOVERNMENTAL ENVIRONMENTAL REGULATIONS, OR THE ENVIRONMENTAL REGULATIONS AND POLICIES OF YOUR COMPANY. MCCOY DRILLING & COMPLETIONS HIGHLY RECOMMENDS PLACING YOUR LOAD CELL IN A CONTAINMENT BASIN BEFORE PROCEEDING WITH THE BLEEDING & REFILLING PROCESS.

- d. Fill hand pump bowl with W15/16 hydraulic fluid.



MAINTAIN GREATER-THAN HALF FULL FLUID LEVEL IN THE HAND PUMP BOWL TO AVOID PUMPING AIR INTO THE SYSTEM. DO NOT ALLOW THE LEVEL TO FALL BELOW ONE-HALF FULL

- e. Remove the vent plug screw and Stat-O-Seal (Items C and D on Illustration 6.A.4, or item H on Illustration 6.A.5) to allow trapped air to escape.
- f. Pump fluid into the system until no more air is seen escaping from the vent port.
- g. Replace the vent plug screw and Stat-O-Seal and tighten securely.
- h. Remove load cell from containment vessel and wipe clean. Reclaim the hydraulic fluid (if it is clean) or dispose of all waste materials according to governmental or your company's proscribed environmental protection regulations.
- i. Disconnect the hand pump from the torque gauge.
- j. Replace the brass cap on the torque gauge check valve fitting.

3. Repair And Calibration

Load cell and indicator gauge should be returned to authorized repair facility for any repairs or calibration required.



***This page intentionally
left blank***



DRILLING &
COMPLETIONS

FARR

Section 7: Hydraulic Component Information

The manufacturer information contained in this section has been obtained from publicly available web sites and has been provided for information purposes only. Farr Canada Corp. does not guarantee the accuracy of the information contained in this section. All original copyrights claimed by the manufacturer(s) apply.



***This page intentionally
left blank***



POWER to be the Best!

15 series

MOTOR SELECTION GUIDE

15 Series Two Speed

Weight = 51 lbs.



- All available displacements of standard motor.
- Spool valve shift from full to partial displacement.
- Standard shift ratio is 2:1 - Some special ratios available.
- Shift on the run.
- Typical applications - winch, track and wheel drives.

Cross Section - Two Speed Motor

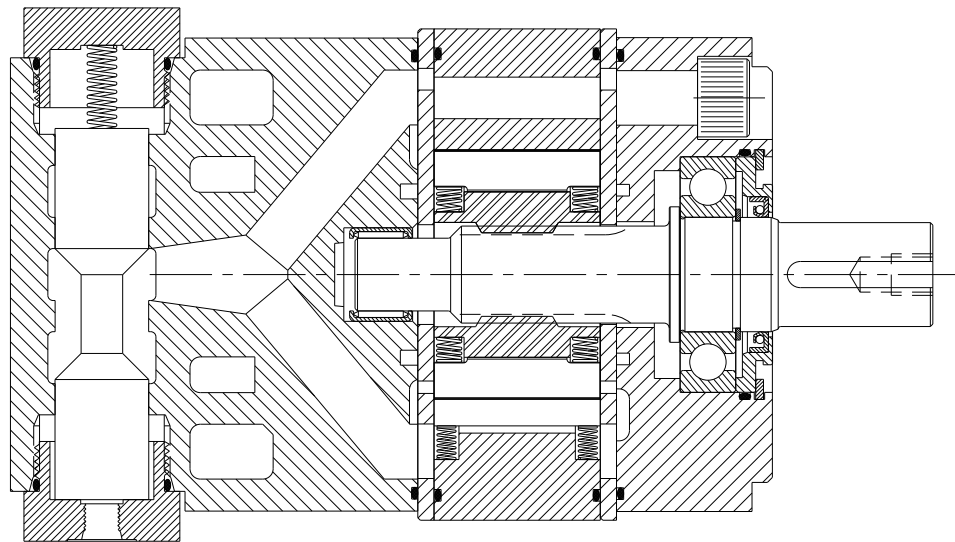

Technical Information - All Styles

VANE CROSSING VANE

The Rineer patented vane crossing vane design produces much higher volumetric and mechanical efficiencies than is possible with a standard vane type design. This design provides a sealing vane between cavities to improve mechanical and volumetric efficiencies.

STARTING AND STALL TORQUE

The Rineer motor produces torque curves which are virtually flat, with starting and stall torque equal to approximately 90-94% of theoretical torque.

MORE POWER STROKES PER REVOLUTION

The 15 Series has four stator cavities and 10 rotor vanes. Each rotor vane works in each stator cavity once per revolution, which results in 40 power strokes per revolution. This helps produce higher mechanical efficiency and flatter torque curves.

BEARING LOADING

The bearings in the 15 Series can accept radial load per the radial capacity chart. Thrust load is not recommended under most conditions. Consult with a Rineer Application Engineer for optional bearing configurations to match your application.

SEALS

Buna N seals are supplied as standard on the Rineer 15 series motors. Viton seals may be ordered as an option.

ROTATING GROUP - 1S or 1H

Under most operating conditions, 1S (standard rotating group parts) should be used. Under some high speed conditions 1H can be specified.

ROTATION

The 15 Series Motor rotates equally well in either direction and smoothly throughout its entire pressure and speed range. Looking into the end of the shaft, rotation is clockwise when oil is supplied to port "A".

HORSEPOWER LIMITATION

Maximum horsepower limitations may vary with different applications. **When using the 15 Series Motor above 75 HP, consult a Rineer Application Engineer.**

FILTRATION

25 micron minimum.

FLUID

We suggest premium grade fluids containing high quality rust, oxidation and foam inhibitors, along with anti-wear additives. For best performance, minimum viscosity should be maintained at 100 SSU or higher. Fluid temperature should not exceed 180° F. Elevated fluid temperature will adversely affect seal life while accelerating oxidation and fluid breakdown. Fire resistant fluids may be used with certain limitations. Contact Rineer for additional information.

CASE DRAIN

The 15 Series Motor is designed for either internal or external case drain. Two case drain ports are supplied. When using internal case drain, simply plug the two ports. When using external case drain, use the port at the highest elevation. We recommend case drain pressure of 35 PSI or less when using the standard seals.

CASE DRAIN CIRCULATION

Fluid should be circulated through the case when a temperature differential exists between the motor and the system in excess of 50° F. **Should this occur, contact a Rineer Application Engineer.**

MOUNTING

The mounting position is unrestricted. The shafts, pilots, and mounting faces should be within .002 TIR.

INTERMITTENT CONDITIONS

Intermittent conditions are to be less than 10% of every minute.

OTHER AVAILABLE MOTORS

For information on additional Rineer Motors, request one of the following publications:

37 Series	Publication DS371003
57 Series	Publication DS571003
125 Series	Publication DS1251003

Technical Information - Two Speed Motor

DISPLACEMENT CHANGE

When a motor is shifted from full to partial displacement the motor is changed to 50%, 35%, or 28% of its original displacement depending on its shift ratio.

STANDARD SHIFT RATIO

The standard 15 Series displacements of 15, 13, 9.5, 8, 7, and 6 CID are available in the 15 Series Two Speed with a shift ratio of 2:1. For example, a 15 CID motor shifted to partial displacement becomes a 7.5 CID motor.

SPECIAL SHIFT RATIOS

There are two special displacements available in the 15 Series Two Speed which offer higher shift ratios, the 10.5 and the 11.5 CID. The 10.5 CID motor has a shift ratio of 3.5:1, which when shifted becomes a 3 CID motor. The 11.5 CID motor has a shift ratio of 2.875:1, which when shifted becomes a 4 CID motor.

OPEN DURING CROSSOVER SPOOLS

Open during crossover spools allow port "A" to be directly connected to port "B" when the spool is shifting between full and partial displacement. Motors with -62 or -65 designations are open during crossover.

WARNING! IN SOME WINCH APPLICATIONS, OPEN DURING CROSSOVER SPOOLS (-62 or -65) ARE NOT RECOMMENDED.

CLOSED DURING CROSSOVER SPOOLS

Closed during crossover spools do not allow port "A" to be directly connected to port "B" when the spool is shifting between full and partial displacement. Motors with -63 or -67 designations are closed during crossover. These motors contain an internal factory preset relief valve. This valve protects the motor during shifting only and is not a system relief valve.

SHIFTING METHOD

Selecting between full and partial displacement is accomplished by shifting the two-position spool valve incorporated in the motor. Motors are available in either single or double pilot configurations.

SINGLE PILOT

Single pilot motors require a pilot line to be connected to port "C". When port "C" is pressurized the spool shifts the motor to partial displacement. When port "C" is vented to tank, an internal spring shifts the spool, returning the motor to full displacement.

DOUBLE PILOT

Double pilot motors require two pilot lines. One line is connected to port "C" while the other line is connected to port "D". The motor is in full displacement when port "D" is pressurized and port "C" is vented to tank. The motor is in partial displacement when port "C" is pressurized and port "D" is vented to tank.

PILOT PRESSURE

A minimum of 100 PSI over case drain pressure is required to shift the spool. The maximum allowable pressure to port "C" or "D" is 3,500 PSI.

SHIFT ON THE RUN

The 15 Series Two Speed Motor may be shifted on the run while loaded or unloaded.

MAXIMUM SPEED

Maximum rated speed is the same for either full or partial displacement as stated in the performance data.

CASE DRAIN AND CROSS PORT LEAKAGE

The combined case drain and cross port leakage of the 15 Series Two Speed Motor is approximately 1 GPM per 1,000 PSI. This will vary with the oil viscosity.

OTHER INFORMATION

All other information as specified under Technical Information also applies to the 15 Series Two Speed Motor. (See page 5)

15 Series Two Speed Envelope

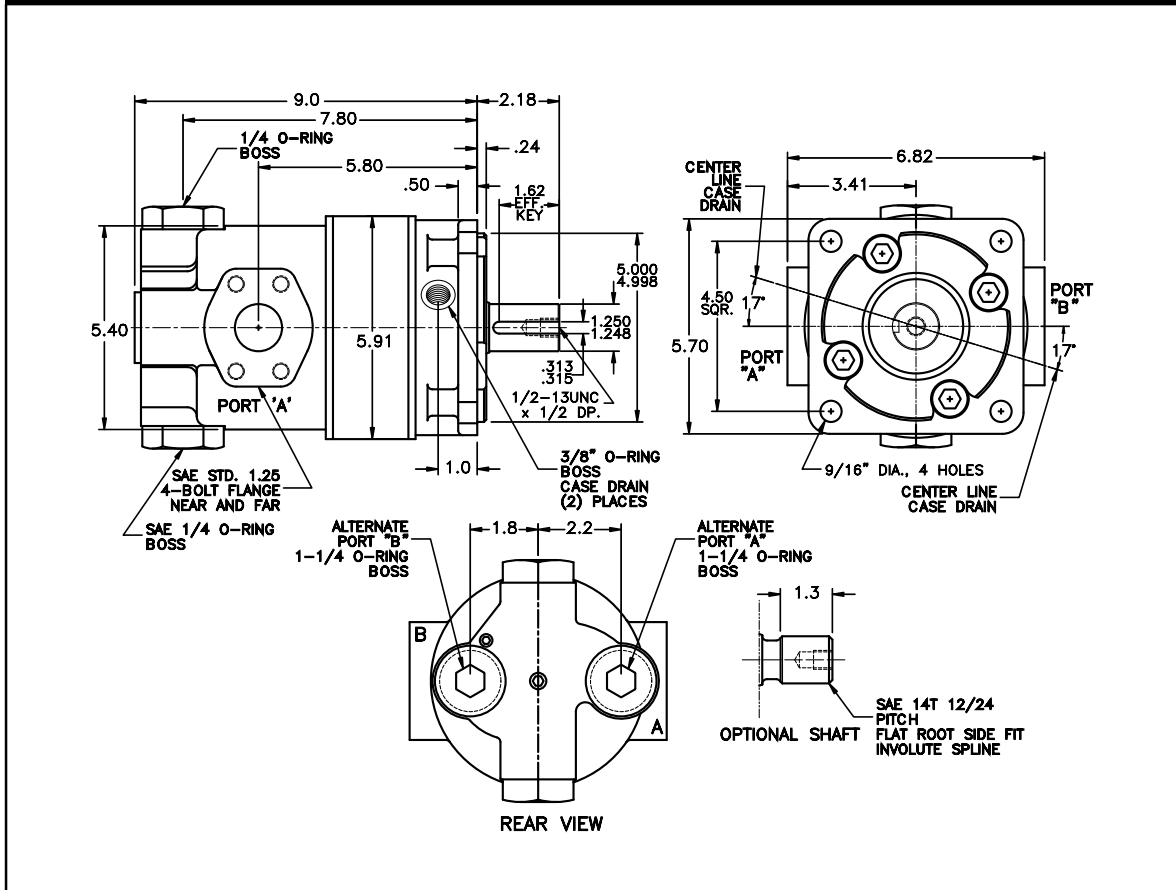

Performance Data - Selected Displacements

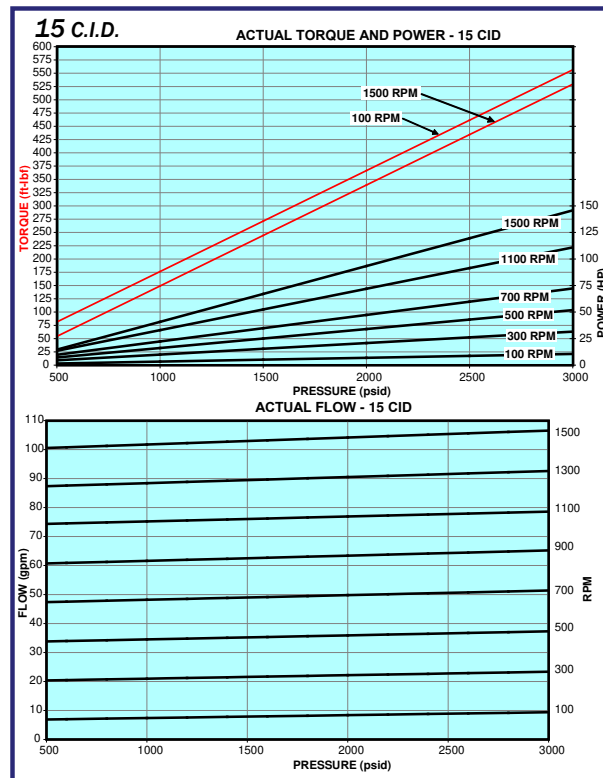
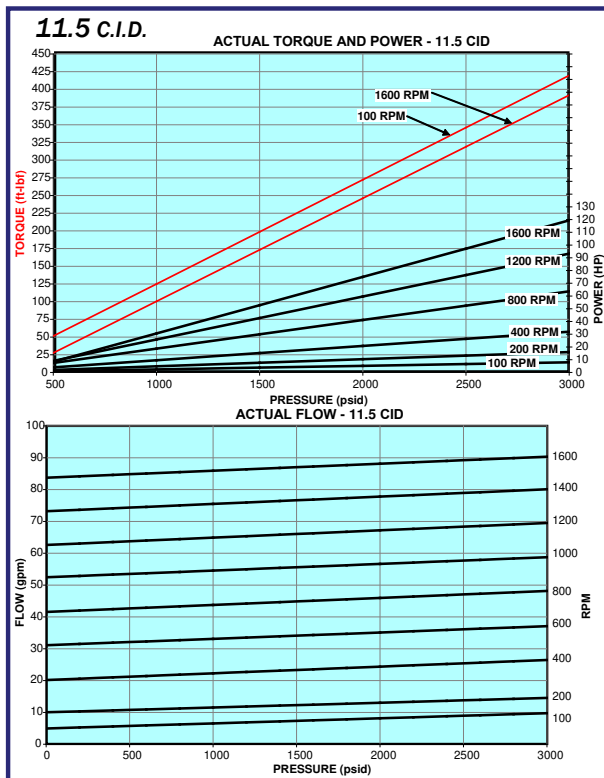
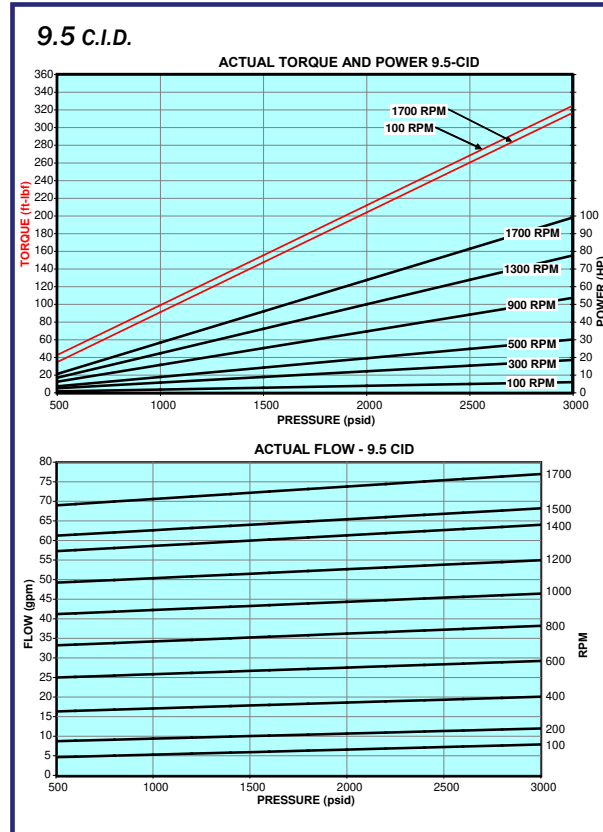
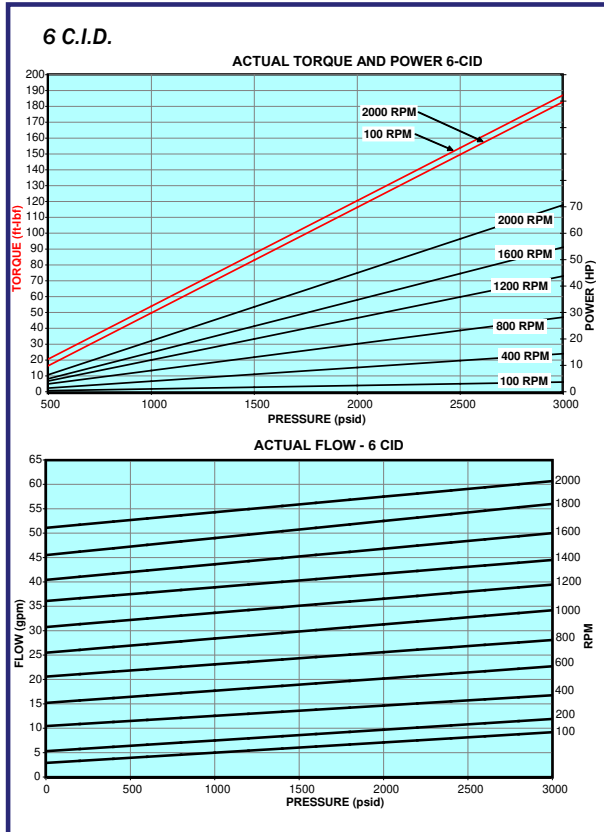

The above performance data was obtained at 140°F with ISO 46(DTE 25). These values must be maintained to obtain the performance indicated. Contact Rineer Hydraulics, Inc. for additional displacements.

Model Code

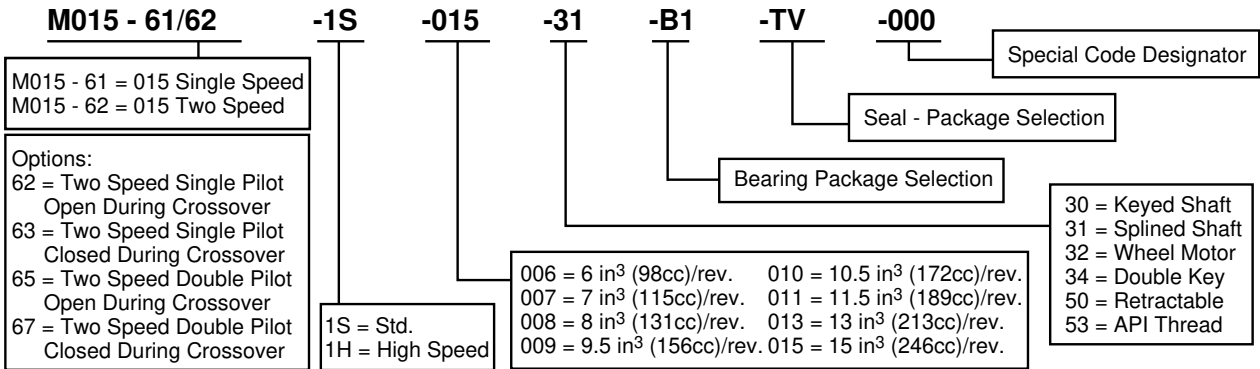

Applications





Repair Manual

15 Series



Standard Motor

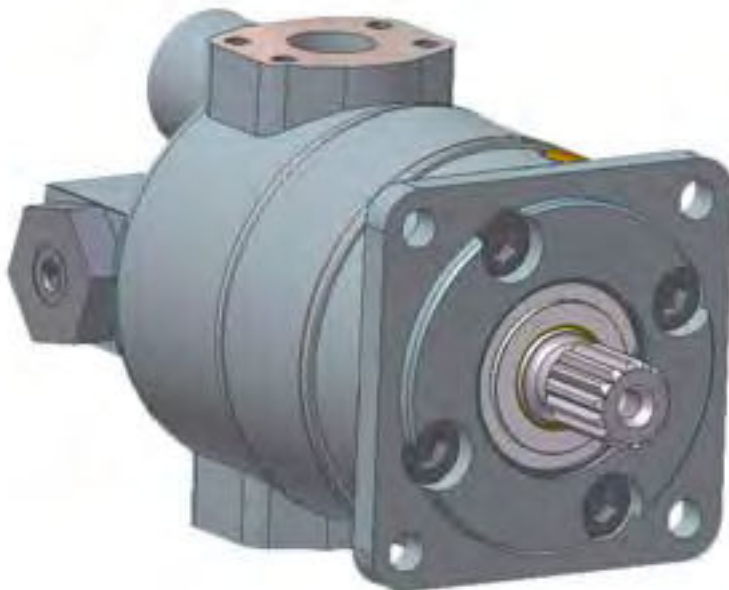

Two Speed Motor

331 BRESPOURT * SAN ANTONIO, TX 78216 * (210) 341-6333 FAX (210) 341-1231

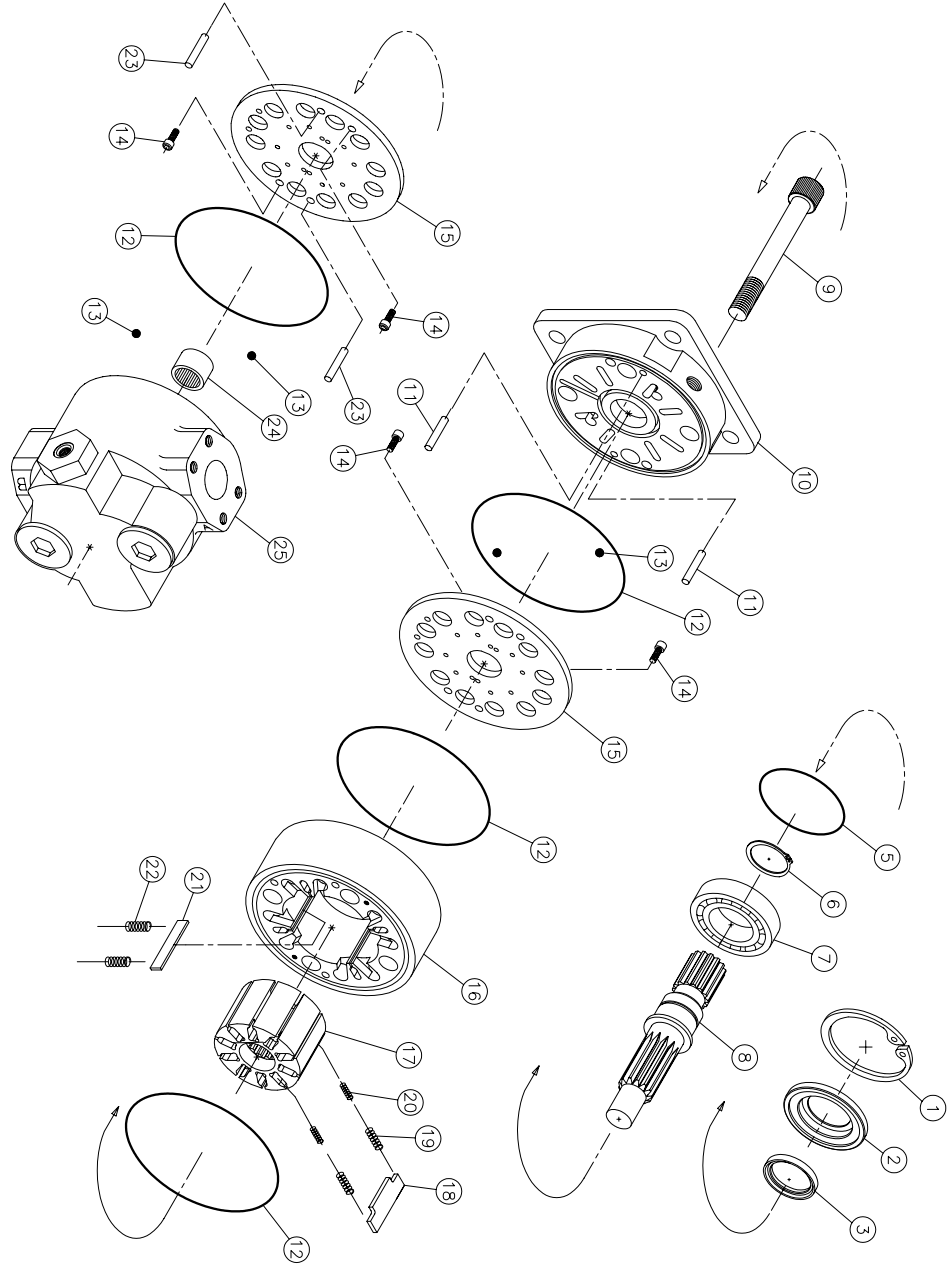

ITEM	PART NO.	DESCRIPTION	QTY
1	0150111	SEAL PLATE SNAP RING	1
2	0150135	SEAL PLATE	1
3	1250161	SEAL, SHAFT, TON	1
4		NOT USED	
5	0150114	SEAL PLATE O-RING	1
6	0150730	SNAP RINGS, BEARING	1
7	0150710	BALL BEARING	1
8	0150701	SHAFT, KEYS	1
9	0150702	SHAFT, SPLINED	1
10	0150901	BOLT	4
11	0150428	FRONT HOUSING--INTERNAL	1
12	0150610	O-RING	2
13	0150902	BALL CHECKS	4
14	0150620	PLATE SCREW	4
15	0150609	PLATE, TWO SPEED	2
16	0150401	STATOR GA 15	1
17	0150402	STATOR GA 13	1
18	0150403	STATOR GA 9.5	1
19	0150404	STATOR GA 8.0	1
20	0150407	STATOR GA 6	1
21	0150408	STATOR GA 10.5-25	1
22	0150414	STATOR GA 11.5-25	1
23	0150419	STATOR GA 5	1
24	0150300	ROTOR	1
25	0150313	ROTOR VANE	10
26	0150320	ROTOR VANE SPRING OUTER	20
27	0150321	ROTOR VANE SPRING INNER	20
28	0150410	STATOR VANE	4
29	0150420	STATOR VANE SPRING	8
30	0150429	DOWEL PINS - REAR	2
31	0150720	NEEDLE BEARING	1
32	0150841	REAR HOUSING, TS, #62	1
33	0150842	REAR HOUSING, TS, #63	1
34	0150843	REAR HOUSING, TS, #64	1

SERIES:	15	MODEL CODE:	015-62-1S-015-30 [31]-B1-TB
EXPLODED VIEW	STANDARD	TWO SPEED	
RECORD REFERENCE	DATE:	6-19-00	
DRAWN BY: JERRY W	DWG. NO:	0150044	

RINEER HYDRAULICS
CORPUS CHRISTI, TEXAS

WARNING: RINEER RECOMMENDS FOLLOWING ALL STANDARD SHOP SAFETY PRACTICES SPECIFICALLY INCLUDING WEARING OF EYE PROTECTION.

REMOVAL OF SHAFT SEAL

1



1) Remove snap ring
WARNING: Use caution when removing snap ring. If released accidentally it can become an airborne hazard.

2



1) Pry out shaft seal plate with two screw drivers.
 2) Remove seal plate o-ring from groove in bearing bore.

REMOVAL OF WHEEL MOTOR SEAL PLATE AND BEARING BOX

3



1) Loosen and remove 8 each 10-32 bolts.
 2) Pry off seal plate with screw driver.

4



Loosen and remove 8 each 3/8" bolts with 5/16" socket head wrench.

5



1) Two of the 3/8" bolt holes are provided with jack screw threads.
 2) Insert a piece of 1/4" round stock by 2-1/2" long into each jack screw hole
 3) Screw two 7/16-14 bolts into the jack screw threads until the bearing box is free of the motor.

6



Lift up on the bearing box to remove from motor.

DISASSEMBLY OF WHEEL MOTOR BEARING BOX

7



1) Loosen clamp screw in lock nut.
 2) Unscrew lock nut and remove.

8



1) Press shaft out of bearing box.
 2) Proceed to step 9, disregarding steps 11 & 12

WARNING: RINEER RECOMMENDS FOLLOWING ALL STANDARD SHOP SAFETY PRACTICES SPECIFICALLY INCLUDING WEARING OF EYE PROTECTION.

DISASSEMBLY OF FRONT HOUSING AND SHAFT

9



1) Mark one side of the motor for proper assembly, paying careful attention that the cartridge will not be installed upside down.
2) Secure the motor prior to loosening the 5/8-11 bolts.

10



1) Remove front housing
2) Note: Two 5/16" ball checks and one main body o-ring may be dislodged and fall free.

11



With the seal plate removed, press shaft and ball bearing out of front housing.

12



1) Remove snap ring from shaft.
2) Press shaft out of bearing.

DISASSEMBLY OF ROTOR/STATOR CARTRIDGE

13



Lift up rotor/stator cartridge and remove from the rear housing.

14



1) Place cartridge on any object which will hold it off the table.
2) Remove two each 10-32 place screws.
3) Remove timing plate.

15



1) Remove o-ring and springs with a small screwdriver.
2) Remove dowel pins.

16



1) Replace plate on rotor/stator cartridge.
2) Turn rotor/stator cartridge over.
3) Repeat steps 14 & 15.

WARNING: RINEER RECOMMENDS FOLLOWING ALL STANDARD SHOP SAFETY PRACTICES SPECIFICALLY INCLUDING WEARING OF EYE PROTECTION.



1) Remove the rotor.
2) Remove both the rotor and stator vanes.
3) Note: On motors manufactured prior to 1987, rotor vane slots and rotor vanes should be numbered so that vanes can be reassembled in the same vane slot.



PLATES: Normal wear results in marking of timing plates which does not impair motor performance. Replacement of the timing plate is required if any smearing, galling, or heat cracks are present.

INSPECTION AND REPLACEMENT OF PARTS



Inspect all springs and seals. We recommend replacement of all seals and springs whenever the motor has been disassembled.



ROTOR: Normal wear results in polishing of rotor faces which does not impair motor performance. Examine the rotor vane slots closely. Polishing down in the slots is normal, but if there is any indication of a "pocket" forming in the wall of the slot, the rotor should be replaced.



Inspect all parts and replace any parts which obviously show excessive wear or damage.



STATOR: Normal wear results in polishing of cam form which does not impair motor performances. Noticeable wear may be apparent along the corner of one side of the stator vane slot. This does not necessarily require replacement of the stator, but may slightly affect volumetric efficiency.

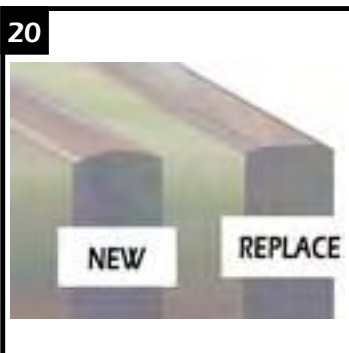

VANES: Normal wear results in slight flattening of vane tips which does not impair motor performance. Replace vane if radius is reduced by 50%. Clearance between the rotor vane and rotor vane slot varies with the vane selection. The design allows the vane to "lean" slightly in the slot, providing the required mechanical seal.



Note: Measure the rotor and stator length to the fourth decimal point and supply measurement when ordering rotor, stator, or vanes.

WARNING: RINEER RECOMMENDS FOLLOWING ALL STANDARD SHOP SAFETY PRACTICES SPECIFICALLY INCLUDING WEARING OF EYE PROTECTION.

ASSEMBLY OF ROTOR/STATOR CARTRIDGE

25



- 1) Reverse the procedures in steps 17, 16, 15, and 14
- 2) NOTE: Make sure that the radiused edge of each stator vane points to the rotor and the radiused edge of each rotor vane points to the stator.
- 3) NOTE: Make sure springs are seated in the bottom of the spring pocket in both the rotor and stator.

ASSEMBLY OF WHEEL MOTOR FRONT HOUSING

29



- 1) Reverse the procedures in steps 8 thru 3.
- 2) Screw lock nut onto shaft until all threads are engaged.
- 3) Tighten clamp screw until lock nut turns with a slight drag.
- 4) Tighten lock nut until desired rolling drag of bearing is obtained - see procedure Page 9.
- 5) Tighten clamp screw
- 6) Tighten all seal plate bolts.

ASSEMBLY OF FRONT HOUSING

26



- 1) Press bearing onto shaft.
- 2) Install snap ring.

ASSEMBLY OF MOTOR

30



- 1) Install dowel pins into rear housing.
- 2) Install ballchecks into rear housings.
- 3) Install main body o-ring.

27



- 1) Press shaft and bearing assembly into front housing by pressing on the outer race of bearing.

31



- 1) Place rotor/stator cartridge onto rear housing.
- 2) NOTE: Make sure assembly marks from step 3 are lined up.

28



- 1) Place seal in seal plate.
- 2) Place seal plate o-ring into groove in the front housing.
- 3) Press seal plate into front housing.
- 4) Install snap ring.
- 5) Proceed to step 30.

32



- 1) Install main body o-ring into front housing.
- 2) Install ball checks into front housing.
- 3) Place a small amount of grease over ball checks and o-ring.
- 4) Wipe off excess grease.

WARNING: RINEER RECOMMENDS FOLLOWING ALL STANDARD SHOP SAFETY PRACTICES SPECIFICALLY INCLUDING WEARING OF EYE PROTECTION.



- 1) Install dowel pins into rotor/stator cartridge.
- 2) Pour a small amount of clean oil into the cartridge.
- 3) Install front housing onto rotor/stator cartridge.
- 4) Make sure alignment marks are lined up.



- 1) Rotate shaft in both directions to assure that the shaft turns smoothly.
- 2) Torque motor to 190 ft./lbs.
- 3) Rotate shaft again in both directions to assure that the shaft turns smoothly.



- 1) Install 5/8-11 bolts.
- 2) Torque bolts to 50 ft./lbs.

SPOOL ASSEMBLY FOR THE TWO SPEED MOTOR

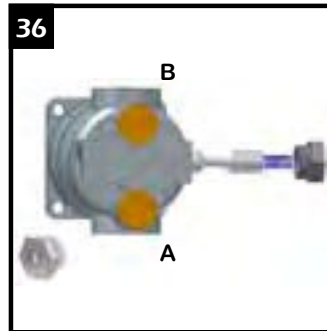

NOTE: Spool should be oriented as shown for two speed motors with model codes 62, 63, 68, & 69.

NOTE: Slight design variations may exist in motors manufactured either before or after the printing of this manual.

WHEEL MOTOR SHAFT AND BEARING ASSEMBLY PROCEDURE

- 1) Clean ALL assembly parts w/ lacquer thinner.
- 2) Dip clampnut and clamping bolt separately in lacquer thinner.
 - (Steps 3 thru 10 must be conducted to completion ONE assembly at a time.)
- 3) Press bearing cups into bearing housing. Make sure they are pressed completely against bearing shoulders.
- 4) Coat inner race of large cone with #609 (green) Loctite and press cone onto the shaft. Make sure the cone is completely against the shoulder of the shaft.
- 5) Insert shaft and large cone into bearing housing.
- 6) Coat inner race of small cone with #609 (green) Loctite and press small cone onto shaft.
- 7) Apply #272 (red) Loctite to the clampnut threads of the shaft. Apply #242 (blue) Loctite to the threads of the clamping bolt and install in the clampnut.
- 8) Spin clampnut onto shaft with the "B" face towards bearings. After the nut threads are fully engaged, but prior to the nut contacting the bearings, □
 - tighten the clamping bolt until there is drag on the clamping nut (see note Fig. 1). Tighten the nut until a 20 to 30 inch pound rolling torque is achieved.
- 9) Tighten clamping bolt on clampnut to 70 inch pounds and recheck rolling torque. Apply inspectors lacquer to head of the bolt.
- 10) Allow a minimum of 24 hrs. to dry.

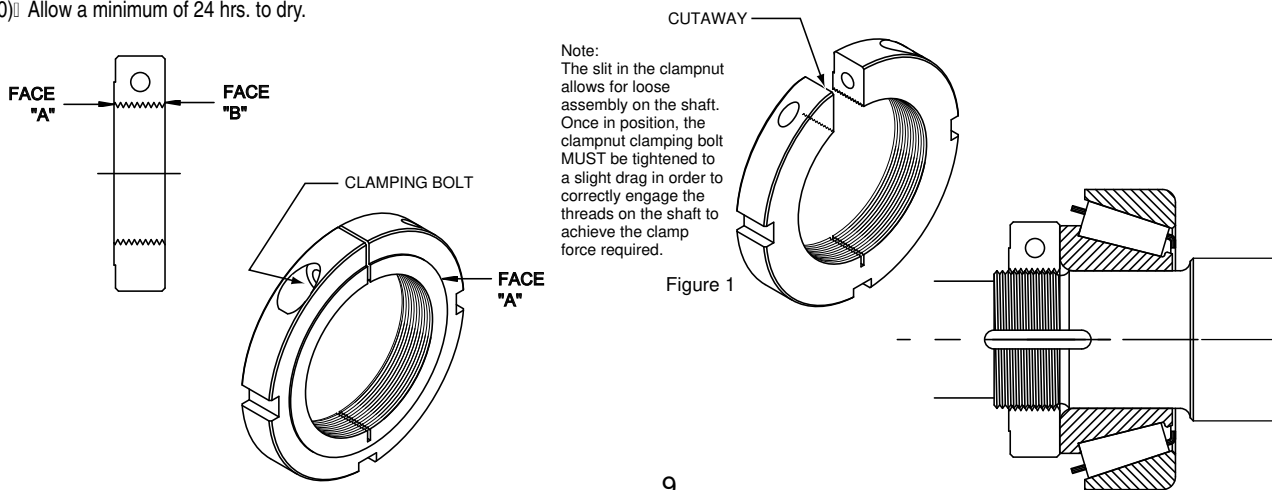

Information:

Bolt Torque -
 Main Bolts (5/8-11): 190 ft. lbs.
 Seal Plate (3/8-16)
 (Wheel Motor only): 45 ft. lbs.
 Grease used for bolt threads
 and o-ring retention:
 Pennzoil 707L RED
 Shaft seal assembly lube:
 Mobilgrease special
 with Moly

Seal Kits:
 Standard 15 series seal kit
 #0150940
 Standard 15 two speed seal kit
 #0150940
 Standard 15 wheel motor seal kit
 #0150936

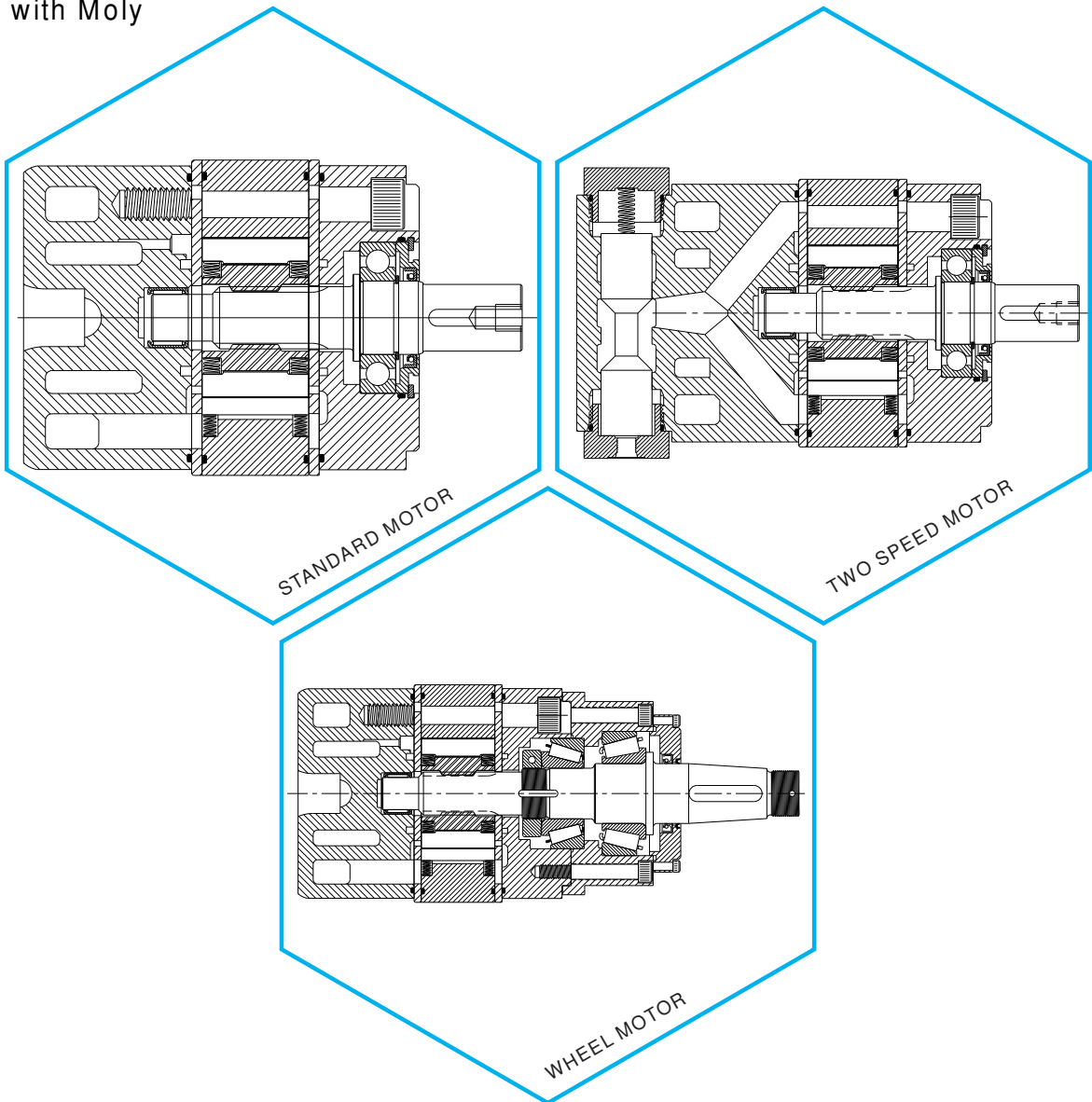

331 Breesport San Antonio, Texas 78216
 210-341-6333 Fax: 210-341-1231 e-mail: sales@rineer.com

Inlets (2500 psi) End Inlet

End Port	Top Port
1" NPT	1" NPT
SAE-16	SAE-16
SAE-20	SAE-16
NON-PORTED HOUSING	

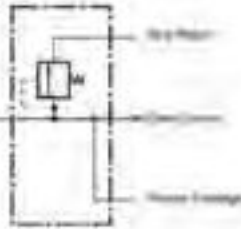

Schematic shown with Main R/V



Adjustable Relief Valve Cartridges For Inlets and Mid-section Inlets



Code	Description
DVA35-MRV-1	Main R/V pressure range 800-2100 psi. Factory set @ 1500 psi @ 50 gpm
DVA35-MRV-2	Main R/V pressure range 2001-2500 psi. Factory set @ 2500 psi @ 50 gpm
DVA35-MRVP	Main relief valve plug.

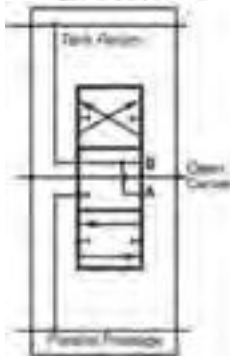

MA8
Double-Acting Section
4-Way, 3-Position, Float in Neutral Motor Spool

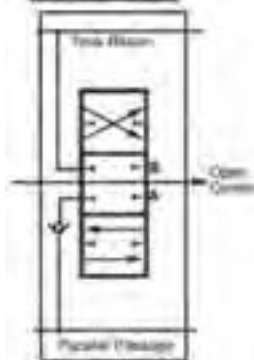

DA8
Double-Acting Section
4-Way, 3-Position, Hold in Neutral Cylinder Spool

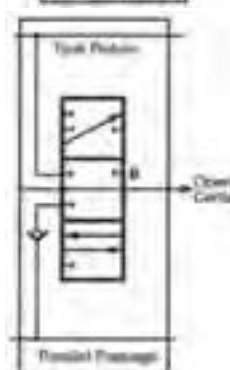

SA8
Single-Acting Section
3-Way, 3-Position, Hold in Neutral Cylinder Spool



Outlets

Tank Return Type

Code	End Port	Top Port
DVA35-TR55	1 1/4" NPT	1 1/4" NPT
DVA35-TR99	SAE-20	SAE-20
DVA35-TR00	NON-PORTED HOUSING	

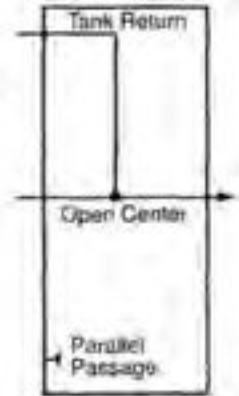

NOTE: See Section G, Page 32 for Port Plugs

Brief Circuit Descriptions

Series Circuit

Available in DVA20 sections only.

If a machine's work cycle requires simultaneous as well as separate operation of individual hydraulic work functions, a series circuit is right for the job.

As with the other circuits, the oil flows through the open center when all spools are in neutral. There is no parallel passage in standard series sections because they feed directly from the open center passage. If more than one spool is operated, pump flow goes first to the section closest to the inlet. Return flow from the last section is fed back into the open center for use by downstream sections.

Downstream sections can be series, parallel or tandem and will operate in series with the upstream section.

In series circuits, operating pressure is cumulative. Therefore, the sum of the pressures in the circuits can not exceed the circuit or main relief valve setting.

Parallel Circuits

Parallel circuits are the most common on mobile equipment because more than one function can be operated simultaneously and at random. If two or more functions are fully operated at the same time, the one with the lightest load will assert priority because the fluid will take the path of least resistance. However, the operator can divide the flow between functions by rotating the spools.

Movement of the spool meters or shuts off the flow of oil through the open center passage and pressurizes the parallel passage. Oil is then available, at the operator's discretion, to all work ports connected to the parallel passage.

Tandem Circuits

(Not available in the program)

Tandem circuits are sometimes called priority or standard circuits by other manufacturers. Tandem sections feed from the open center passage like series sections but the return flow is directed to the tank return passage and is not available downstream.

If a tandem section is followed by a series or tandem section, operating the tandem section nearest the inlet will assert priority and downstream sections will not function.

Typical Work Section Schematics

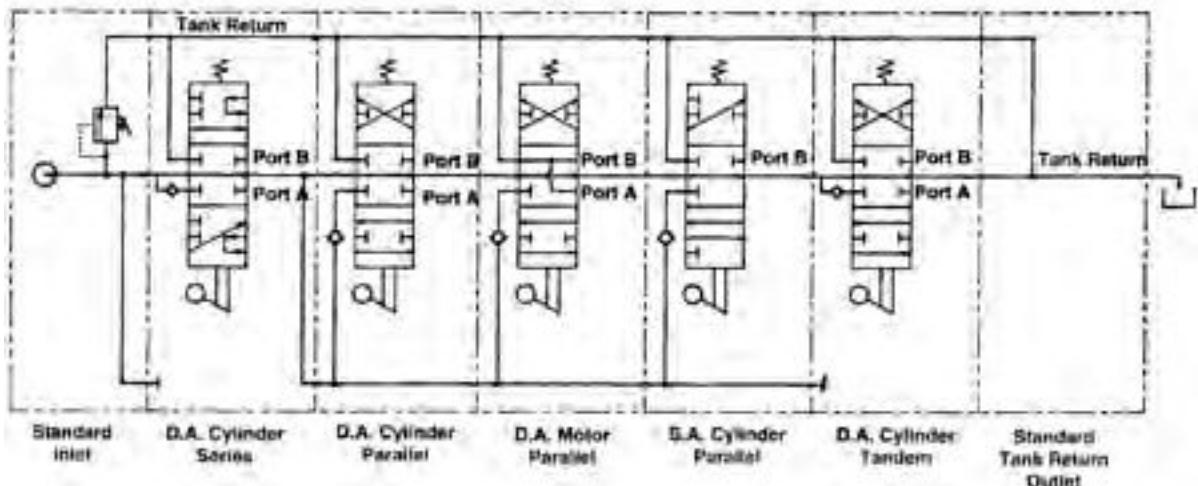

VA™/VG™ Valve Service Instructions

INTRODUCTION

This manual has been prepared to assist you in the proper maintenance of the VA20™/VA35™ and VG20™/VG35™/VG80™ directional control valves. Before any work is done, we suggest that you read the assembly and disassembly instructions completely.

The first rule of good maintenance is cleanliness, which includes a clean environment. **MAKE SURE YOU DISASSEMBLE AND ASSEMBLE YOUR HYDRAULIC EQUIPMENT IN A CLEAN AREA.** Dirt is the natural enemy of any hydraulic system.

GENERAL INFORMATION

The VA and VG model valves are updated versions of our proven A20™ and A35™ units. The VG models are cast from compacted graphite, a high strength iron alloy, which allows the valve to be rated to 3500 psi. VA models are cast from gray iron and are rated at 2500 psi. These open-center, directional-control valves are available in parallel, tandem, and series circuitry. As needed, the sectional, stack-type construction provides flexibility for the addition or subtraction of work sections to an existing valve bank. This design also permits the combination of parallel, tandem, and series circuitry in a single bank. The internal coring of each valve section determines its circuitry and the number of gasket seals required.

All sections with optional features, such as port relief valves, crossover relief valves, and anti-cavitation checks, are dimensionally larger when measured from the top of the port to the bottom of the housing. These are referred to as "hi-boy" sections. Those without work-port options can use the low-profile castings, which are called "lo-boy" sections.

REPLACEMENT PARTS

The illustrations and instructions in this manual apply only to the VA/VG series assemblies, subassemblies, and components. All valve components, except for spools and housings, are available as replacement parts or subassemblies. Spools are hone-fitted to their individual housings, so damage to either of these components means the entire section must be replaced.

We recommend that you use only genuine VA/VG series replacement parts in your service program. Manufactured to the same exacting tolerances and quality controls as the original equipment, genuine VA/VG replacement parts may help prevent premature, component failure and costly downtime. Service parts and assemblies are available through your original equipment dealer or any authorized distributor.

MAINTENANCE

Valves are often used in hazardous environments. Inspect them frequently for damage due to improper use, corrosion or normal wear. If needed, repairs should be made immediately.

Always refer to the machine manual for the proper procedure to remove the valve from the machine.

Remove the valve bank from the equipment, disconnecting all hoses, fittings, control handles and linkage connectors that might be attached to the valve. Plug all ports and thoroughly clean the exterior of the valve bank, then the port plugs can be removed.

Exploded View of Work Section

Figure 1

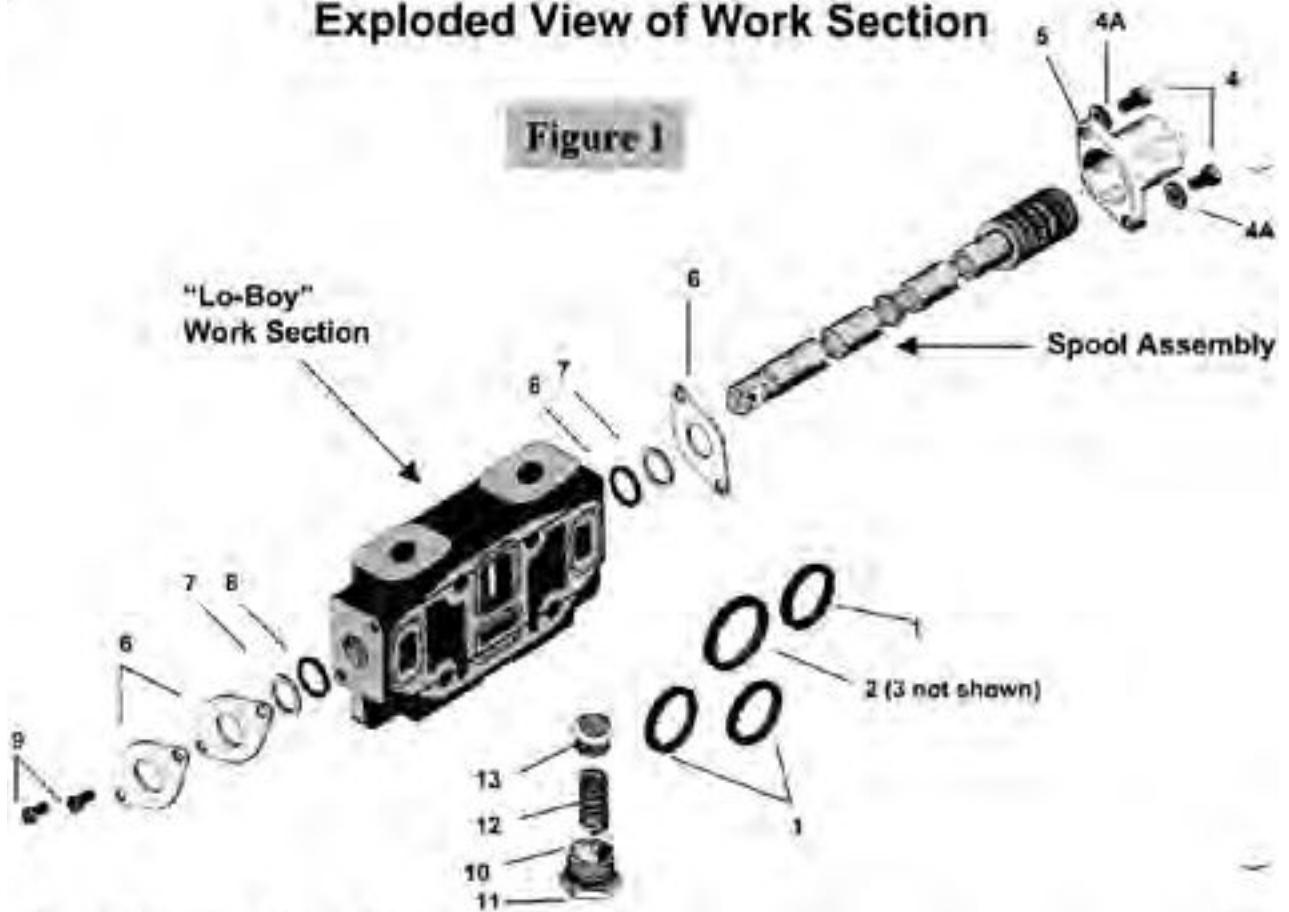

Parts List For Work Section

Item	Description	Qty.	VA/VG20 Part No.	VA/VG35 Part No.	VG80 Part No.
Parallel Section Seals* See Figure 1					
1.	Square Seals	3	391-2881-206	391-2881-200	391-2881-433
2.	Square Seal	1	391-2881-200	391-2881-403	391-2881-670
Series Section Seals					
1.	Square Seals	2	391-2881-206	391-2881-200
3.	Square Seal	1	391-2881-627	391-2881-628
Parallel and Series Section Component Parts. See Figure 1					
4.	Back Cap Screws	2	391-1433-020	391-1433-009	(4) 391-1402-068
4A.	Lock washers	8	391-3783-038
5.	Back Cap	1	341-6000-100	342-6000-100	341-0585-099
6.	Retainer Plates	3	391-2183-001	391-2183-005	391-2183-157
7.	Back up Rings	2	391-2681-378	391-2681-426	391-2681-285
8.	Spool Seals	2	391-1985-014	391-2887-212	391-2881-096
9.	Retainer Plate Screws	2	391-1433-015	391-1433-002	(4) 391-1402-015
10.	Check Valve Cap	1	391-0561-044	391-0561-044	391-0585-099
	Or Valve Cap (F.I.N.)	1	391-2251-015	391-2281-015
11.	O Ring Seal **	1	391-2881-204	391-2881-204	391-2881-249
12.	Check Spring **	1	391-3581-713	391-3581-713	391-3581-775
13.	Check Valve Poppet **	1	391-2481-069	391-2481-069	391-2383-091

*Parallel Sealing Faces includes inlets and mid-inlets.

**Not required in Float-in-neutral Sections.

Figure 2

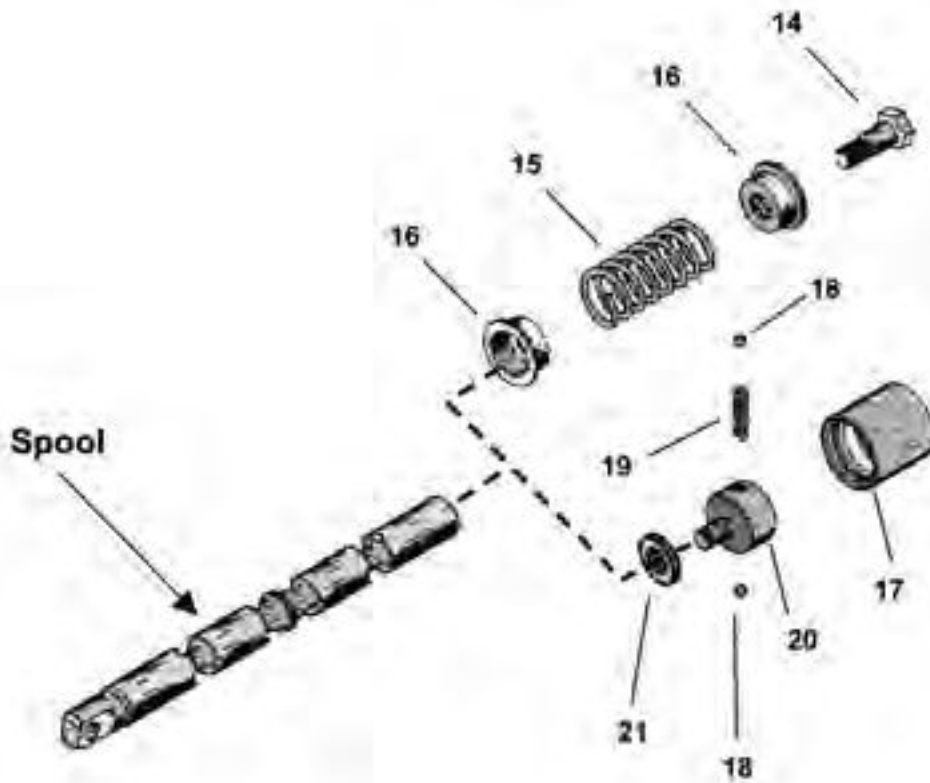

Spring Centered and Detent Spool Operators. See Figure 2

14.Stripper Bolt	1	391-1432-022	391-1432-021	391-1402-452
15.Centering Spring	1	391-3581-608	391-3581-633	391-3581-330
16.Spring Guides	2	391-1642-045	391-1642-013	391-1642-161
17.Detent Sleeve	1	391-3283-015	391-3283-008	391-3384-310
18.Detent Balls	2	391-0282-010	391-0282-009	391-0282-011
19.Detent Spring	1	391-3581-130	391-3581-015	391-3581-316
20.Detent Poppet Retainer	1	391-2583-008	391-2583-006	391-3384-311
21.Detent Spacer	1			391-3782-208

4

Valve Disassembly Instructions

Reference exploded view and parts list on page 2 and 3 for work section detail.

Step 1 - Valve Bank

This step is the most critical in the disassembly procedure. It should be followed closely to ensure that the valve bank is properly reassembled after repairs have been made.

With a waterproof, quick-drying marker, mark each casting with a sequential number. Start by marking the inlet casting with the #1 and finish by marking the outlet with the highest number.

Next, mark the port boss closest to the back cap on each work section with a "B" (for back cap end).

Then, mark the port boss closest to the spool eleva on each work section with a "C" (for eleva end).

Finally, if relief valves are removed from the valve bank they must be marked with the corresponding number of the casting and port location (B or C) from which they were removed. Inlet and mid-inlet relief valves are marked with a casting number only.

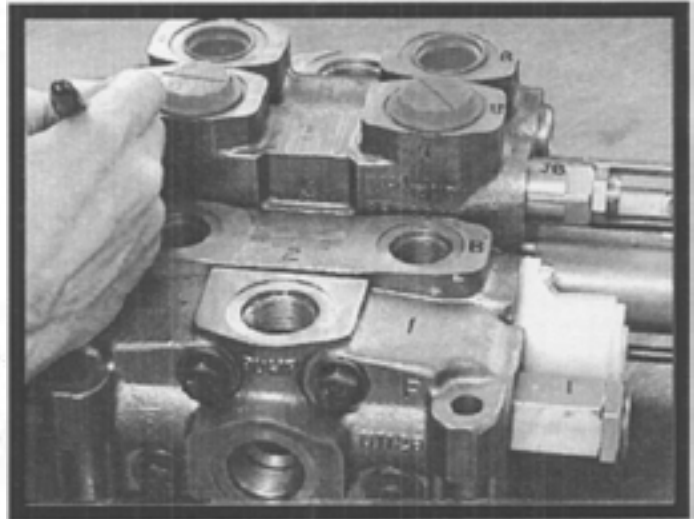

Step 2 - Tie Bolts

Remove the four, tie bolts that hold the bank together and separate the sections.

NOTE: VA valve tie bolts thread into the outlet casting. VG valve tie bolts pass through the entire bank, requiring washers and hex nuts to be fastened at both ends of the bolt.

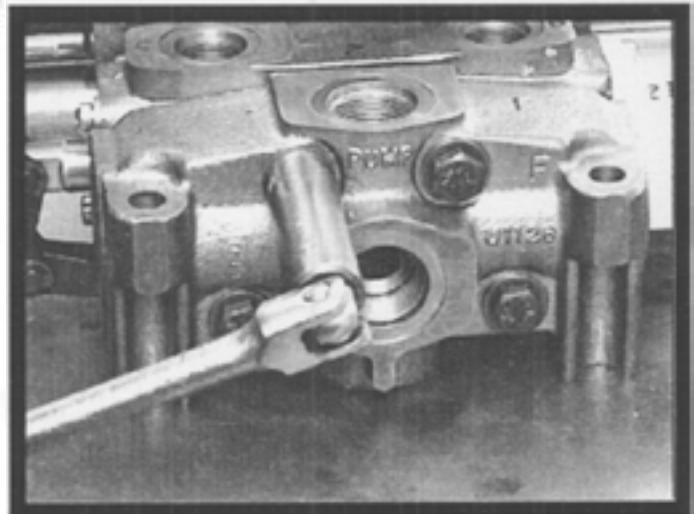

Step 3 - Section Seals

The inlet, mid-inlet and each parallel work section have four, section seals, (Fig. 1, items 1 & 2) on the downstream, mating face. Series work sections and the VA/VG35 split flow mid inlets have three section seals on the downstream mating face, (Fig. 1, items 1 & 3.) These section seals should be removed and discarded.

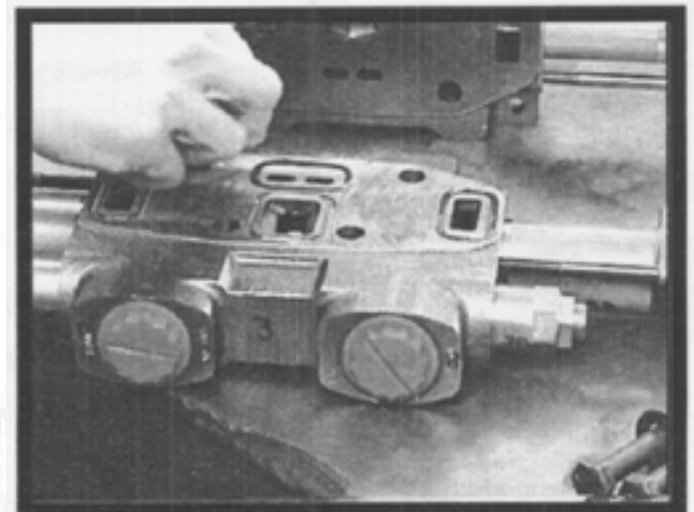

REMINDER: ALL WORK MUST BE PERFORMED IN A CLEAN AREA.

Valve Disassembly Instructions

5

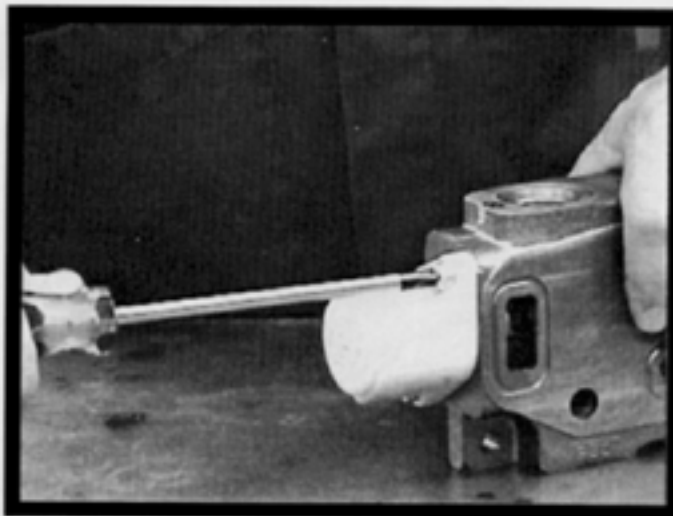

Step 4 - Valve Back Cap

Using a large, Phillips-head screwdriver, remove the two, cap screws (Fig. 1, item 4) which fasten the back cap to the work section. Lightly tap the end of the screwdriver handle with a hammer to break adhesive. Remove the back cap (Fig. 1, item 5).



Step 5 - Control Spool and Seals

Grasp the spring end of the spool with a clean, lint-free cloth and pull the spool out of the housing using a twisting motion. Generally, the rear, retainer plate (Fig. 1, item 6) back-up ring (Fig. 1, item 7) and spool seal (Fig. 1, item 8) will come out with the spool.

CAUTION: For detented spool models, be careful not to remove the detent poppet sleeve (Fig. 2, item 17) unless it is to be serviced.

Using a large, Phillips-head screwdriver, remove the two, retainer-plate screws (Fig. 1, item 9) from the spool clevis end of the work section. Lightly tap the end of the screwdriver handle with a hammer to break the adhesive. Remove the two, retainer plates (Fig. 1, item 6) the back-up ring (Fig. 1, item 7) and the spool seal (Fig. 1, item 8). Tag or mark with the appropriate, work-section identification number. (See Step 1.) Spool seals (Fig. 1, item 8) and back-up rings (Fig. 1, item 7) should be discarded.

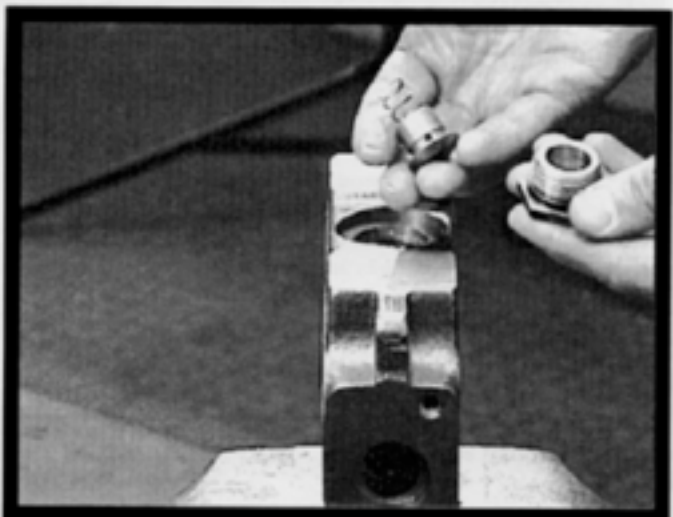

Step 6 - Transition Check

The transition check is located in the bottom center of the work section housing. Carefully clamp the work section in a vise with ports-down. Do not clamp on the machined surface. Remove the check-valve cap (Fig. 1, item 10) and its O-ring seal (Fig. 1, item 11). Discard the seal. Remove the check spring (Fig. 1, item 12) and the check-valve poppet (Fig. 1, item 13).

NOTE: Only cylinder work sections (ports blocked in neutral) have a transition check. Motor sections have only a cap plug.

6

Valve Disassembly Instructions

Spool Disassembly Spring Centered Spool

The spring assembly should not be removed from the spool unless these parts need to be replaced. Once the spool is free of the work section housing, it must be handled carefully to avoid damage. Place the spool vertically in a soft-jawed vise, clamping on the flat spool ends, and remove the stripper bolt (Fig. 1, item 14) with a wrench.

Lightly tap the stripper bolt with a hammer and a punch to help break the adhesive. Cautious application of heat may be required to free the stripper bolt, since an anaerobic thread adhesive was used during its assembly.

CAUTION: Too much heat may distort the spool.

As the stripper-bolt threads disengage, the spring (Fig. 2, item 15) and spring guides (Fig. 2, item 16) will release abruptly from the spool.

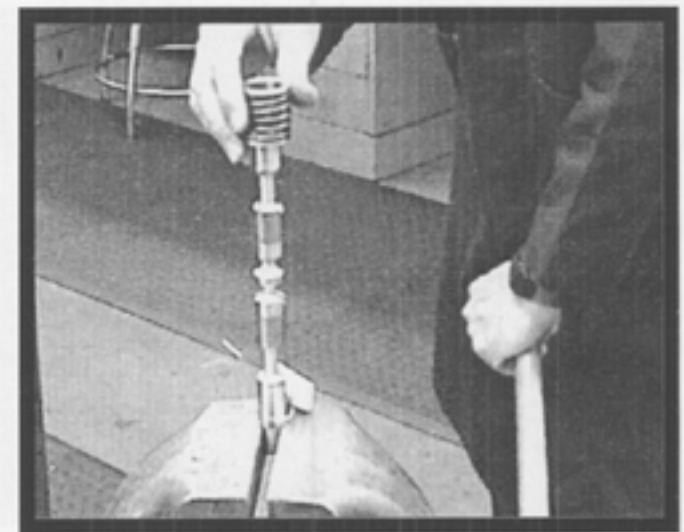

Detent Spool

The detent assembly should not be removed from the spool unless these parts need to be replaced. Wrap the detent sleeve (Fig. 2, item 17) with a clean, lint-free cloth. Grip the cloth-covered sleeve and pull firmly. As the sleeve moves back wards, the detent balls (Fig. 2, item 18) and the detent spring (Fig. 2, item 19) will release abruptly. The cloth should capture these parts and prevent their loss.

Next, clamp the spool in a soft-jawed vise and remove the detent poppet retainer (Fig. 2, item 20). Place an undersized bar through the detent ball bore to serve as a wrench. Lightly tap the detent poppet retainer with a hammer and a punch to help break the adhesive. Cautious application of heat may be required again, since an anaerobic adhesive was also used in the detent retainer assembly.

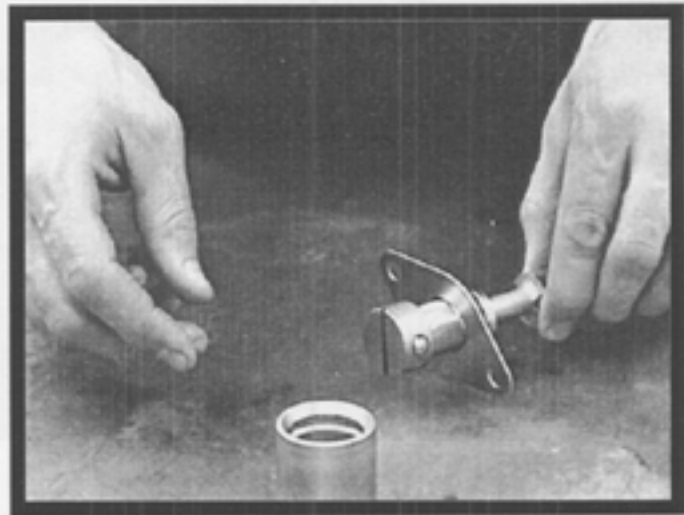

CAUTION: Too much heat may distort the spool!

CLEANING, INSPECTION, AND REPAIR

1. Inspect the spool bore, transition check seat and spool from each section for deep scratches, gouges or excessive wear. If any of these conditions exist, replace the section. Minor surface damage on the control spool and check poppet can be carefully polished away with a very fine, crocus cloth.

2. Examine the machined surfaces of the valve housing for nicks and burrs that could cause leakage between sections. Lightly stone these surfaces to remove any rough spots.

CAUTION: A shallow-milled relief area extends across the O-ring face of the valve housing. This should not be stoned or ground off!

3. Wash all parts thoroughly in a cleaning solvent and blow dry before beginning reassembly. Pay special attention to the number and letters marked on the parts in Step 1. If any marks are removed during cleaning, remark immediately.

4. Clean adhesive from threads of spool, stripper bolt, housing, cap screws and hex nut with Loctite™ (Blue) Gasket Remover.

Valve Assembly Instructions

7

Preparation of Parts

Spray the threads of the new stripper bolt (Fig. 2, item 14) tapped-threaded spool end, all screws and screw holes on both ends of the housing with LOCTITE Primer Grade NFM™ and let dry.

CAUTION: Failure to follow the recommended assembly instructions can result in poor performance or product malfunction. Product should be thoroughly tested to ensure proper operation before the valve is placed back into service.

Spring Center Spool Assembly

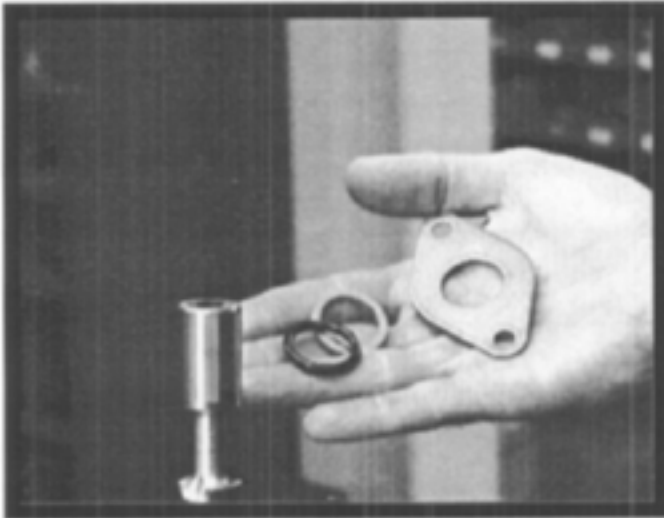

Step 1 - Spool Assembly-Spring Centered

Clamp the flat, clevis end of the control spool in a soft jawed vise. Apply Parker Super-O-Lube™ to the spool seal (Fig. 1, item 8) and slide it onto the end of the spool away from the clevis. Slide on the back-up ring (Fig. 1, item 7) and retainer plate (Fig. 1, item 6). Position these items onto the spool, so that they do not interfere with the spool operator mechanism during assembly. Do not allow the O-ring to come in contact with the sharp edge of the spool notches.

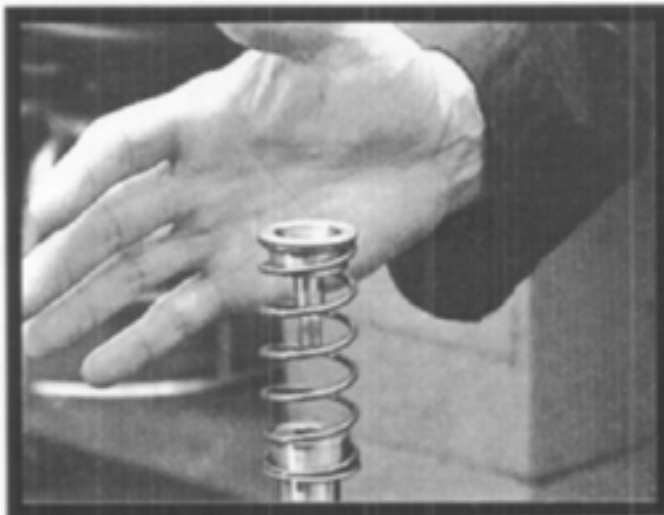

Step 2 - Attach Spring Guides and Spring

Apply 2-3 drops of Loctite 262™ or equivalent anaerobic adhesive near the middle of the female threads in the spool. Assemble the spring guides (Fig. 2, item 6) centering spring (Fig. 2, item 15) and stripper bolt (Fig. 2, item 14) onto the spool (Reverse of Step 7). Torque the stripper bolt to 175 in. lbs. +/-4 in. lbs.

CAUTION: Care must be taken to ensure that the spring retainer is not pinched under the shoulder bolt during assembly. This can result in burrs that may cause spool binding. Check for binding by compressing the spring and guides or by rotating the spring guide nearest the housing.

CAUTION: Follow the adhesive manufacturer's instructions for proper cleaning and curing. Failure to clean and prepare parts properly may result in assembly failure!

Lightly coat the centering spring with high-temperature grease to prevent rusting. Set the spool assembly aside and let it cure for a minimum of 1 hour. After curing, test the stripper bolt to make certain it can withstand 125 in. lbs. of breakaway torque.

8

Valve Assembly Instructions

Detent Spool Assembly

Step 1 - Spool Assembly-Detent

Apply Parker Super-O-Lube™ to the spool seal (Fig. 1, item 8) and slide it onto the spool. Slide the back-up ring (Fig. 1, item 7) and one retainer plate (Fig. 1, item 6) onto the spool. Position these items onto the spool, so that they do not interfere with the spool operator mechanism during assembly. Do not allow the O-ring to come in contact with the sharp edge of the spool notches. Apply 2-3 drops of Loctite 262™ or an equivalent, anaerobic adhesive near the middle of the female threads in the spool.

CAUTION: Follow the adhesive manufacturer's instructions for proper cleaning and curing. Failure to clean and prepare parts properly may result in assembly failure.



Step 2 - Spool Assembly-Detent

Thread the detent ball retainer (Fig. 2, item 20) into the spool end. Torque the detent ball retainer to 175 in. lbs. (+/-4 in lbs.). This can be accomplished by using a crow-foot socket on the flats of the clevis, and holding the spool by inserting a round, steel rod or screwdriver through the hole in the ball retainer.

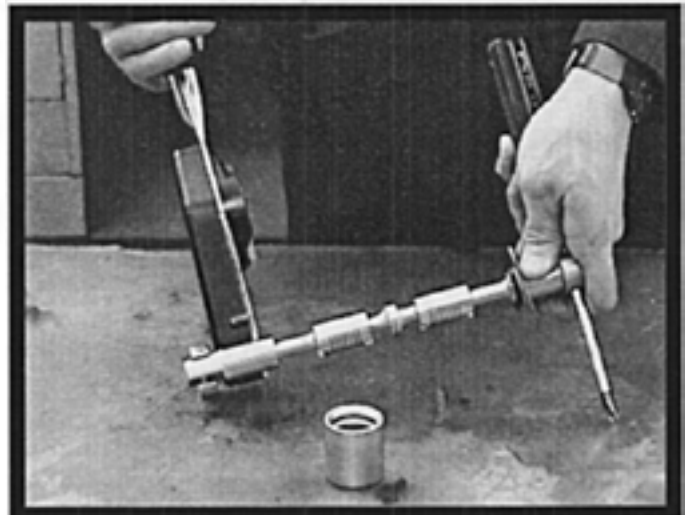

Step 3 - Detent Balls and Spring

Next, lightly coat the detent balls (Fig. 2, item 18) detent spring (Fig. 2, item 19) and entire inside diameter of the detent sleeve (Fig. 2, item 17) with high-temperature grease.

Insert the detent spring into the through hole in the detent ball retainer. Place the steel balls on the ends of the spring. Compress the balls and spring, then slip on the detent sleeve. (Note: The detent sleeve is not symmetrical, one end of the sleeve has a lead-in chamfer. This chamfer must face the spool clevis when assembled.) Move the detent sleeve to the neutral or middle position to prevent the subassembly from separating during subsequent steps.

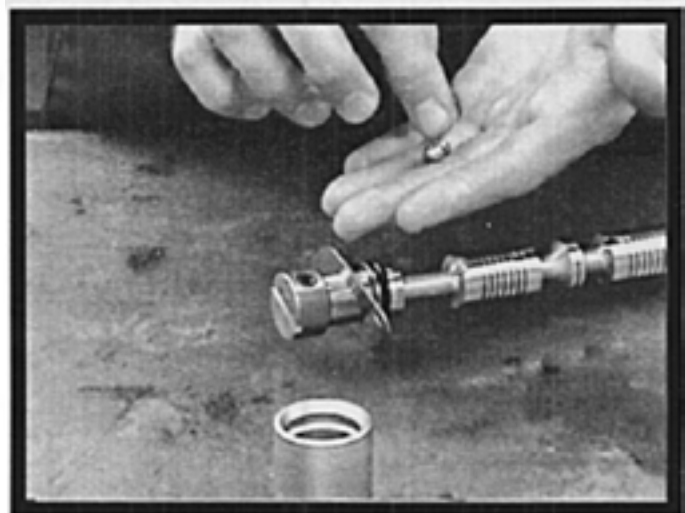

Valve Assembly Instructions

9

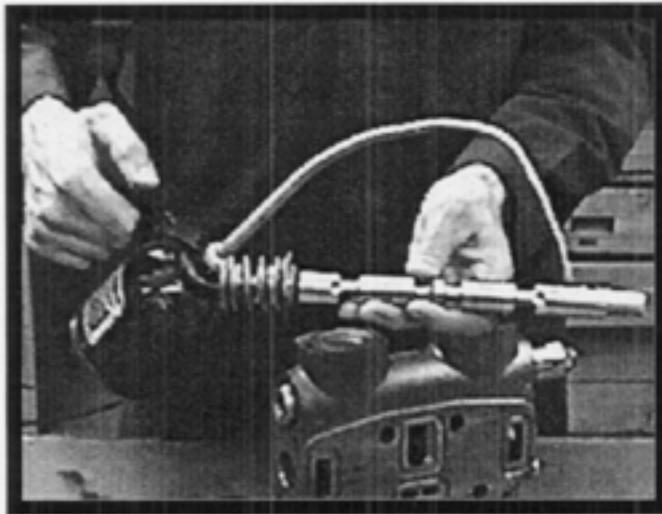

Step 1 - Spool Subassembly

Apply 2 - 3 drops of Lactac 262™ or equivalent to the fillister screw holes on both ends of the housing.

Apply a light coating of clean hydraulic oil to the valve spool. Carefully insert the spool assembly into the housing. Use caution to avoid causing burrs. Be careful not to pinch, roll or damage the seals. Make sure that the spool and housing are in the proper orientation (see Step 1, page 6 disassembly).

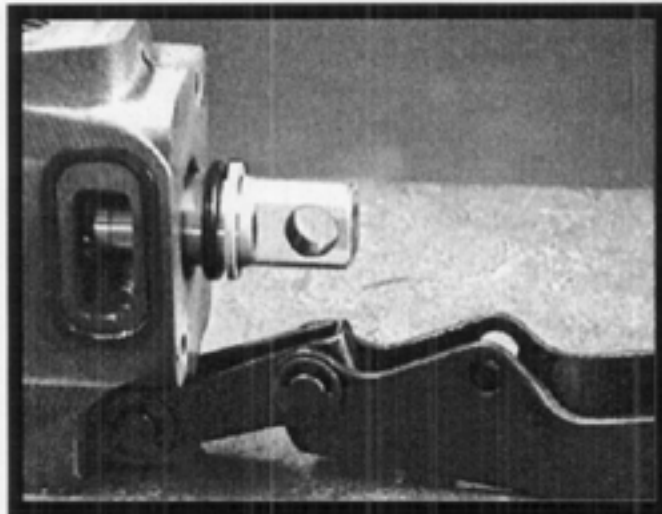

Step 2 - Spool Seal and Back up

Apply Parker Super-Q-Lube™ to the spool seal (Fig. 1, item 8) and slide it onto the spool. Slide on the back-up ring (Fig. 1, item 7). Push both items into the counter-bore until they bottom out.

Assemble the two, front, retainer plates (Fig. 1, item 6) using the two short, fillister screws (Fig. 1, item 9). Check retainer plates for proper alignment. Tighten to a final torque of 34 in. lbs. \pm 2 in. lbs.

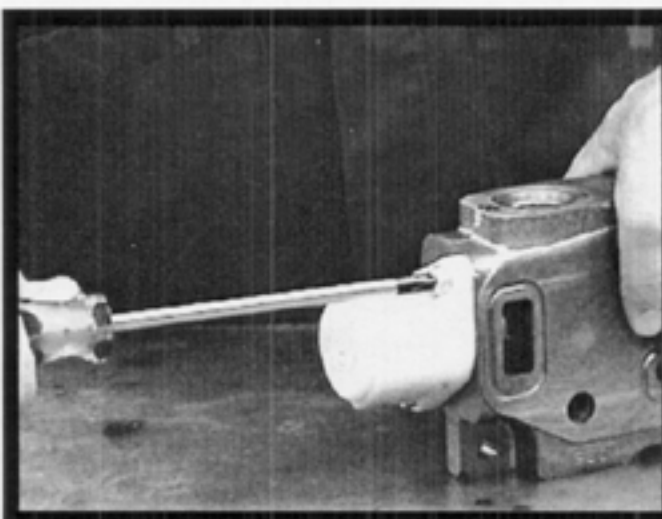

Step 3 - Back cap

Install the back cap using the two, long, fillister screws (Fig. 1, item 4). Tighten to a final torque of 34 in. lbs. \pm 2 in. lbs.

Caution: Excessive torque will damage the back cap ears!

10

Valve Assembly Instructions

Step 4 - Install Transition Check

Inspect transition check components for cleanliness. Install check poppet (Fig. 1, item 13) into the transition check cavity. Align the check spring (Fig. 1, item 12) square to the poppet, then carefully place the check cap (Fig. 1, item 11) over the poppet and spring. Turning by hand, engage several threads. Tighten to a final torque of 75 (U. lbs. - 1/-4) lbf.

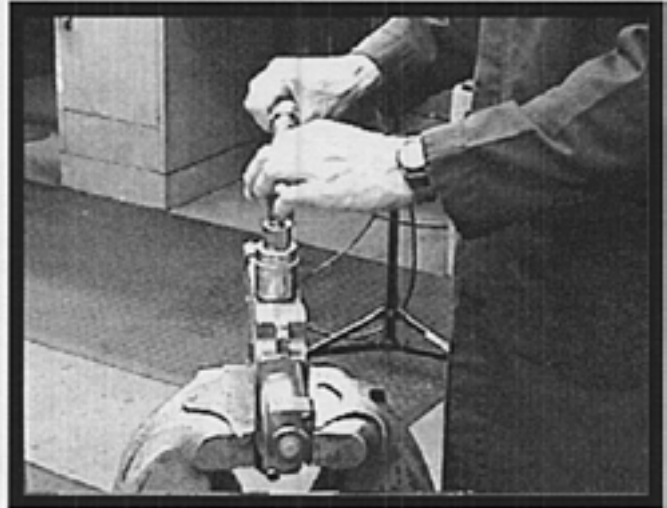

Step 5 - Relief Valves

Return all relief valves to their proper positions and torque to 75 ft. lbs.

Install new section seals. Place section seals (Fig. 1, items 1 & 2, or items 1 & 3) in the proper grooves. Make certain seals stay in their grooves during assembly.

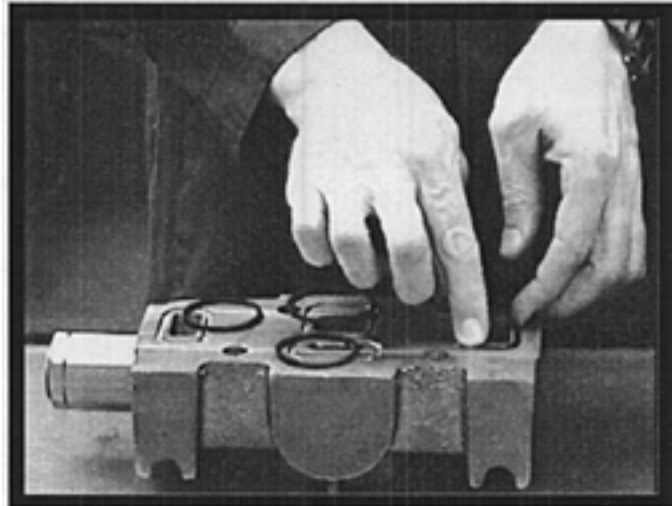

Step 6 - Install Tie Bolts

Slide the tie bolts through the inlet casting. If cap screws are used, place a washer on the cap screw prior to installation. Place the valve sections on the tie bolts in their proper sequence (see Step 1, page 4). Turning by hand, engage several threads in the nut. If it is a VG series assembly, assemble nut and washer to either end of the stud and follow above instructions. Torque the tie bolts in a cross-corner pattern.



Tie Bolt Torque Values

- VA20 - 29 ft. lbs. (348 in. lbs.)
- VG20 - 42 ft. lbs. (504 in. lbs.)
- VA35 - 34 ft. lbs. (408 in. lbs.)
- VG35 - 75 ft. lbs. (900 in. lbs.)
- VG80 - 150 ft. lbs. (1800 in. lbs.)

28	Troubleshooting	
TROUBLE	PROBABLE CAUSE	REMEDY
Oil leaks between sections	Pinched, blown or missing section seal	Replace section seal
	Stud fasteners not correctly torqued	Replace section seals and re-torque
	Mounting plate not level	Loosen mounting bolts and shim as required
	Contamination/burrs on seal	Clean seal groove, replace section seal
Oil leaks at either end of spool	Over-pressurized tank core	Correct high, back-pressure condition
	Worn or damaged spool seals	Replace seals and seal retainers
Spring - centered spools do not return to neutral	Broken centering spring	Replace centering spring
	Misalignment of operating linkage	Check linkage for mechanical binding
	Foreign particles in system	Clean valve and system
Load will not hold	Cylinder leaking or worn	Check cylinder - repair
	Port relief valve not holding	Remove and clean or replace
	Spool or housing scored or worn excessively	Replace section
Load drops when spool moved from neutral	Dirt or foreign particles lodged between check-valve poppet and seat	Disassemble, clean & reassemble
	Scored or sticking check-valve poppet	Replace poppet
No motion, slow, or erratic system operation	Worn pump	Check flow & pressure
	Defective cylinder or motor	Repair or replace
	Low-reservoir oil level	Add oil to specifications
	Clogged suction strainer	Clean or replace
	Suction line restricted	Check lines
	Relief valve not properly set	Check pressure setting
	Relief valve poppet or seat scored & sticking open	Replace relief valve
Valve spool not shifted to full stroke	Check spool linkage travel	

Pilot-to-open check valve with standard pilot

Capacity:

30

gpm (120 L/ min.)

Functional Group:

Products : Cartridges : Pilot-to-Open Check Valve : 3-Port, Non-Vented : Standard Pilot, Steel Seat

Model:

CKEB

Product Description

This valve is a pilot to open check valve. It has a non-sealed pilot, a steel seat, and is non-vented. It allows free flow from the valve (port 2) to the load (port 1) and blocks flow in the opposite direction. Pressure at the pilot (port 3) will open the valve from port 1 to port 2. Pilot pressure needed at port 3 to open the valve is directly proportional to the load pressure at port 1. Pressure at port 2 directly opposes pilot pressure.

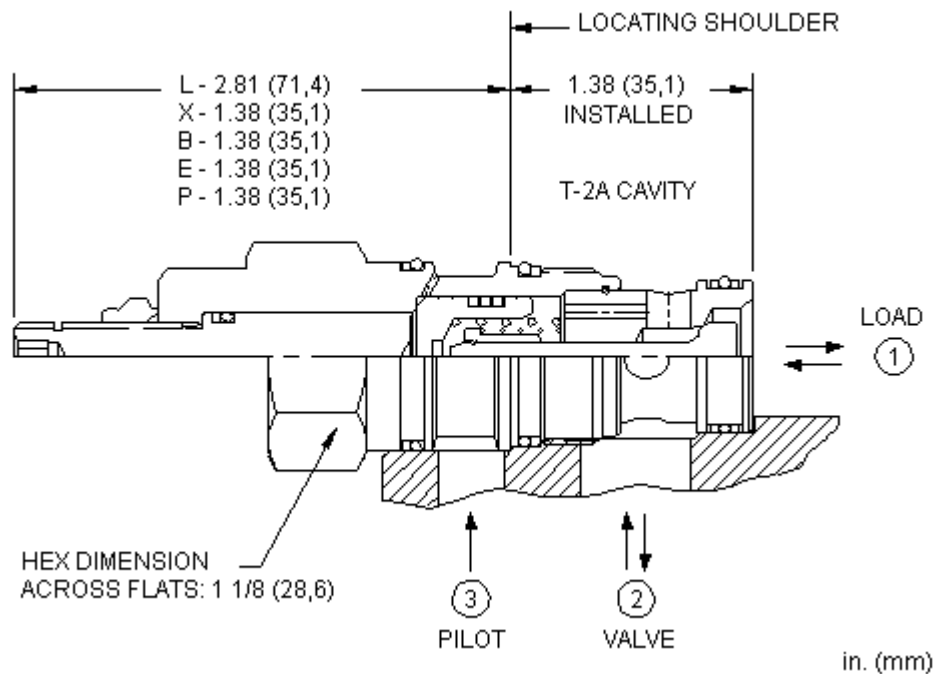
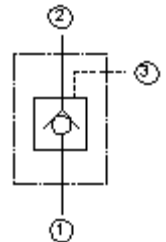

Technical Features

- Provides hose break protection, prevents loads from drifting and positively locks pressurized loads.
- Extremely low leakage. The seat and poppet are heat treated for long life. If the load drifts due to the valve, the seat has probably been damaged by contamination and the valve should be replaced.
- Pilot-to-open check cartridges are locking valves, not motion control valves. For motion control applications,
- Standard unsealed pilot allows air trapped in the pilot line to be purged from the circuit.
- Optional external porting out of the hex end of the cartridge is available for external piloting. In this configuration, port 3 is blocked. See Control options E, and P.
- This 3 port pilot-to-open check valve and 3 port counterbalance valves are physically interchangeable (i.e. same

use counterbalance valves.

- Stainless steel cartridge options P or W are intended for use within corrosive environments with all external components manufactured in stainless steel or titanium. Internal working components remain the same as the standard valves.

cavities, same flow path for a given frame size). However, cartridge extension dimensions from the mounting surface may vary.

- Incorporates the Sun floating style construction to eliminate the effects of internal parts binding due to excessive installation torque and/or cavity/cartridge machining variations.

Technical Data

	U.S. Units	Metric Units
Cavity	T-2A	
Capacity	30 gpm	120 L/min.
Pilot Ratio	3:1	3:1
Maximum Operating Pressure	5000 psi	350 bar
Maximum Valve Leakage at 110 SUS (24 cSt)	1 drops/min.	0,07 cc/min.
Series (from Cavity)	2	
Valve Hex Size	1 1/8 in.	28,6 mm
Valve Installation Torque	45 - 50 lbf ft	60 - 70 Nm
Model Weight	.50 lb	0,25 kg
Seal Kits	Buna: 990-202-007	
Seal Kits	Viton: 990-202-006	

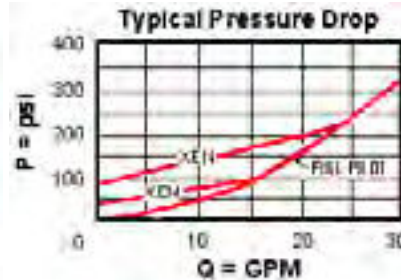
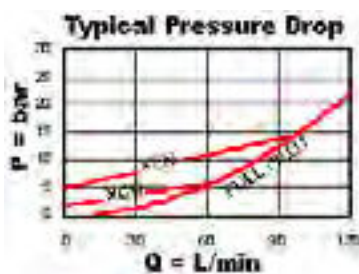

Option Selection

CKEB-X C N

Preferred Options

Control

X Standard Pilot

Standard Options

L Manual Load Release

Cracking Pressure

C 30 psi (2 bar)

A 4 psi (0,3 bar)

B 15 psi (1 bar)

D 50 psi (3,5 bar)

E 75 psi (5 bar)

F 100 psi (7 bar)

External Material/Seal Material

N Buna-N

P Stainless/Buna-N

V Viton

W Stainless/Viton

Pilot-to-open, spring biased closed, unbalanced poppet logic element

Capacity:
60 gpm (240 L/ min.)

Functional Group:

Products : Cartridges : Corrosion Resistant : Logic Element : Unbalanced Poppet, Pilot-to-open, Switching Element, Spring biased closed, External Pilot Port 3 pilot source

Model:
LKHC

Product Description

These unbalanced poppet, logic valves are 2-way switching elements that are spring-biased closed. Pressure at either work port 1 or 2 will further bias the valve to the closed position while pressure at port 3 will tend to open it. The force generated at port 3 must be greater than the sum of the forces acting at port 1 and port 2 plus the spring force for the valve to open. NOTE: The pilot area (port 3) is 1.8 times the area at port 1 and 2.25 times the area at port 2.

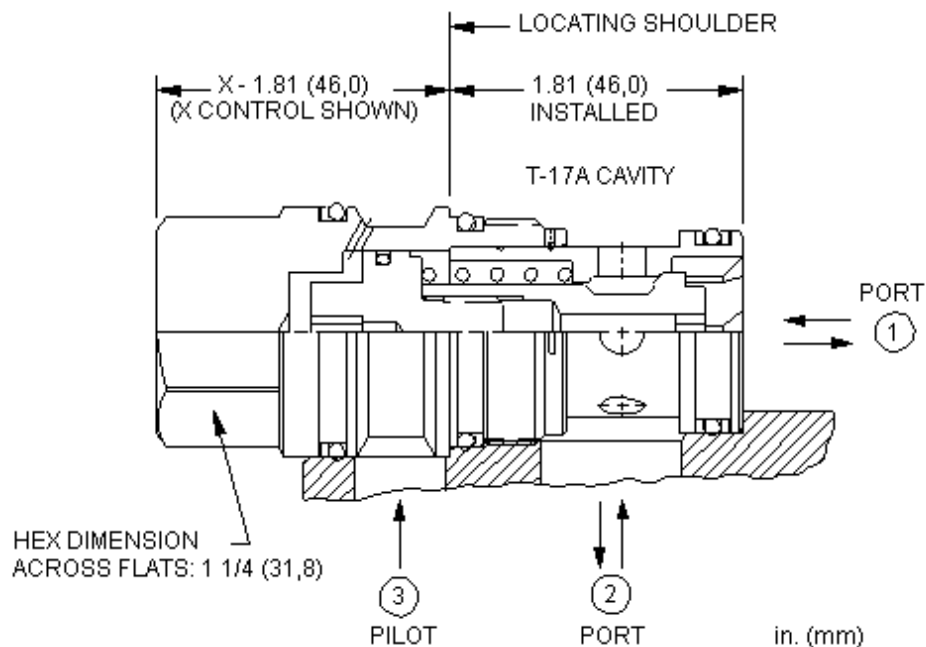
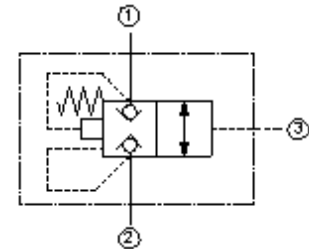

Technical Features

- Because these valves are unbalanced, operation is pressure dependent. Opening and closing of the poppet are functions of the force balances on three areas: 1) Port 1 = 100%, Port 2 = 80%, and Port 3 = 180%.
- These valves are pressure responsive at all three ports, therefore it is essential to consider all aspects of system operation through a complete cycle. Pressure changes at any one port may cause a valve to switch from a closed to an open position, or vice versa. All possible pressure changes in the complete circuit must be considered to assure a safe, functional system design.

- These valves have positive seals between port 3 and port 2.
- Incorporates the Sun floating style construction to eliminate the effects of internal parts binding due to excessive installation torque and/or cavity/cartridge machining variations.
- Stainless steel cartridge options P or W are intended for use within corrosive environments with all external components manufactured in stainless steel or titanium. Internal working components remain the same as the standard valves.

Technical Data

	U.S. Units	Metric Units
	T-17A	
Cavity		
Capacity	60	240 L/min.
Area Ratio, A3 to A1	1.8:1	
Area Ratio, A3 to A2	2.25:1	
Maximum Operating Pressure	5000	350 bar
Maximum Valve Leakage at 110 SUS (24 cSt)	10	10 drops/min.@70 bar
Pilot Volume Displacement	.15	2,5 cc
Series (from Cavity)	3	
U.S. Patent #	4,795,129	
Valve Hex Size	1 1/4	31,8 mm
Valve Installation Torque	150 - 160	200 - 215 Nm
Seal Kits	Buna: 990-017-007	
Seal Kits	Viton: 990-017-006	

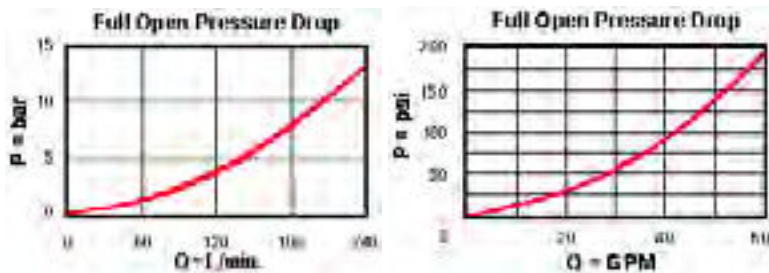

Option Selection

LKHC-X D N



Preferred Options

Control

Cracking Pressure

External Material/Seal Material

Standard Options

X Not Adjustable

N Buna-N
V Viton

Pilot operated, balanced piston relief valve

Capacity:
12 gpm (45 L/ min.)

Functional Group:
Products : Cartridges : Relief : 2 Port : Pilot Operated, Balanced Piston

Model:
RPCC-KAN

Product Description

Pilot-operated, balanced-piston relief cartridges are normally closed pressure regulating valves. When the pressure at the inlet (port 1) reaches the valve setting, the valve starts to open to tank (port 2), throttling flow to regulate the pressure. These valves are accurate, have low pressure rise vs. flow, they are smooth and quiet, and are moderately fast.

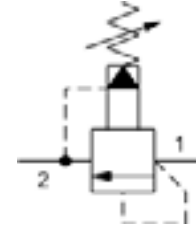

Download

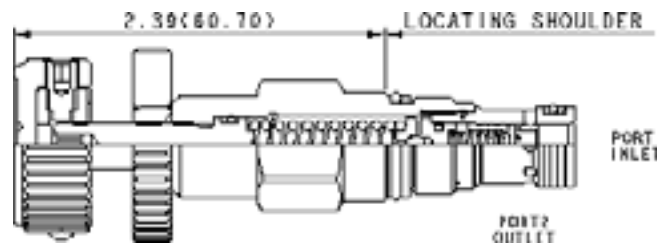

Technical Features

- Will accept maximum pressure at port 2; suitable for use in cross port relief circuits. If used in cross port relief circuits, consider spool leakage.
- Minimum setting is 75 psi (5 bar) for all spring ranges.
- Not suitable for use in load holding applications due to spool leakage.
- Back pressure on the tank port (port 2) is directly additive to the valve setting at a 1:1 ratio.
- The main stage orifice is protected against contamination.
- All 2-port relief cartridges (except pilot reliefs) are physically and functionally interchangeable (same flow path, same cavity for a given frame size).
- Incorporates the Sun floating style construction to minimize the possibility of internal parts binding due to excessive installation torque and/or cavity/cartridge machining variations.

Technical Data

	U.S. Units	Metric Units
Cavity		T-162A
Capacity	12 gpm	45 L/min.
Adjustment - Number of Clockwise Turns to Increase Setting		5
Factory Pressure Settings Established at	4 gpm	15 L/min.
Maximum Operating Pressure	5000 psi	350 bar
Maximum Valve Leakage at 110 SUS (24 cSt)	2 in ³ /min.@1000 psi	30 cc/min.@70 bar
Response Time - Typical		10 ms
Series (from Cavity)		Series 0
Valve Hex Size	3/4 in.	19,1 mm
Valve Installation Torque	25 - 30 lbf ft	35 - 40 Nm
Adjustment Screw Internal Hex Size	5/32 in.	4 mm
Adjustment Nut Hex Size	9/16 in.	15 mm
Adjustment Nut Torque	108 lbf in.	12 Nm
Model Weight	0.30 lb.	0.14 kg.
Seal Kits - Cartridge		Buna: 990-162-007
Seal Kits - Cartridge		Viton: 990-162-006

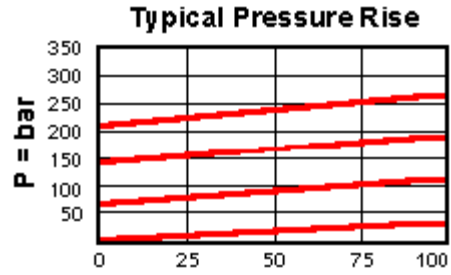
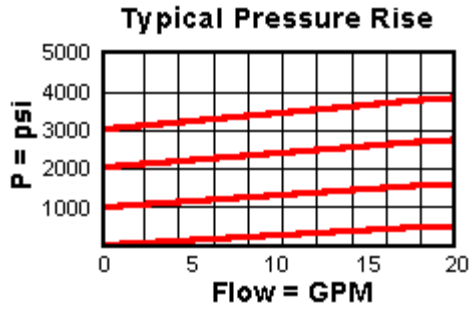

RPCC-KAN

Control	Adjustment Range	External Material/ Seal Material
K Handknob	75 - 3000 psi (5 - 210 A bar), 1000 psi (70 bar) Standard Setting +0.00	N Buna-N +0.00